



Chipsmall Limited consists of a professional team with an average of over 10 year of expertise in the distribution of electronic components. Based in Hongkong, we have already established firm and mutual-benefit business relationships with customers from,Europe,America and south Asia,supplying obsolete and hard-to-find components to meet their specific needs.

With the principle of “Quality Parts,Customers Priority,Honest Operation,and Considerate Service”,our business mainly focus on the distribution of electronic components. Line cards we deal with include Microchip,ALPS,ROHM,Xilinx,Pulse,ON,Everlight and Freescale. Main products comprise IC,Modules,Potentiometer,IC Socket,Relay,Connector.Our parts cover such applications as commercial,industrial, and automotives areas.

We are looking forward to setting up business relationship with you and hope to provide you with the best service and solution. Let us make a better world for our industry!



## Contact us

Tel: +86-755-8981 8866 Fax: +86-755-8427 6832

Email & Skype: info@chipsmall.com Web: www.chipsmall.com

Address: A1208, Overseas Decoration Building, #122 Zhenhua RD., Futian, Shenzhen, China



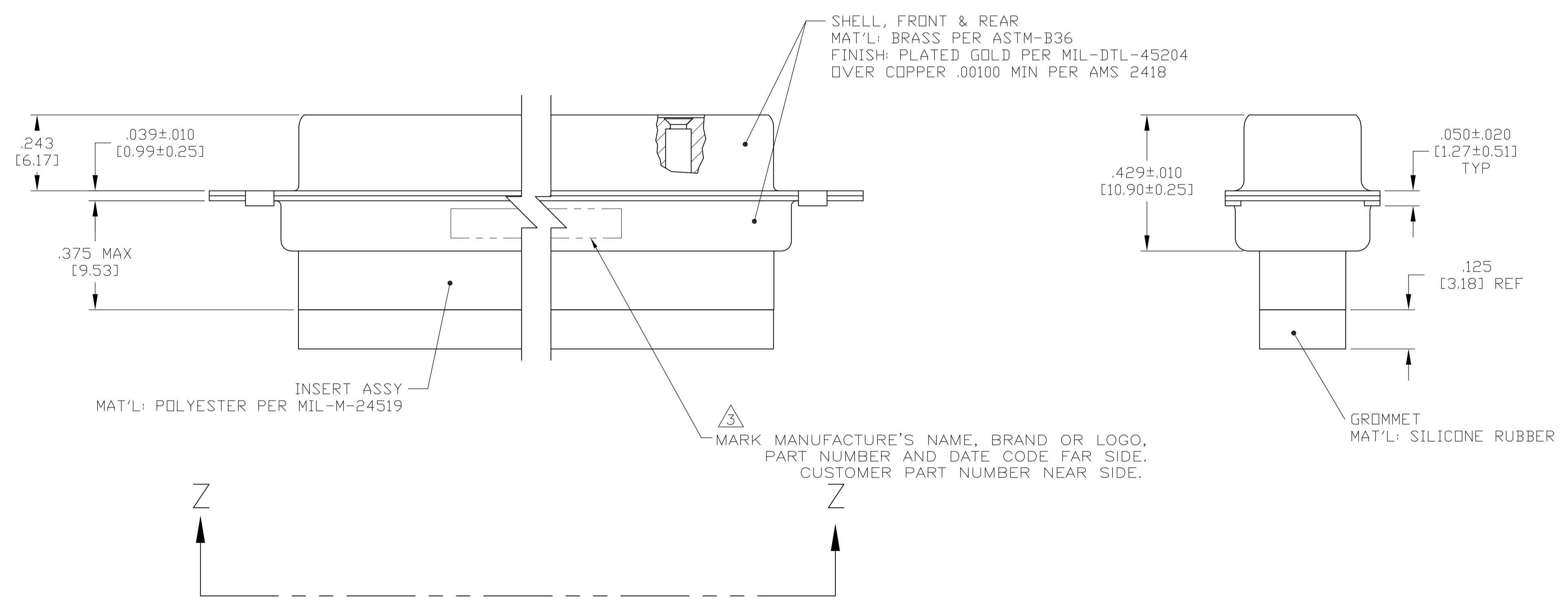
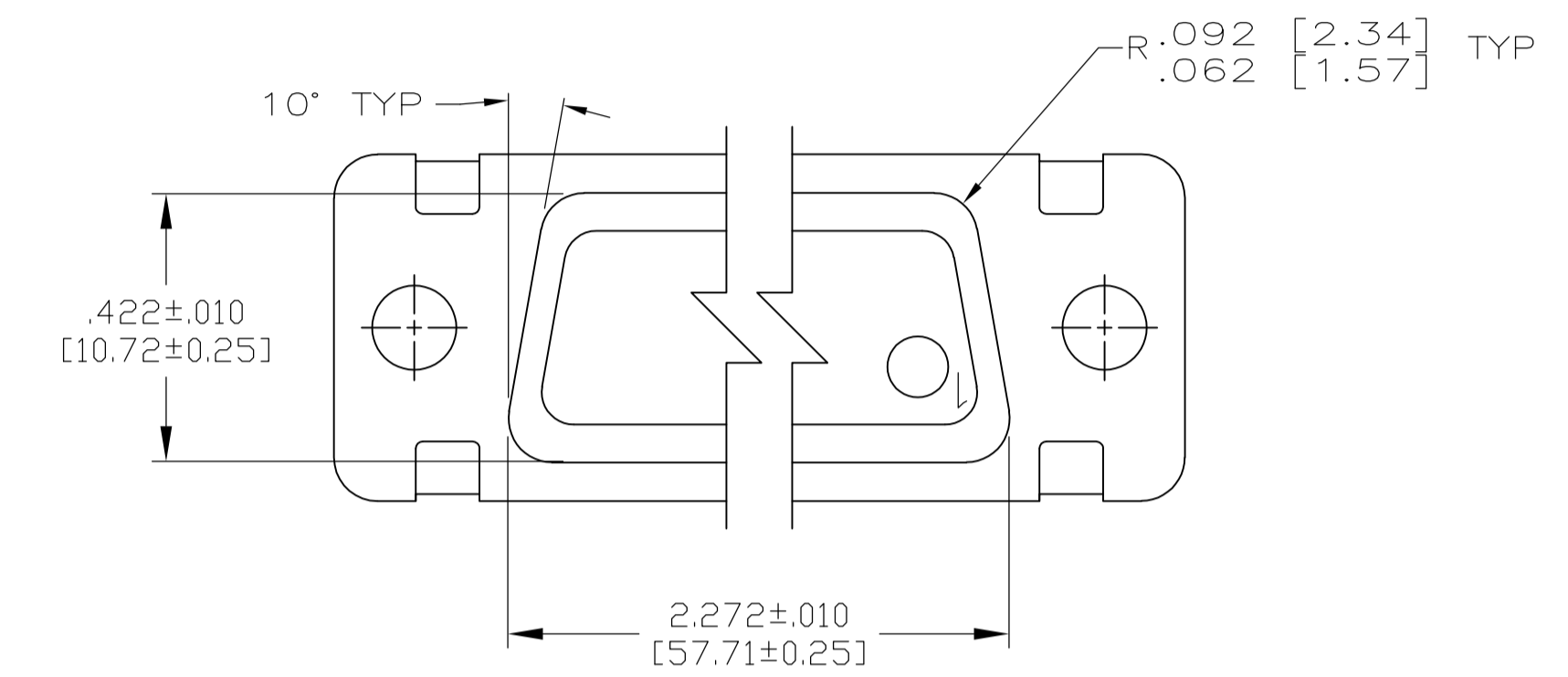
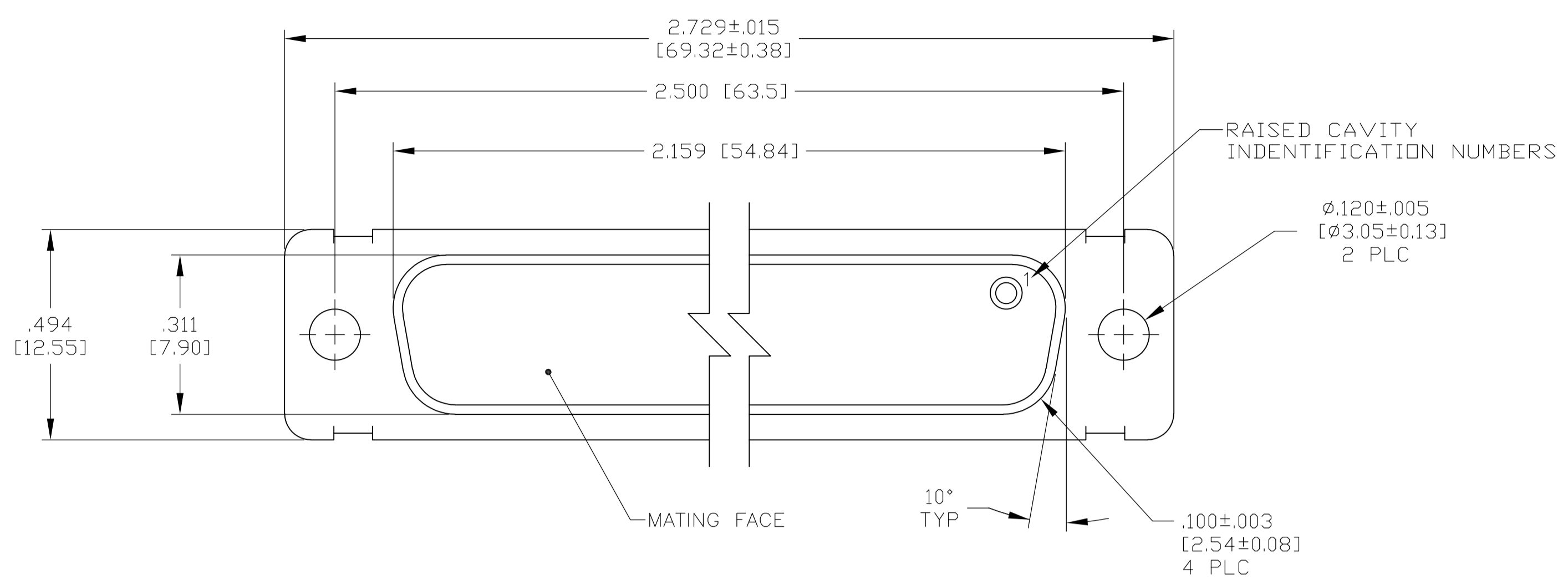

- THIS CONNECTOR ASSEMBLY IS SUPPLIED WITH Be Cu CONTACT RETENTION CLIPS INSTALLED IN THE INSERT ASSEMBLY.
- THIS CONNECTOR ASSEMBLY MATES WITH ANY PLUG CONNECTOR WITH THE SAME INSERT ARRANGEMENT AND DIMENSIONAL REQUIREMENTS PER MIL-C-24308.
- MARKED WITH .047 [1.19]-.062 [1.57] HIGH CHARACTERS. FAR SIDE REFERS TO THE WIDE SIDE OF THE KEYSTONE. NEAR SIDE REFERS TO THE NARROW SIDE OF THE KEYSTONE.
- MAXIMUM WIRE INSULATION TO BE USED WITH THIS CONNECTOR ASSEMBLY IS .068 [1.73] DIAMETER.
- SPECIAL REQUIREMENTS PER BOEING 1A01 DOCUMENT.
- BUILT TO ORDER, NO INVENTORY OF THIS PART NUMBER IS TO BE KEPT. SINGLE LOT DATE CODE REQUIRED.

6 7	1A01-024RHW	1-211636-1
--	---	211636-4
6 7	1A01-024RHA	211636-1
REMARKS	CUSTOMER MARKING	PART NUMBER

THIS DRAWING IS A CONTROLLED DOCUMENT.

DIMENSIONS: INCHES [mm]	TOLERANCES UNLESS OTHERWISE SPECIFIED:	DIN C.C.THOMAS 3-26-07	3-27-07	APPROVED D.MILLER 3-27-07	NAME D.MILLER	PRODUCT SPEC	RECEPTACLE ASSEMBLY, AMPLIMIT, 37 POSITION, SIZE 4, SERIES 109, NON-MAGNETIC
MATERIAL SEE CALLOUTS	FINISH SEE CALLOUTS	WEIGHT	SIZE A1	CAGE CODE 00779	DRAWING NO. 211636	RESTRICTED TO	

CUSTOMER DRAWING SCALE 4:1 SHEET 1 OF 1 REV H