



Chipsmall Limited consists of a professional team with an average of over 10 year of expertise in the distribution of electronic components. Based in Hongkong, we have already established firm and mutual-benefit business relationships with customers from,Europe,America and south Asia,supplying obsolete and hard-to-find components to meet their specific needs.

With the principle of “Quality Parts,Customers Priority,Honest Operation,and Considerate Service”,our business mainly focus on the distribution of electronic components. Line cards we deal with include Microchip,ALPS,ROHM,Xilinx,Pulse,ON,Everlight and Freescale. Main products comprise IC,Modules,Potentiometer,IC Socket,Relay,Connector.Our parts cover such applications as commercial,industrial, and automotives areas.

We are looking forward to setting up business relationship with you and hope to provide you with the best service and solution. Let us make a better world for our industry!



Contact us

Tel: +86-755-8981 8866 Fax: +86-755-8427 6832

Email & Skype: info@chipsmall.com Web: www.chipsmall.com

Address: A1208, Overseas Decoration Building, #122 Zhenhua RD., Futian, Shenzhen, China



1. THIS RECEPTACLE WILL MATE WITH ANY SIZE 5,78 POSN. PLUG IN AMPLIMITE SERIES.
2. CONNECTOR SUPPLIED WITHOUT CONTACTS; SHOWN FOR ILLUSTRATION ONLY.
3. BE-CU RETENTION CLIPS ARE INCLUDED IN INSERTS AND INSTALLED WITH TINES POINTING TOWARDS MATING FACE.
4. OVERALL DIMENSIONS DO NOT INCLUDE RAISED CAVITY IDENTIFICATION
5. MARKING FAR SIDE REFERS TO WIDE SIDE OF KEYSTONE. NEAR SIDE REFERS TO NARROW SIDE OF KEYSTONE.
6. 100% INSPECTION REQUIRED PER BOEING 1B01:
 A. VISUAL
 B. DWV
 C. IR
7. CUSTOMER REQUIRES SINGLE LOT DATE CODE.

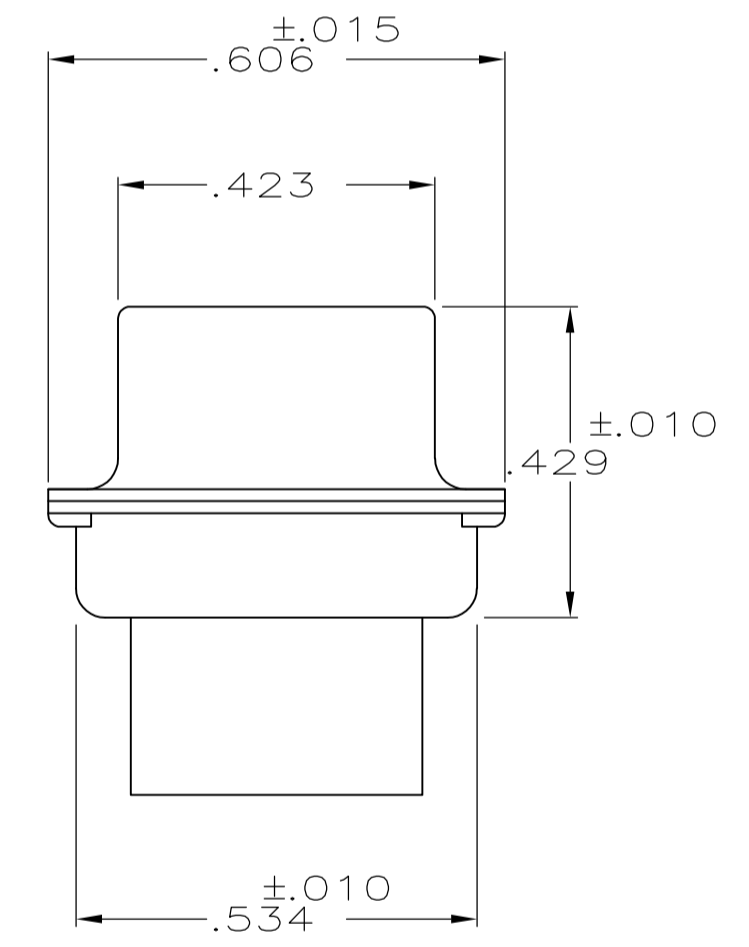
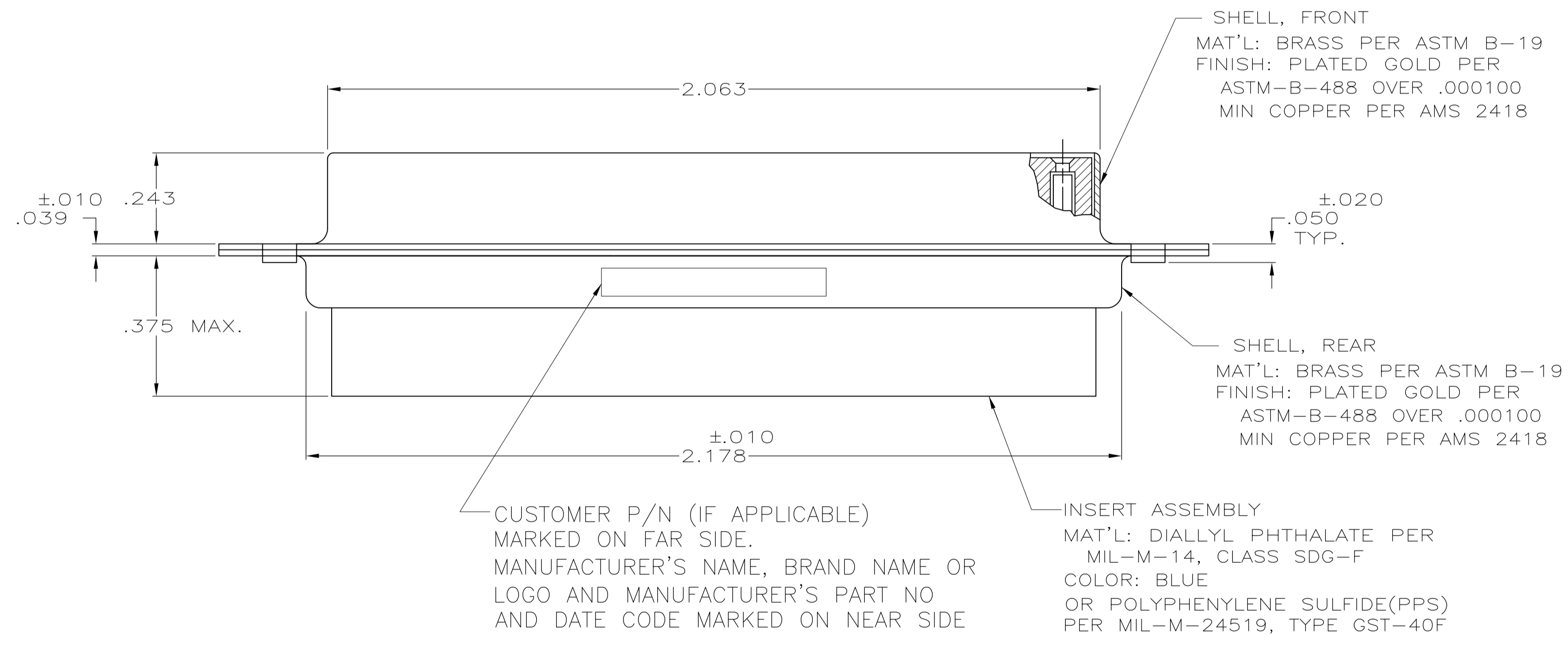
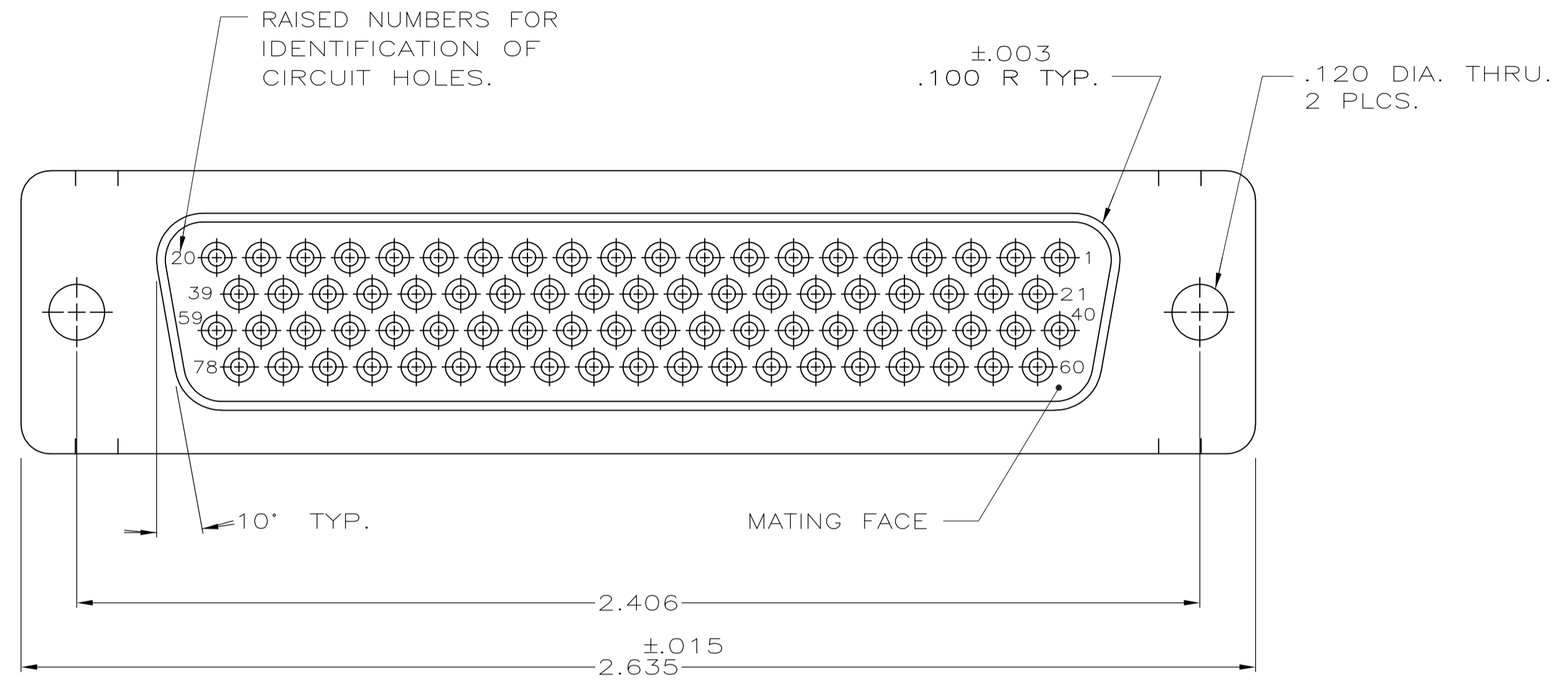

REMARKS	1B01-005RHW	1-211647-1
	1B01-005	211647-1
	CUSTOMER PART NUMBER	PART NO.

THIS DRAWING IS A CONTROLLED DOCUMENT.

DWN D. ERDMAN 16OCT2008	CHK B. YOHN 16OCT2008	AP'D J. BROCHARD 6-29-84	NAME Tyco Electronics Corporation Harrisburg, PA 17105-3608
DIMENSIONS: INCHES		TOLERANCES UNLESS OTHERWISE SPECIFIED:	
0 PLC ± -		1 PLC ± -	
1 PLC ± -		2 PLC ± -	
2 PLC ± -		3 PLC ± .005	
3 PLC ± -		4 PLC ± -	
4 PLC ± -		ANGLES ± 0'30"	
MATERIAL SEE CALLOUT	FINISH SEE CALLOUT	WEIGHT -	RESTRICTED TO -
CUSTOMER DRAWING		SIZE A1	CAGE CODE DRAWING NO 00779
		SCALE NTS	SHEET 1 OF 1
		REV D	

RECEPTACLE ASS'Y, AMPLIMITE
78 POSN, SIZE 5, SERIES 90
NON-MAGNETIC

211647