



Chipsmall Limited consists of a professional team with an average of over 10 year of expertise in the distribution of electronic components. Based in Hongkong, we have already established firm and mutual-benefit business relationships with customers from,Europe,America and south Asia,supplying obsolete and hard-to-find components to meet their specific needs.

With the principle of "Quality Parts,Customers Priority,Honest Operation,and Considerate Service",our business mainly focus on the distribution of electronic components. Line cards we deal with include Microchip,ALPS,ROHM,Xilinx,Pulse,ON,Everlight and Freescale. Main products comprise IC,Modules,Potentiometer,IC Socket,Relay,Connector.Our parts cover such applications as commercial,industrial, and automotives areas.

We are looking forward to setting up business relationship with you and hope to provide you with the best service and solution. Let us make a better world for our industry!



## Contact us

Tel: +86-755-8981 8866 Fax: +86-755-8427 6832

Email & Skype: info@chipsmall.com Web: www.chipsmall.com

Address: A1208, Overseas Decoration Building, #122 Zhenhua RD., Futian, Shenzhen, China



LOC		DIST		REVISIONS			
DF	DO	REV	DATE	DESCRIPTION	DATE	DWN	APVD
C		1	16OCT2008	REV PER ECO 08-022905		PK	BW

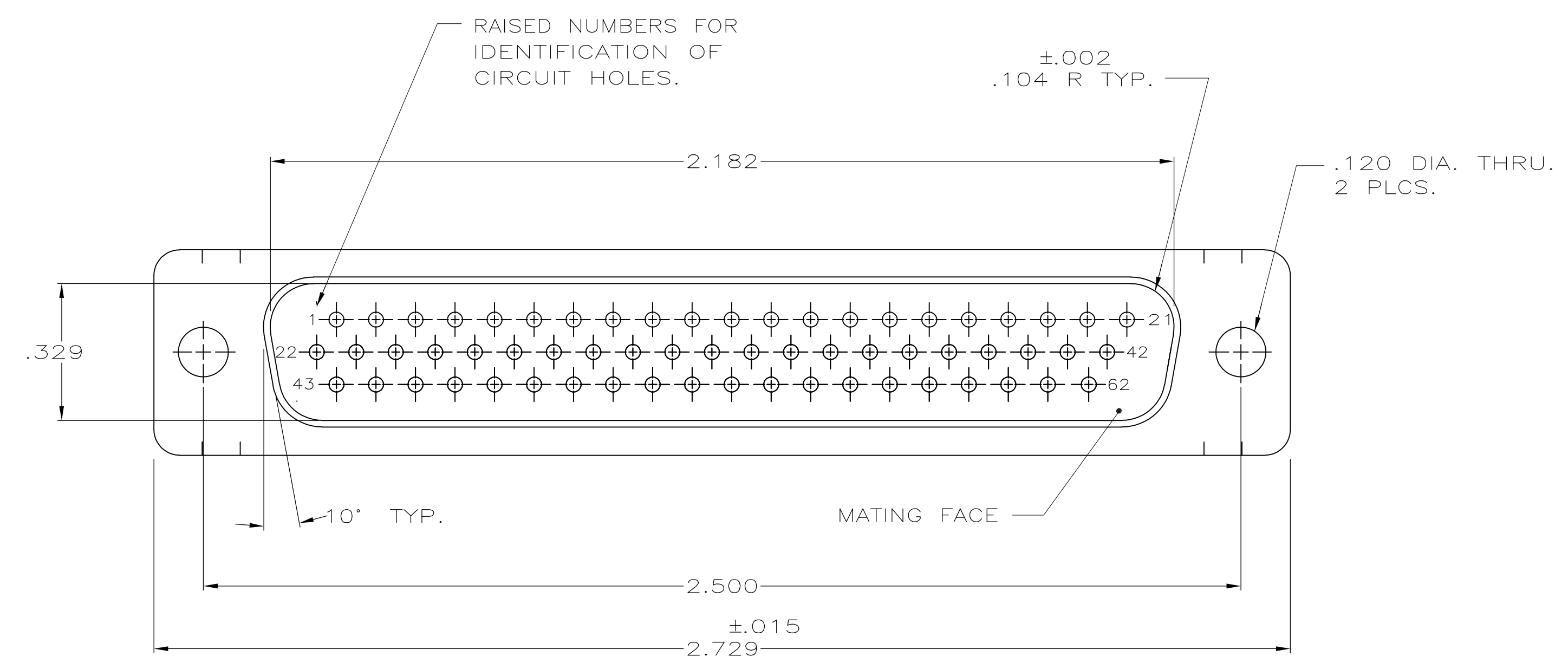

1. THIS PLUG WILL MATE WITH ANY SIZE 4,62 POSN. RECEPTACLE IN AMPLIMITE SERIES.
  2. CONNECTOR SUPPLIED WITHOUT CONTACTS; SHOWN FOR ILLUSTRATION ONLY.
  3. BE-CU RETENTION CLIPS ARE INCLUDED IN INSERTS AND INSTALLED WITH TINES POINTING TOWARDS MATING FACE.
  4. OVERALL DIMENSIONS DO NOT INCLUDE RAISED CAVITY ID.
  5. MARKING FAR SIDE REFERS TO WIDE SIDE OF KEYSTONE. NEAR SIDE REFERS TO NARROW SIDE OF KEYSTONE
- △ 100% INSPECTION REQUIRED PER BOEING 1B01:  
 A. VISUAL  
 B. DWV  
 C. IR
7. CUSTOMER REQUIRES SINGLE LOT DATE CODE.

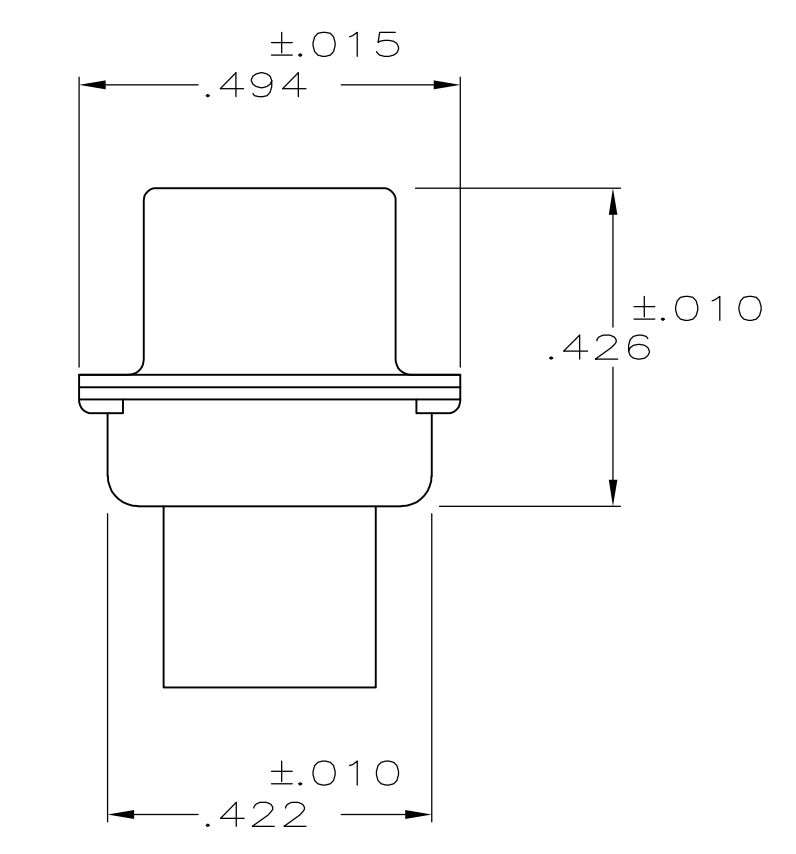
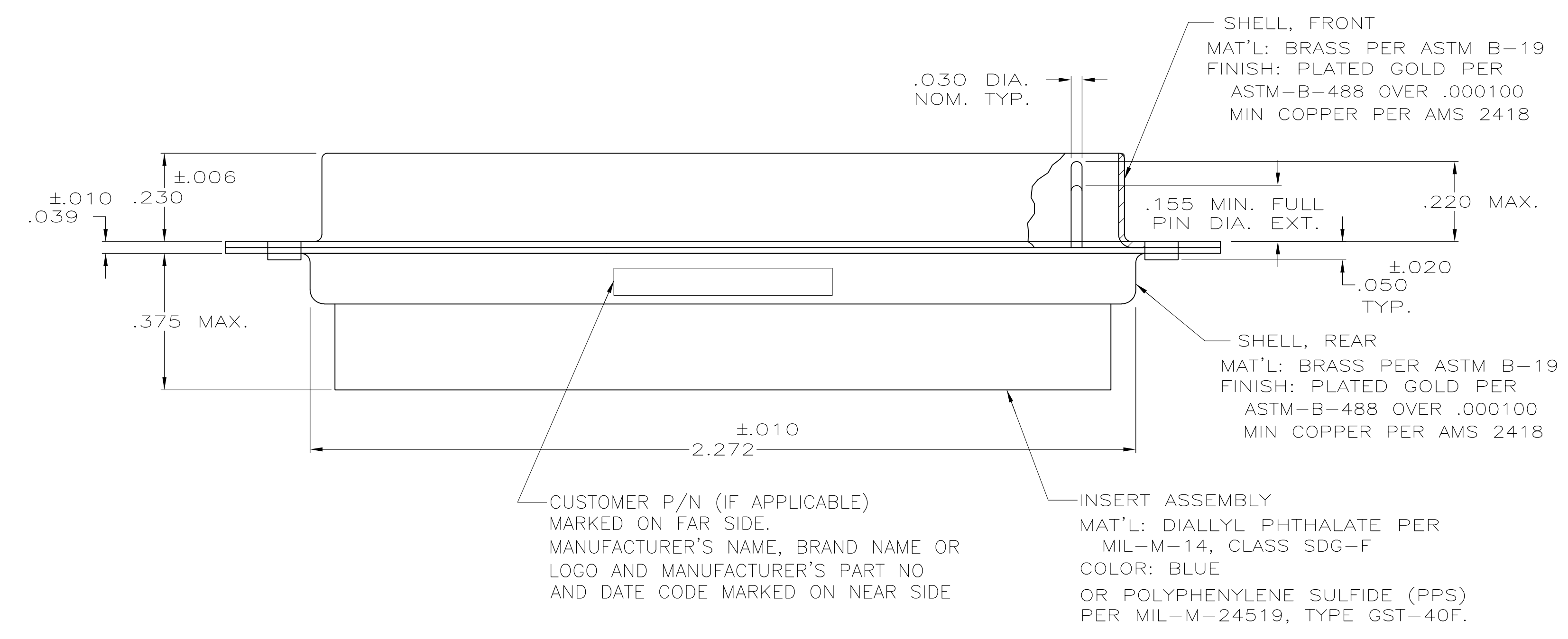

REMARKS	CUSTOMER MARKING	PART NO.
△ 6	1B01 - 010PHW	1-211652-1
△ 6	1B01 - 010	211652-1

THIS DRAWING IS A CONTROLLED DOCUMENT.

DIMENSIONS:	TOLERANCES UNLESS OTHERWISE SPECIFIED:	APPROVED:	DATE:
INCHES:	0 PLC ± -	D. ERDMAN	3-26-84
	1 PLC ± -	B. YOHN	4-26-84
	2 PLC ± -	J. BROSCARD	6-29-84
	3 PLC ± .005		
	4 PLC ± -		
	ANGLES ± 0°30'		

MATERIAL: SEE CALLOUT  
 FINISH: SEE CALLOUT

NAME: Tyco Electronics Corporation  
 Harrisburg, PA 17105-3608

PRODUCT SPEC: PLUG ASS'Y, AMPLIMITE  
 62 POSN, SIZE 4, SERIES 90  
 NON-MAGNETIC

SIZE: A1  
 CAGE CODE: 00779  
 DRAWING NO: 211652

RESTRICTED TO: -

CUSTOMER DRAWING  
 SCALE: NTS  
 SHEET: 1 OF 1  
 REV: C