



Chipsmall Limited consists of a professional team with an average of over 10 year of expertise in the distribution of electronic components. Based in Hongkong, we have already established firm and mutual-benefit business relationships with customers from,Europe,America and south Asia,supplying obsolete and hard-to-find components to meet their specific needs.

With the principle of "Quality Parts,Customers Priority,Honest Operation,and Considerate Service",our business mainly focus on the distribution of electronic components. Line cards we deal with include Microchip,ALPS,ROHM,Xilinx,Pulse,ON,Everlight and Freescale. Main products comprise IC,Modules,Potentiometer,IC Socket,Relay,Connector.Our parts cover such applications as commercial,industrial, and automotives areas.

We are looking forward to setting up business relationship with you and hope to provide you with the best service and solution. Let us make a better world for our industry!



Contact us

Tel: +86-755-8981 8866 Fax: +86-755-8427 6832

Email & Skype: info@chipsmall.com Web: www.chipsmall.com

Address: A1208, Overseas Decoration Building, #122 Zhenhua RD., Futian, Shenzhen, China



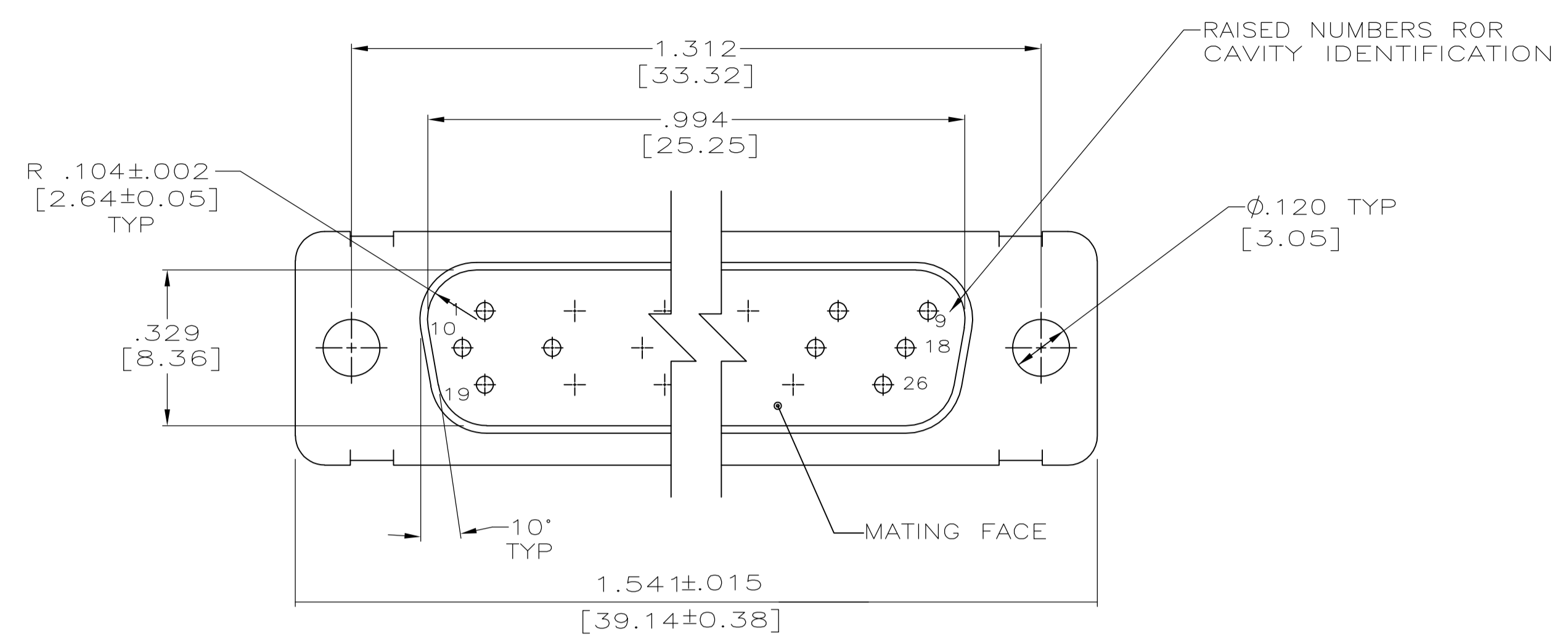

- THIS PLUG WILL MATE WITH ANY SIZE 2, 26 POSN. RCPT. IN AMPLIMITE SERIES.
 - CONNECTOR SUPPLIED WITHOUT CONTACTS; SHOWN FOR ILLUSTRATION ONLY.
 - BE-CU RETENTION CLIPS ARE INCLUDED AND INSTALLED WITH TINES POINTING TOWARDS MATING FACE.
 - ONLY PART NO. 211674-7 IS SUPPLIED WITH CONTACTS.
 - OVERALL DIMENSIONS DO NOT INCLUDE RAISED CAVITY IDENTIFICATION.
 - MARKING ON FAR SIDE REFERS TO WIDE SIDE OF KEYSTONE. NEAR SIDE REFERS TO NARROW SIDE OF KEYSTONE.
- ⚠ 100% INSPECTION REQUIRED PER BOEING 1B01:
 A. VISUAL
 B. DWV
 C. IR
- ⚠ CUSTOMER REQUIRES SINGLE LOT DATE CODE.
- ⚠ SPECIAL REQUIREMENTS:
 A. TEST TWO CONNECTORS PER LOT FOR COMPLIANCE TO GROMMET PEEL STRENGTH REQUIREMENTS.
 B. TEST ALL CIRCUIT CAVITIES FOR MISALIGNMENT OR EXCESSIVE ADHESIVE.

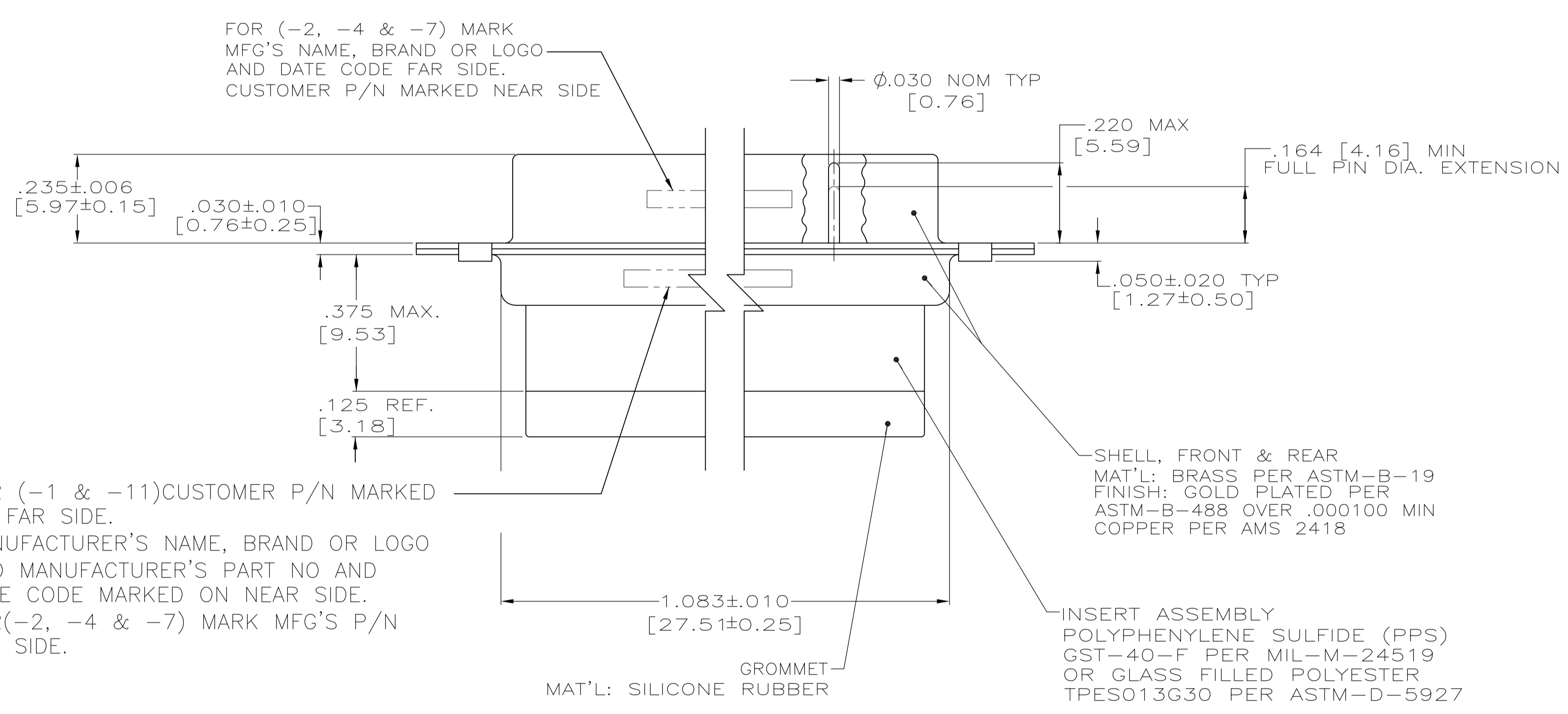

FOR (-2, -4 & -7) MARK MFG'S NAME, BRAND OR LOGO AND DATE CODE FAR SIDE. CUSTOMER P/N MARKED NEAR SIDE.

FOR (-1 & -11) CUSTOMER P/N MARKED ON FAR SIDE. MANUFACTURER'S NAME, BRAND OR LOGO AND MANUFACTURER'S PART NO AND DATE CODE MARKED ON NEAR SIDE. FOR (-2, -4 & -7) MARK MFG'S P/N FAR SIDE.

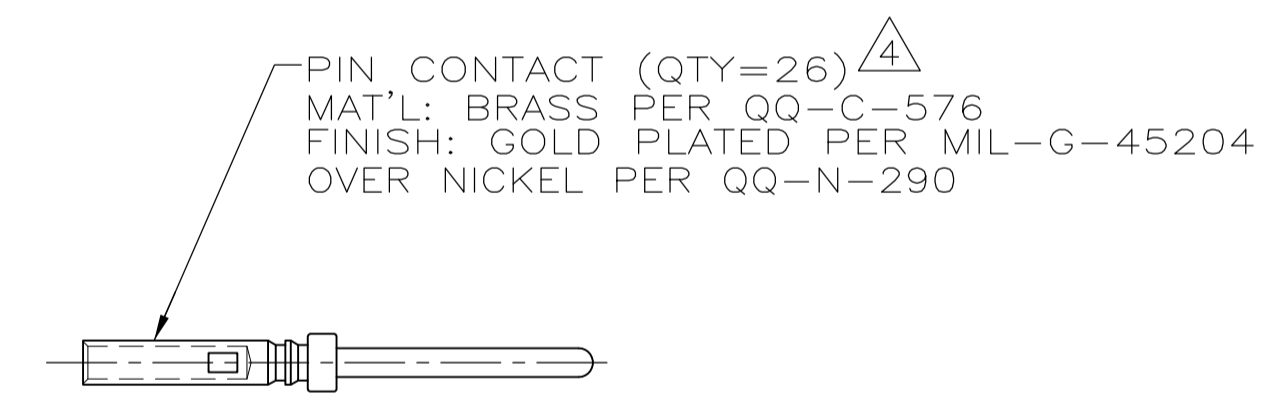
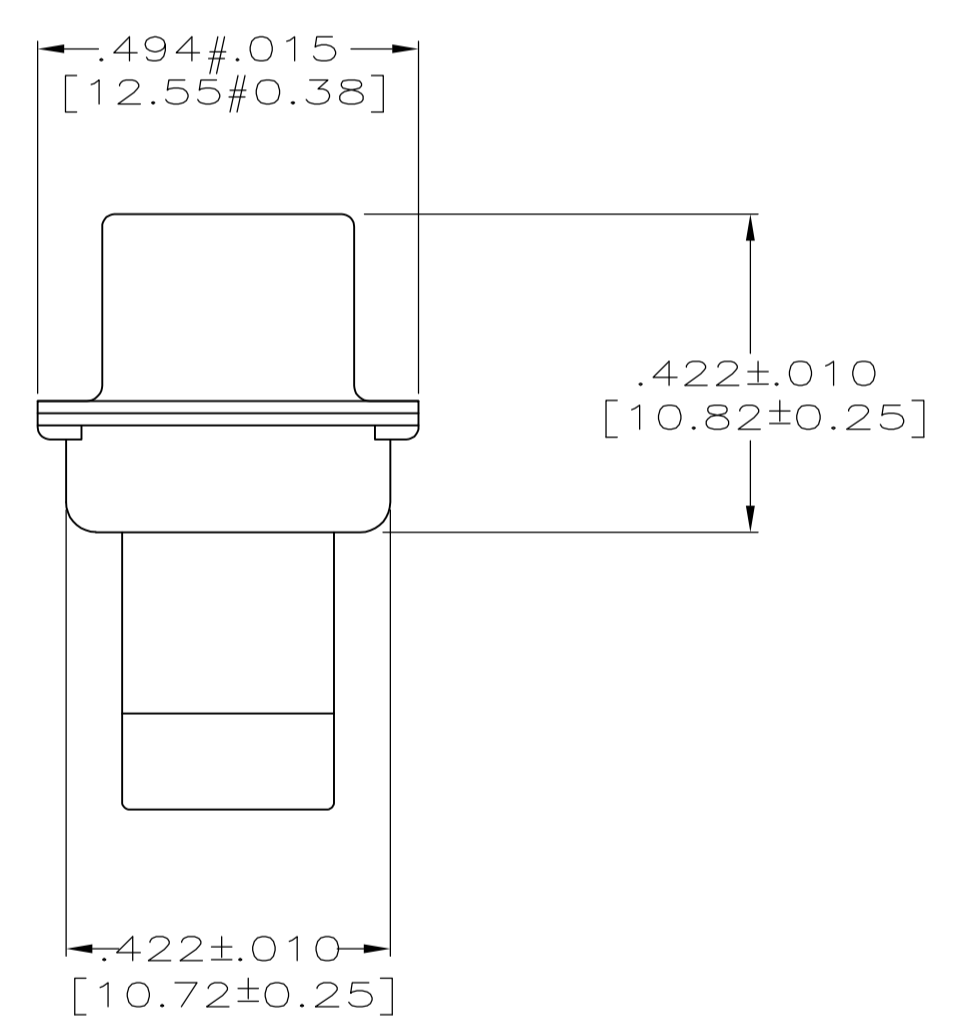

| | | |
|---------|-------------------|------------|
| ⚠ | 1B01-032PHW | 1-211674-1 |
| ⚠ | B010648-0003 | 211674-7 |
| | | 211674-4 |
| ⚠ | 2A065-014V-001 | 211674-2 |
| ⚠ | 1B01-032 | 211674-1 |
| REMARKS | CUSTOMER PART NO. | PART NO. |

THIS DRAWING IS A CONTROLLED DOCUMENT.

| | | | | | | | |
|-------------------------|--|-----------|-----------|-----------|---------------------|---------------|------------|
| DIMENSIONS: INCHES [mm] | TOLERANCES UNLESS OTHERWISE SPECIFIED: | 0 PLC ± - | 1 PLC ± - | 2 PLC ± - | 3 PLC ± .005 [0.13] | 4 PLC ± - | ANGLES ± - |
| MATERIAL SEE CALLOUTS | FINISH SEE CALLOUTS | WEIGHT | SIZE | CAGE CODE | DRAWING NO. | RESTRICTED TO | |
| | | | A1 | 00779 | 211674 | | |

CUSTOMER DRAWING SCALE 4:1 SHEET 1 OF 1 REV M