



Chipsmall Limited consists of a professional team with an average of over 10 year of expertise in the distribution of electronic components. Based in Hongkong, we have already established firm and mutual-benefit business relationships with customers from,Europe,America and south Asia,supplying obsolete and hard-to-find components to meet their specific needs.

With the principle of “Quality Parts,Customers Priority,Honest Operation,and Considerate Service”,our business mainly focus on the distribution of electronic components. Line cards we deal with include Microchip,ALPS,ROHM,Xilinx,Pulse,ON,Everlight and Freescale. Main products comprise IC,Modules,Potentiometer,IC Socket,Relay,Connector.Our parts cover such applications as commercial,industrial, and automotives areas.

We are looking forward to setting up business relationship with you and hope to provide you with the best service and solution. Let us make a better world for our industry!



## Contact us

Tel: +86-755-8981 8866 Fax: +86-755-8427 6832

Email & Skype: info@chipsmall.com Web: www.chipsmall.com

Address: A1208, Overseas Decoration Building, #122 Zhenhua RD., Futian, Shenzhen, China



THIS DRAWING IS UNPUBLISHED. RELEASED FOR PUBLICATION 20  
 © COPYRIGHT 20 BY TYCO ELECTRONICS CORPORATION ALL RIGHTS RESERVED.

LOC	DIST	REVISIONS			
P	LTR	DESCRIPTION	DATE	DWN	APVD
00	AJ	A	RELEASED.	16SEP2014	KF PG
		AI	UPDATE CONNECTOR NOTE	15DEC2015	JPS JLM
		B	REVISED PER ECO-16-018604	28DEC2016	AP JM
		CI	REMOVE MCIS NOTE, ADD COAX INFO IN BOM	07MAR2017	JPS JLM

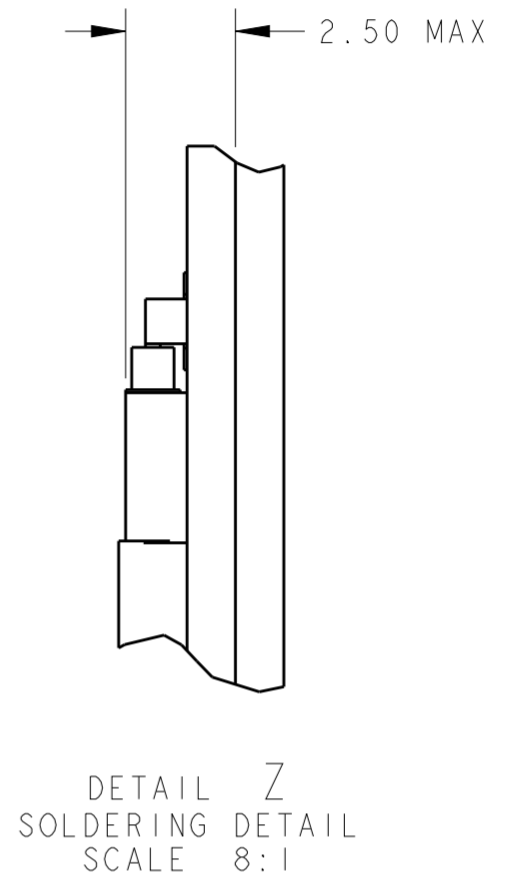
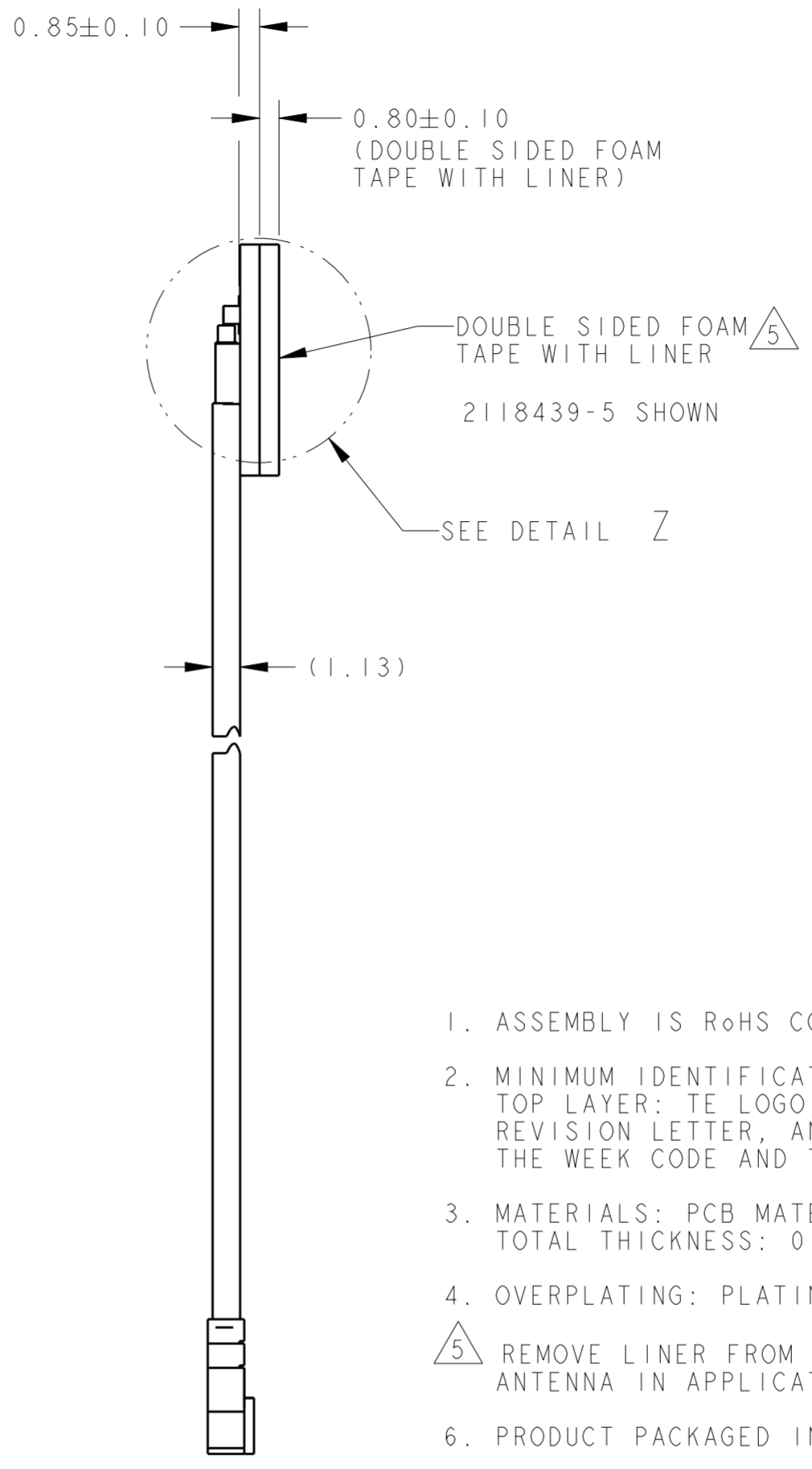
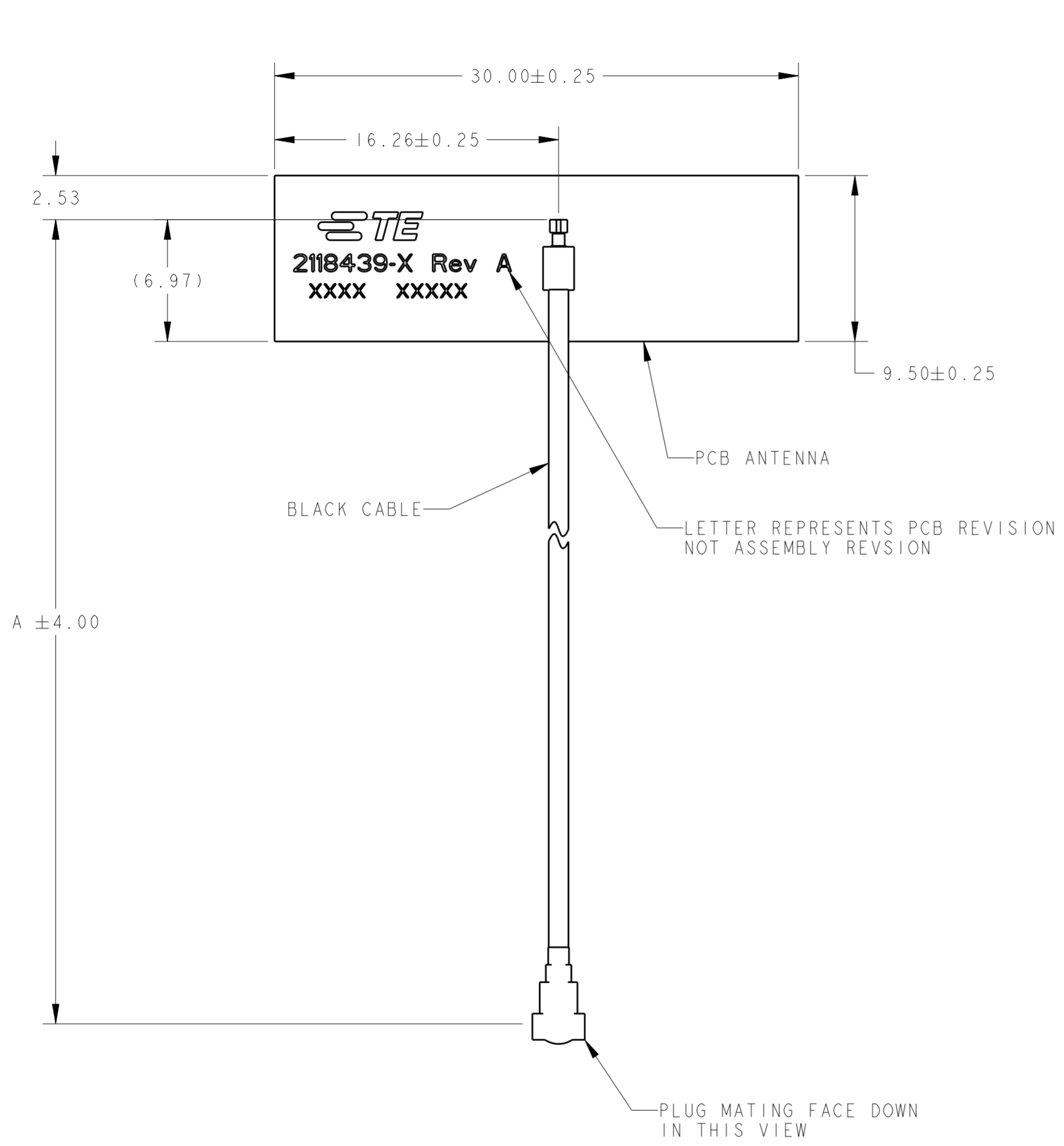

- ASSEMBLY IS RoHS COMPLIANT.
- MINIMUM IDENTIFICATION INCLUDES:  
TOP LAYER: TE LOGO, TE ASSEMBLY BASE PART NUMBER, ASSEMBLY REVISION LETTER, AND FOUR DIGIT DATE CODE (FIRST 2 DIGITS FOR THE WEEK CODE AND THE 2ND TWO DIGITS FOR THE YEAR CODE).
- MATERIALS: PCB MATERIAL  
TOTAL THICKNESS: 0.85 SINGLE SIDE, 1/2 OUNCE COPPER.
- OVERPLATING: PLATING ON EXPOSED COPPER AREAS TO BE E.N.I.G. FINISH.
- REMOVE LINER FROM DOUBLE SIDED FOAM TAPE 3M VHB 5608 TO APPLY ANTENNA IN APPLICATION.
- PRODUCT PACKAGED IN A BAG.

I-PEX	200.00	N	2118439-7
ECT	100.00	N	2118439-6
ECT	150.00	Y $\triangle$ 5	2118439-5
ECT	300.00	N	2118439-4
ECT	160.00	N	2118439-3
ECT	310.00	N	2118439-2
ECT	250.00	N	2118439-1
COAX MFG	A	DOUBLE SIDED FOAM TAPE APPLIES	PART NUMBER

**CONFIDENTIAL**

THIS INFORMATION IS CONFIDENTIAL AND IS DISCLOSED TO YOU ON CONDITION THAT NO FURTHER DISCLOSURE IS MADE BY YOU TO OTHER THAN TYCO ELECTRONICS PERSONNEL WITHOUT WRITTEN AUTHORIZATION FROM TYCO ELECTRONICS, HARRISBURG, PA.

THIS DRAWING IS A CONTROLLED DOCUMENT.		DWN K. FOLTZ 18MAR2014	TE Connectivity	
DIMENSIONS: mm		CHK J. MOORE 18MAR2014		
TOLERANCES UNLESS OTHERWISE SPECIFIED:		APVD J. MOORE 18MAR2014		
0 PLC ± 1 PLC ± 2 PLC ± 3 PLC ± 4 PLC ± ANGLES ± FINISH		PRODUCT SPEC APPLICATION SPEC WEIGHT		
MATERIAL		NAME PCB ANTENNA ASSEMBLY, WITH MHF CONNECTOR		RESTRICTED TO
SEE NOTES		SIZE A200779		SCALE 4:1
SEE NOTES		DRAWING NO C-2118439		SHEET OF
CUSTOMER DRAWING		SCALE 4:1		REV C1