



Chipsmall Limited consists of a professional team with an average of over 10 year of expertise in the distribution of electronic components. Based in Hongkong, we have already established firm and mutual-benefit business relationships with customers from,Europe,America and south Asia,supplying obsolete and hard-to-find components to meet their specific needs.

With the principle of "Quality Parts,Customers Priority,Honest Operation,and Considerate Service",our business mainly focus on the distribution of electronic components. Line cards we deal with include Microchip,ALPS,ROHM,Xilinx,Pulse,ON,Everlight and Freescale. Main products comprise IC,Modules,Potentiometer,IC Socket,Relay,Connector.Our parts cover such applications as commercial,industrial, and automotives areas.

We are looking forward to setting up business relationship with you and hope to provide you with the best service and solution. Let us make a better world for our industry!



Contact us

Tel: +86-755-8981 8866 Fax: +86-755-8427 6832

Email & Skype: info@chipsmall.com Web: www.chipsmall.com

Address: A1208, Overseas Decoration Building, #122 Zhenhua RD., Futian, Shenzhen, China



C2	NOTES ADDED	01JUL2011	KHH	HEIN
D1	DETAILS SEE PCN E-13-000131	05JAN2013	SJ	HR
D2	DETAILS SEE PCN E-13-000142	15JAN2013	ER	RH
E1	WEB REWORKED PER PCN E-13-012625	08AUG2013	ER	DO

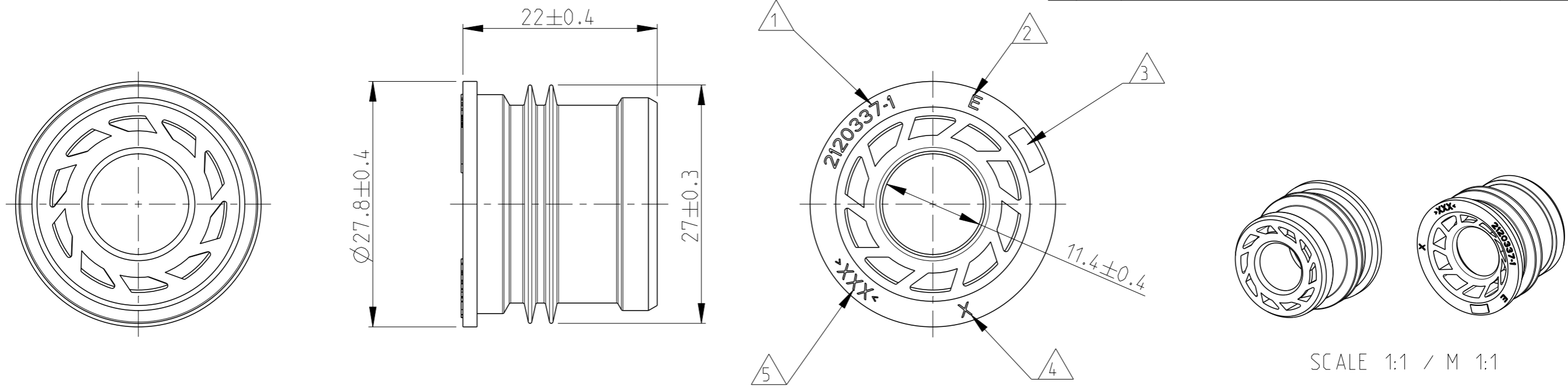

- 1 PARTNUMBER
- 2 REVISION STATUS
- 3 DATE WW/YY
- 4 CAVITY IDENTIFIER
- 5 MATERIAL IDENTIFIER
- 6 PACKAGING: PARTS IN PE-BAG BULK PACKED INTO FOLDING BOX

-1 AS SHOWN
WIE GEZEICHNET

- 1 SACHNUMMER
- 2 REVISIONSSTAND
- 3 DATUM WW/JJ
- 4 NESTKENNZEICHNUNG
- 5 MATERIALKENNZEICHNUNG
- 6 VERPACKUNG: TEILE ALS SCHUETTUT IN PE-BAG IN EINEM KARTON VERPACKT

Ø13-Ø16.7	BLACK	TPV (EPDM+PP)	5.21	CABLE SEAL KABELDICHTUNG	2120337-1									
WIRE DIAMETER [MM] KABELDURCHMESSER [mm]	SURFACE/COLOUR Oberflaeche/Farbe	MATERIAL	WEIGHT (g)	DESCRIPTION BENENNUNG	PART-NO. TEILE-Nr.									
THIS DRAWING IS A CONTROLLED DOCUMENT. DIESES ZEICHNUNGSdokUMENT WIRD DURCH AMP INCORPORATED KONTROLLIERT. ÄNDERUNGEN, DIE DEM TECHNISCHEN FORTSCHRITT DIENEN, SIND VORBEHALTEN. DEN JEWEILS LETZTGEÜLTIGEN ÄNDERUNGSSTAND ERFAHREN SIE AUF ANFRAGE.		DWN S. HASS 30SEP2010	TE Connectivity CABLE SEAL KABELDICHTUNG MOTORMAN HYBRID CONNECTOR											
DIMENSIONS: MASSEINHEITEN: [mm]		CHK K.-H. HESS 30SEP2010												
TOLERANCES UNLESS OTHERWISE SPECIFIED: ALLGEMEINTOLERANZEN		APVD S. HEIN 30SEP2010												
<table border="1"> <tr><td>0 PLC</td><td>±0.25</td></tr> <tr><td>1 PLC</td><td>±0.2</td></tr> <tr><td>2 PLC</td><td>±0.1</td></tr> <tr><td>3 PLC</td><td>±</td></tr> <tr><td>4 PLC</td><td>±</td></tr> <tr><td>ANGLES/WINKEL</td><td>±2°</td></tr> </table>		0 PLC				±0.25	1 PLC	±0.2	2 PLC	±0.1	3 PLC	±	4 PLC	±
0 PLC	±0.25													
1 PLC	±0.2													
2 PLC	±0.1													
3 PLC	±													
4 PLC	±													
ANGLES/WINKEL	±2°													
MATERIAL	FINISH/OBERFLAECHEN/FARBE	APPLICATION SPEC VERARBEITUNGSSPEZ. 114-91067	SIZE A3	CAGE CODE 00779	DRAWING NO. ZEICHNUNGS-NR. G=2120337									
		WEIGHT GEWICHT	RESTRICTED TO NUR FUER											
		Customer Drawing	/KUNDENZEICHNUNG	SCALE MASSSTAB 2:1	SHEET BLATT 1 OF VON 1									
				REV E1										