



Chipsmall Limited consists of a professional team with an average of over 10 year of expertise in the distribution of electronic components. Based in Hongkong, we have already established firm and mutual-benefit business relationships with customers from,Europe,America and south Asia,supplying obsolete and hard-to-find components to meet their specific needs.

With the principle of "Quality Parts,Customers Priority,Honest Operation,and Considerate Service",our business mainly focus on the distribution of electronic components. Line cards we deal with include Microchip,ALPS,ROHM,Xilinx,Pulse,ON,Everlight and Freescale. Main products comprise IC,Modules,Potentiometer,IC Socket,Relay,Connector.Our parts cover such applications as commercial,industrial, and automotives areas.

We are looking forward to setting up business relationship with you and hope to provide you with the best service and solution. Let us make a better world for our industry!



## Contact us

Tel: +86-755-8981 8866 Fax: +86-755-8427 6832

Email & Skype: info@chipsmall.com Web: www.chipsmall.com

Address: A1208, Overseas Decoration Building, #122 Zhenhua RD., Futian, Shenzhen, China



REVISONS		DATE	BY	APPV
NO	DESCRIPTION			
N	REV PER ECO 13-001184	1-29-13	RL	CT

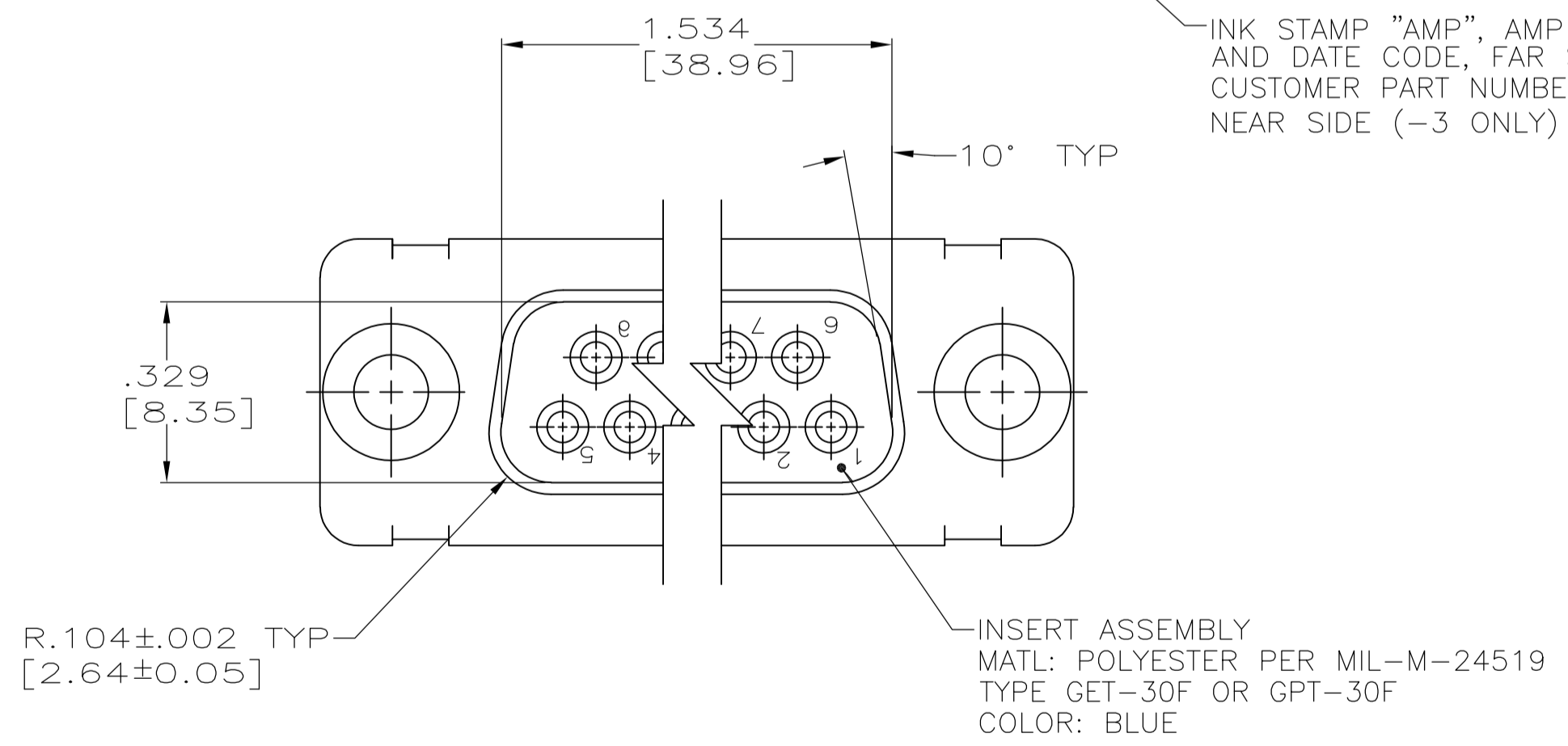
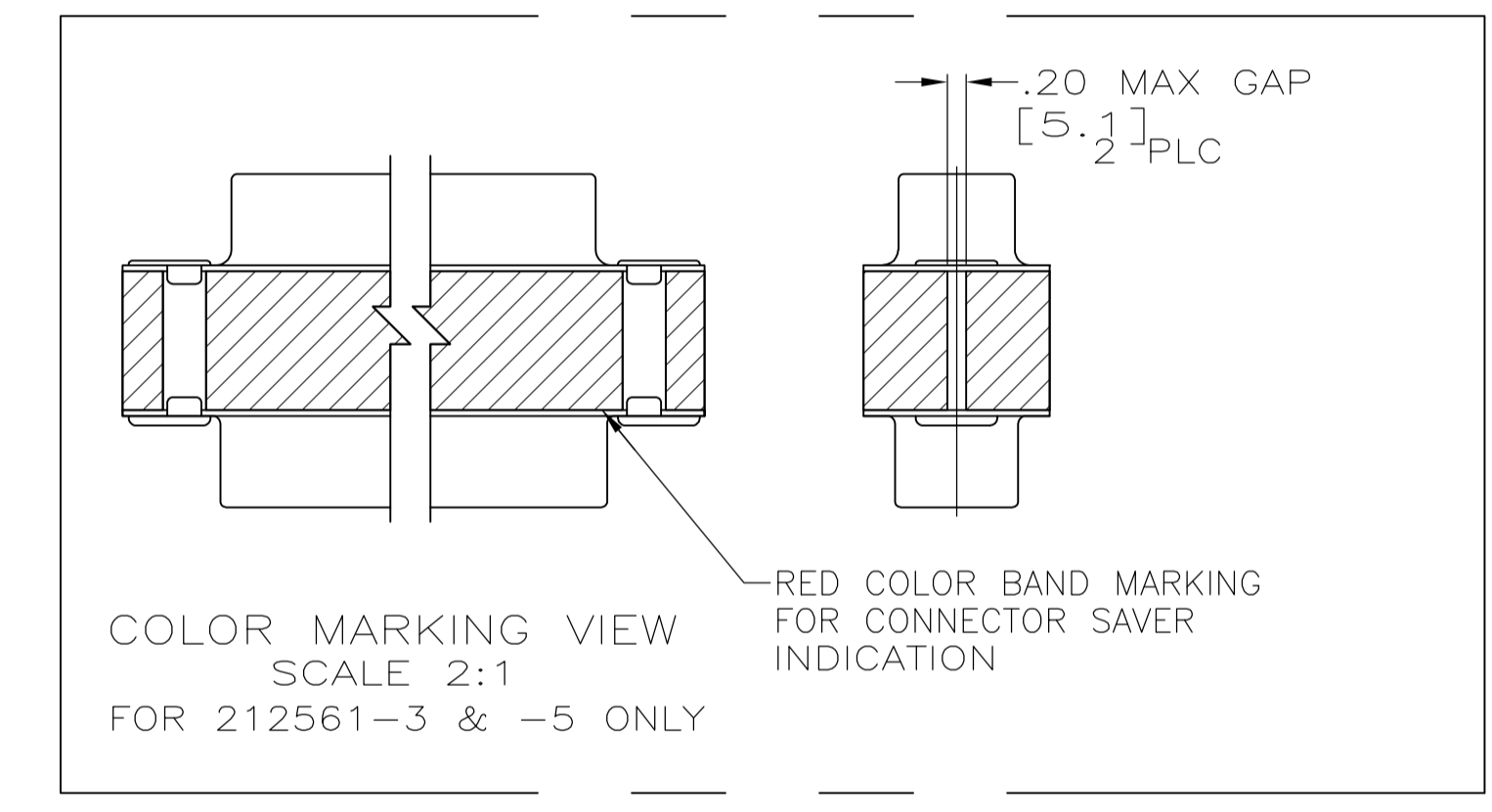
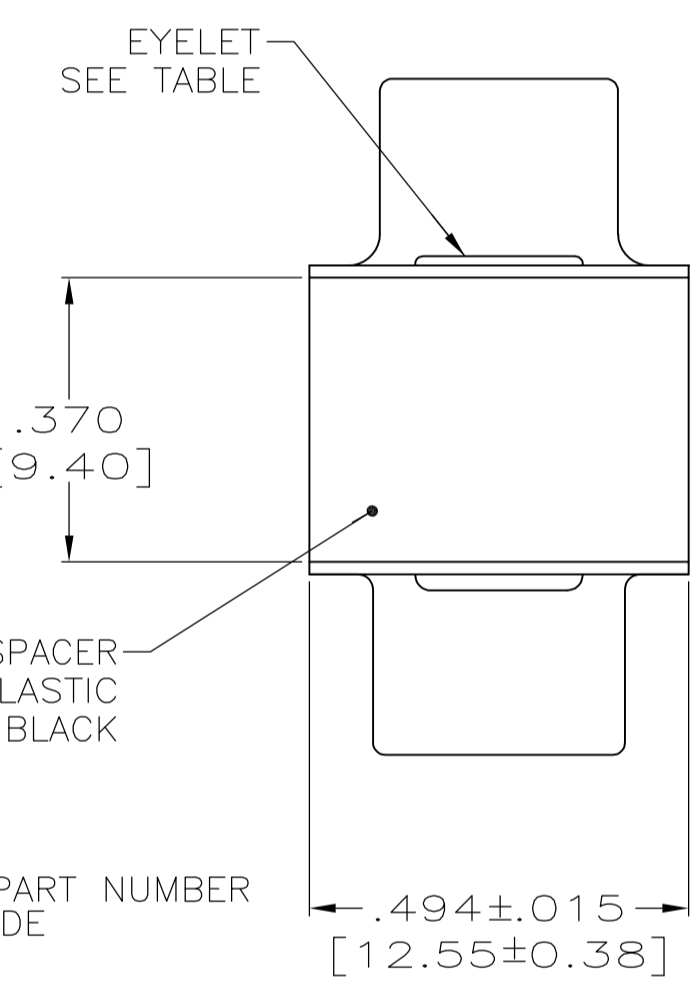
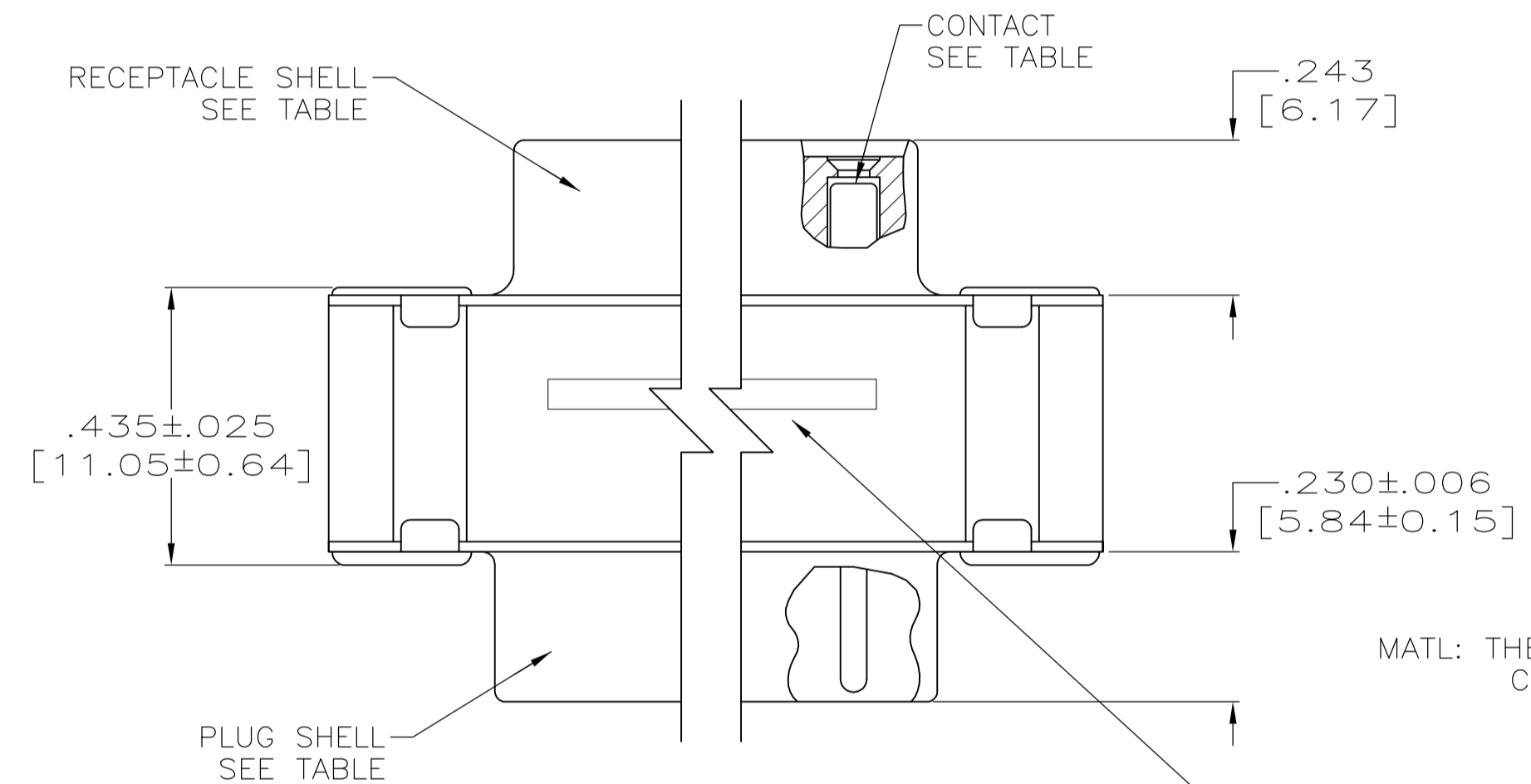
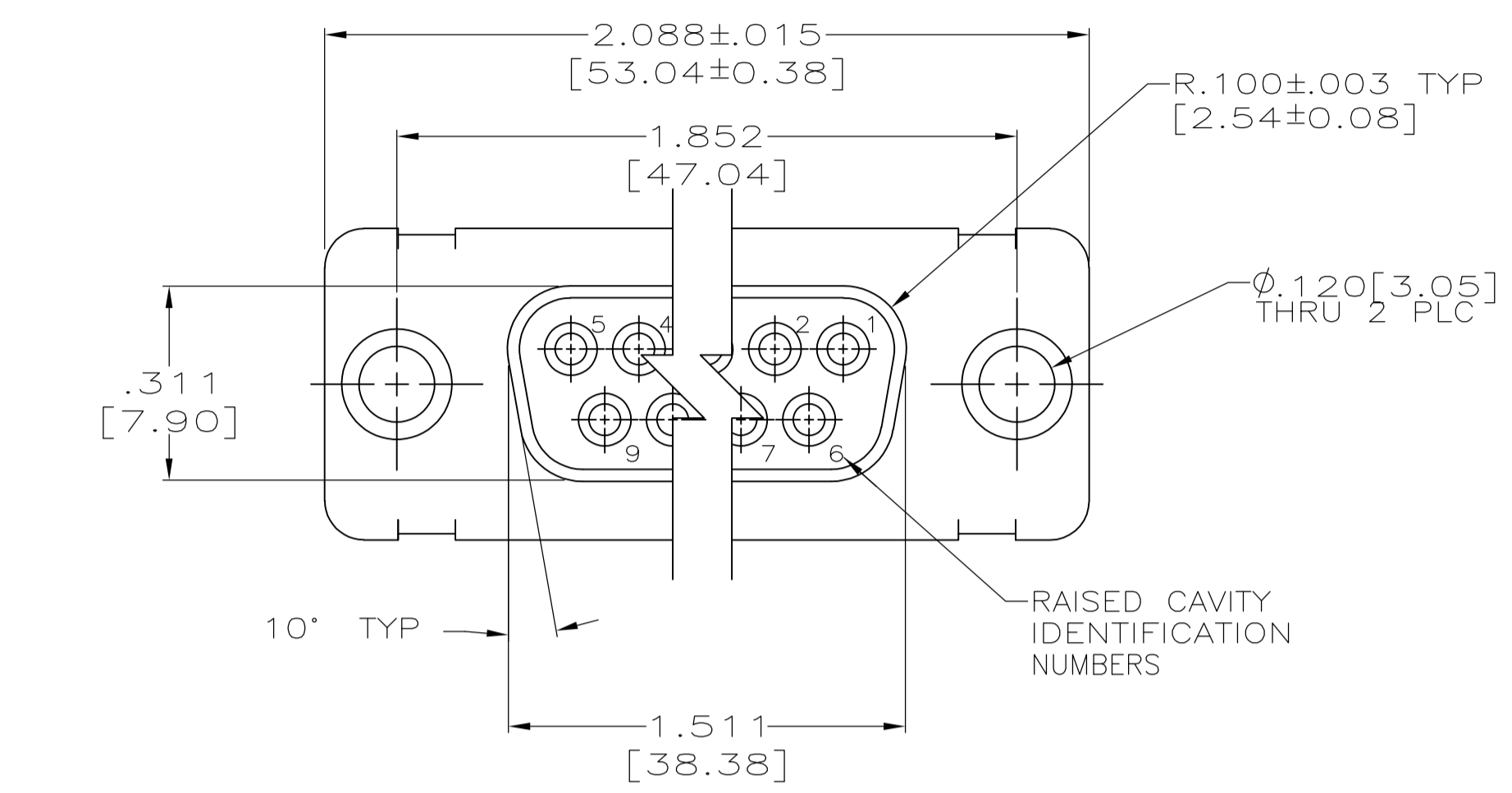

- CONTACTS INCLUDED IN ASSEMBLY.
- MATL: STEEL, PER ASTM-A-109.
- FINISH: CADIUM PER QQ-P-416.
- CONTACT  
 BODY MATL: BERYLLIUM COPPER PER ASTM-B-197.  
 BODY FINISH: PLATED GOLD, .000050 MIN THK PER MIL-G-45204 OVER NICKEL, .000050 MIN THK PER QQ-N-290.  
 HOOD MATL: STAINLESS STEEL PER ASTM-A-167.  
 HOOD FINISH: PASSIVATED PER ASTM-A-380.
- FINISH: PLATED ZINC .00020 MIN THK PER ASTM-B-633. YELLOW CHROMATE FINISH.
- MATL: BRASS PER ASTM-B-36.
- FINISH: PLATED GOLD, .000050 MIN THK PER MIL-G-45204 OVER COPPER, .000100 MIN THK PER MIL-C-14550.
- CONTACT  
 BODY MATL: BERYLLIUM COPPER PER ASTM-B-197.  
 BODY AND HOOD FINISH: PLATED GOLD, .000050 MIN THK PER MIL-G-45204 OVER COPPER, .000100 MIN THK PER MIL-C-14550.  
 HOOD MATL: BRASS PER ASTM-B-36
- FINISH: PLATED ZINC PER ASTM-B-633 .000200 MIN THK WITH SUPPLEMENTARY CHROMATE (Cr3+).

				5-212561-1
			4U884 SOCN R10002677-0103	212561-5
OBSOLETE				212561-4
			(1J02-103)	212561-3
				212561-2
				212561-1
EYELET	SHELLS	CONTACT	CUSTOMER P/N	PART NO.

THIS DRAWING IS A CONTROLLED DOCUMENT.		DIN T. THOMPSON 11-07-94																					
DIMENSIONS: INCHES		TOLERANCES UNLESS OTHERWISE SPECIFIED:																					
<table border="1"> <tr><td>0 PLC</td><td>± .005</td></tr> <tr><td>1 PLC</td><td>± .005</td></tr> <tr><td>2 PLC</td><td>± .005</td></tr> <tr><td>3 PLC</td><td>± .005 [0.13]</td></tr> <tr><td>4 PLC</td><td>± .005</td></tr> <tr><td>ANGLES</td><td>± .005</td></tr> </table>		0 PLC	± .005	1 PLC	± .005	2 PLC	± .005	3 PLC	± .005 [0.13]	4 PLC	± .005	ANGLES	± .005	<table border="1"> <tr><td>APPROV</td><td>D. MANTIONE</td></tr> <tr><td>PRODUCT SPEC</td><td></td></tr> <tr><td>APPLICATION SPEC</td><td></td></tr> <tr><td>WEIGHT</td><td></td></tr> </table>		APPROV	D. MANTIONE	PRODUCT SPEC		APPLICATION SPEC		WEIGHT	
0 PLC	± .005																						
1 PLC	± .005																						
2 PLC	± .005																						
3 PLC	± .005 [0.13]																						
4 PLC	± .005																						
ANGLES	± .005																						
APPROV	D. MANTIONE																						
PRODUCT SPEC																							
APPLICATION SPEC																							
WEIGHT																							
MATERIAL: -		FINISH: -																					
CUSTOMER DRAWING		SCALE 4:1 SHEET 1 OF 1 REV N																					