



Chipsmall Limited consists of a professional team with an average of over 10 year of expertise in the distribution of electronic components. Based in Hongkong, we have already established firm and mutual-benefit business relationships with customers from,Europe,America and south Asia,supplying obsolete and hard-to-find components to meet their specific needs.

With the principle of “Quality Parts,Customers Priority,Honest Operation,and Considerate Service”,our business mainly focus on the distribution of electronic components. Line cards we deal with include Microchip,ALPS,ROHM,Xilinx,Pulse,ON,Everlight and Freescale. Main products comprise IC,Modules,Potentiometer,IC Socket,Relay,Connector.Our parts cover such applications as commercial,industrial, and automotives areas.

We are looking forward to setting up business relationship with you and hope to provide you with the best service and solution. Let us make a better world for our industry!



## Contact us

Tel: +86-755-8981 8866 Fax: +86-755-8427 6832

Email & Skype: info@chipsmall.com Web: www.chipsmall.com

Address: A1208, Overseas Decoration Building, #122 Zhenhua RD., Futian, Shenzhen, China



| LOC |     | DIST                     |         | REVISIONS |      |  |  |
|-----|-----|--------------------------|---------|-----------|------|--|--|
| P   | LTR | DESCRIPTION              | DATE    | DWN       | APVD |  |  |
| L   |     | REVISED PER 063B-0127-05 | 4/13/05 | SS        | GS   |  |  |

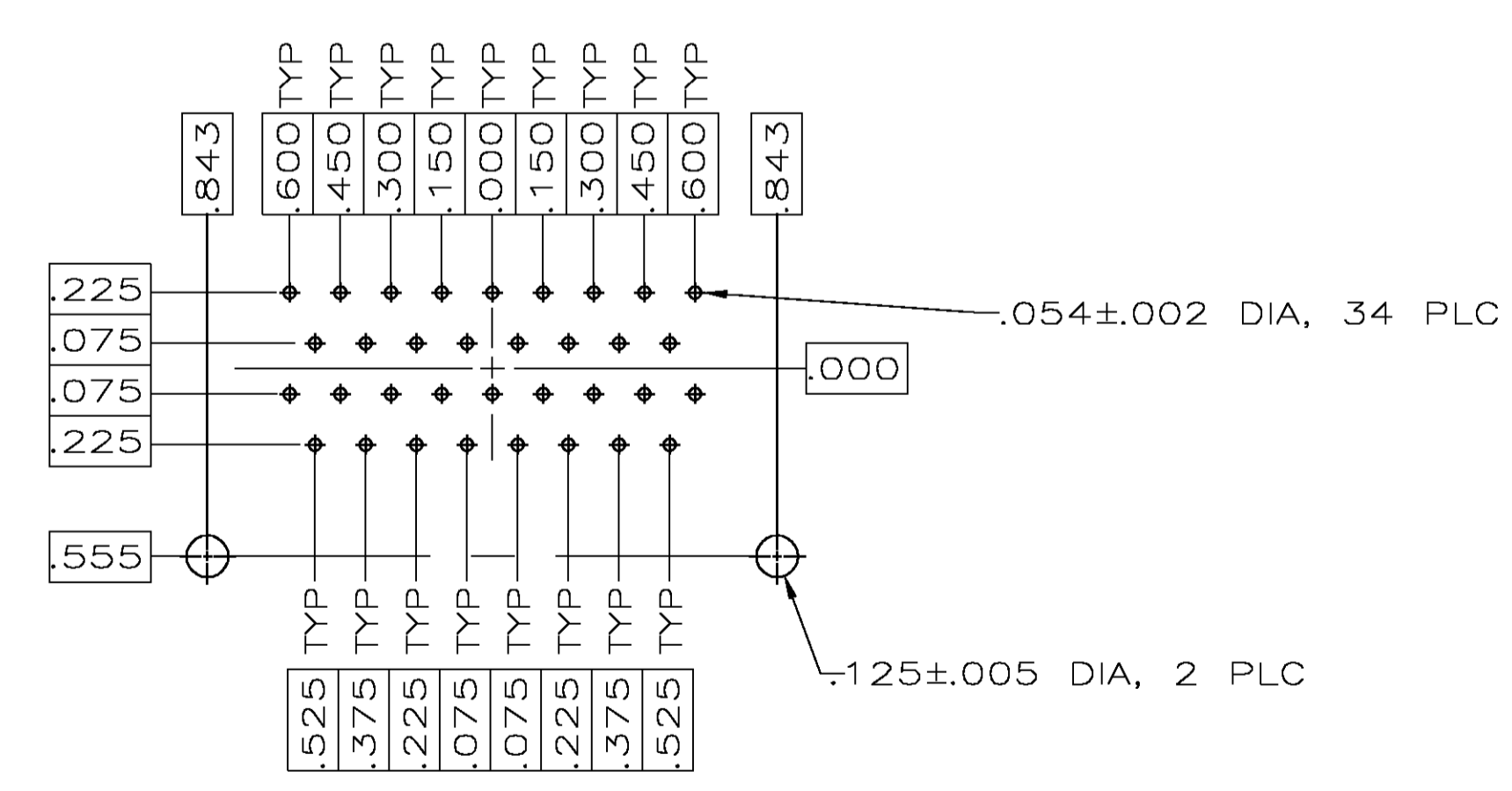
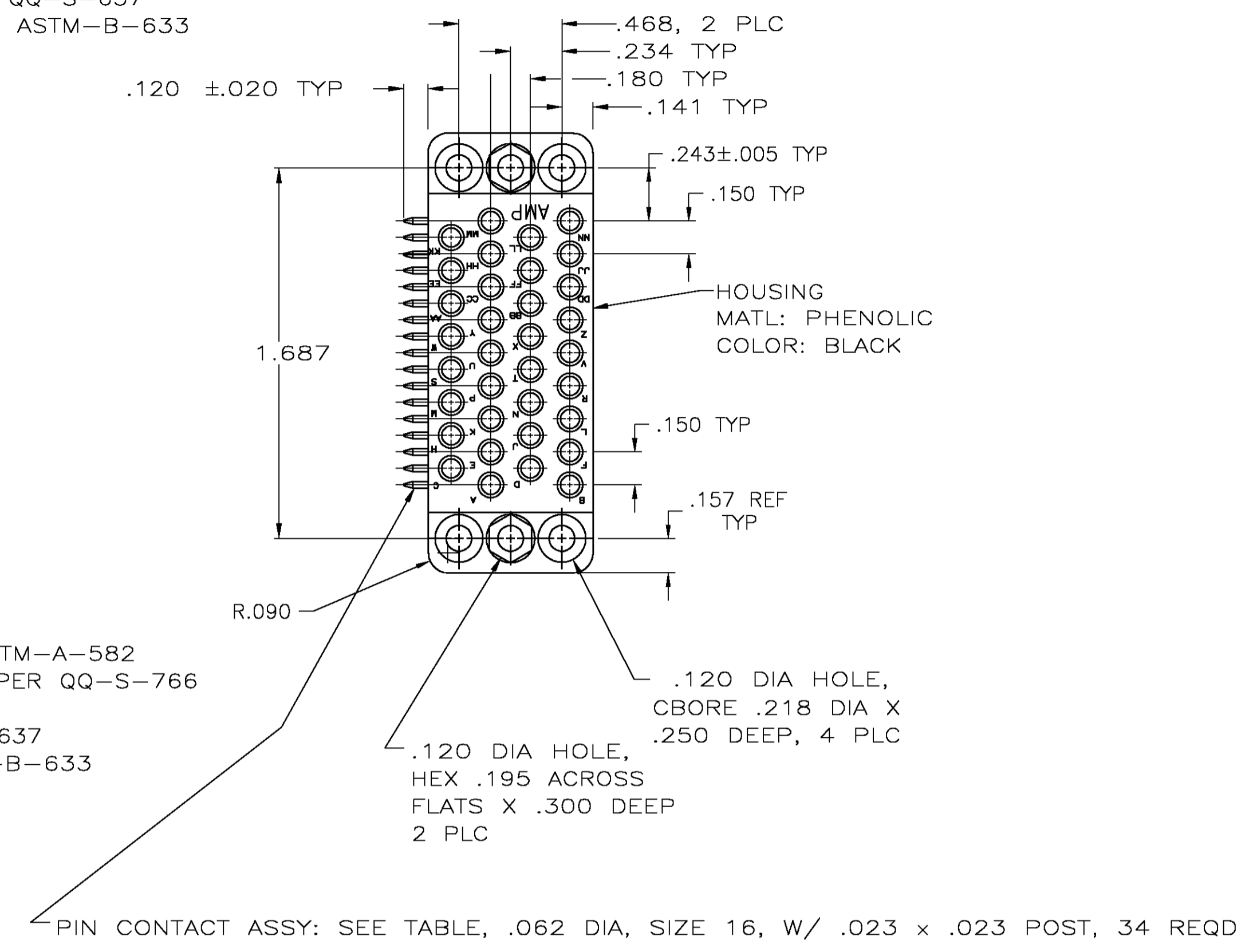
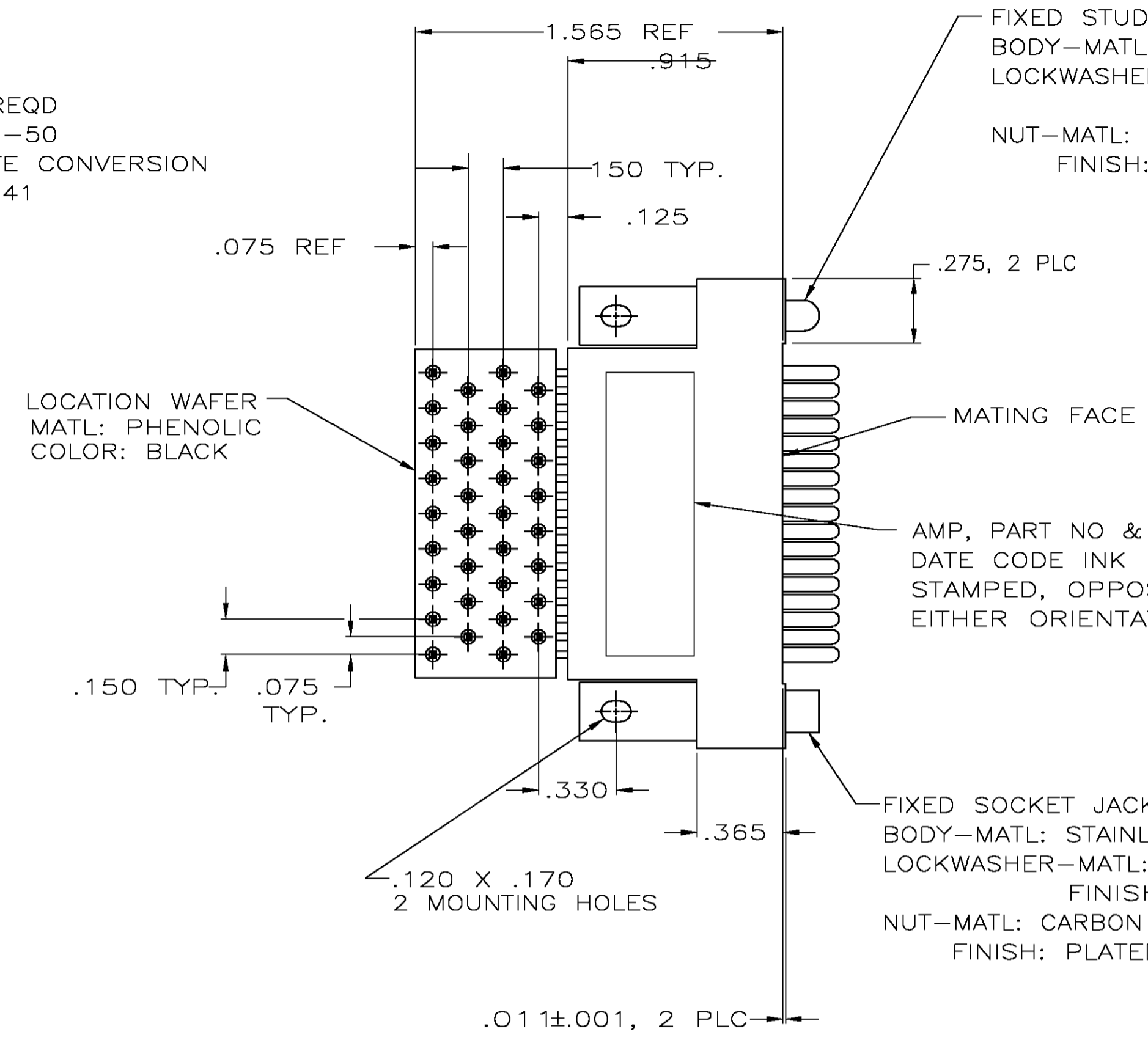
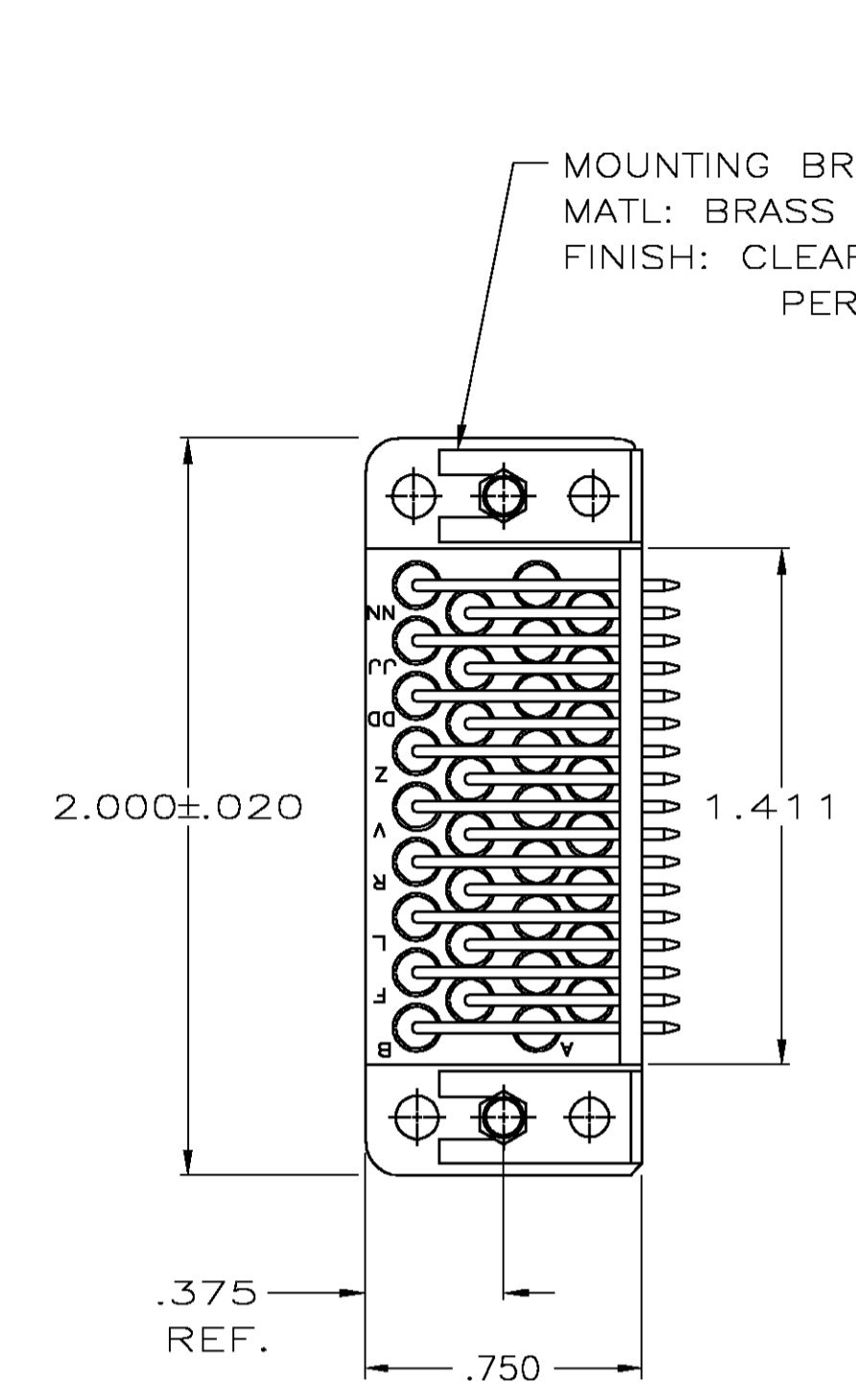

- △ BODY-MATL: BRASS PER MIL-C-50.  
 FINISH: PLATED GOLD .000030 THK PER MIL-G-45204 FOR A LENGTH OF .200 MIN FROM MATING END, .000100 MIN TIN-LEAD PER MIL-T-10727 IN WIRE BARREL AREA, BOTH OVER NICKEL .000050 THK PER QQ-N-290.  
 SPRING-MATL: STAINLESS STEEL PER QQ-S-766.  
 POST-MATL: BRASS PER ASTM-B-134.  
 FINISH: PLATED MATTE TIN-LEAD PER MIL-T-10727 OVER NICKEL .000050 THK PER QQ-N-290.
- △ BODY-MATL: BRASS PER MIL-C-50.  
 FINISH: PLATED GOLD .000030 THK PER MIL-G-45204 FOR A LENGTH OF .200 MIN FROM MATING END, .000100 MIN TIN PER MIL-T-10727 IN WIRE BARREL AREA, BOTH OVER NICKEL .000050 THK PER QQ-N-290.  
 SPRING-MATL: STAINLESS STEEL PER QQ-S-766.  
 POST-MATL: BRASS PER ASTM-B-134.  
 FINISH: PLATED MATTE TIN PER MIL-T-10727 OVER NICKEL .000050 THK PER QQ-N-290.

|                |             |
|----------------|-------------|
| △              | 213289-2    |
| △              | 213289-1    |
| CONTACT FINISH | PART NUMBER |

|  |                     |                          |   |
|--|---------------------|--------------------------|---|
| THIS DRAWING IS A CONTROLLED DOCUMENT. |                     | DIN M. HOFFECKER 5-12-86 | Tyco Electronics Corporation<br>Harrisburg, Pa 17105-3608         |
| DIMENSIONS: INCHES                     |                     | CHK L. LAWVER 5-12-86    |   |
| TOLERANCES UNLESS OTHERWISE SPECIFIED: |                     | APVD                     | NAME  |
| 0 PLC ± -                              | 1 PLC ± -           | PRODUCT SPEC             | CONNECTOR ASSEMBLY,<br>PIN, 34 POSITION,<br>RIGHT ANGLE, M SERIES |
| 2 PLC ± -                              | 3 PLC ± -           | APPLICATION SPEC         | SIZE CAGE CODE DRAWING NO   |
| 4 PLC ± -                              | ANGLES ± -          | WEIGHT                   | A1 00779 C=213289   |
| MATERIAL SEE CALLOUTS                  | FINISH SEE CALLOUTS | CUSTOMER DRAWING         | RESTRICTED TO   |
|  |                     | SCALE 2:1                | SHEET 1 OF 1 REV L  |