



Chipsmall Limited consists of a professional team with an average of over 10 year of expertise in the distribution of electronic components. Based in Hongkong, we have already established firm and mutual-benefit business relationships with customers from,Europe,America and south Asia,supplying obsolete and hard-to-find components to meet their specific needs.

With the principle of “Quality Parts,Customers Priority,Honest Operation,and Considerate Service”,our business mainly focus on the distribution of electronic components. Line cards we deal with include Microchip,ALPS,ROHM,Xilinx,Pulse,ON,Everlight and Freescale. Main products comprise IC,Modules,Potentiometer,IC Socket,Relay,Connector.Our parts cover such applications as commercial,industrial, and automotives areas.

We are looking forward to setting up business relationship with you and hope to provide you with the best service and solution. Let us make a better world for our industry!



## Contact us

Tel: +86-755-8981 8866 Fax: +86-755-8427 6832

Email & Skype: info@chipsmall.com Web: www.chipsmall.com

Address: A1208, Overseas Decoration Building, #122 Zhenhua RD., Futian, Shenzhen, China





## ESSENTIAL INFORMATION

BUILD INSTRUCTIONS  
CHECKING YOUR PCB & FAULT-FINDING  
MECHANICAL DETAILS  
HOW THE KIT WORKS

CREATE YOUR OWN SPEAKER DOCK WITH THIS

# DELUXE STEREO AMPLIFIER KIT

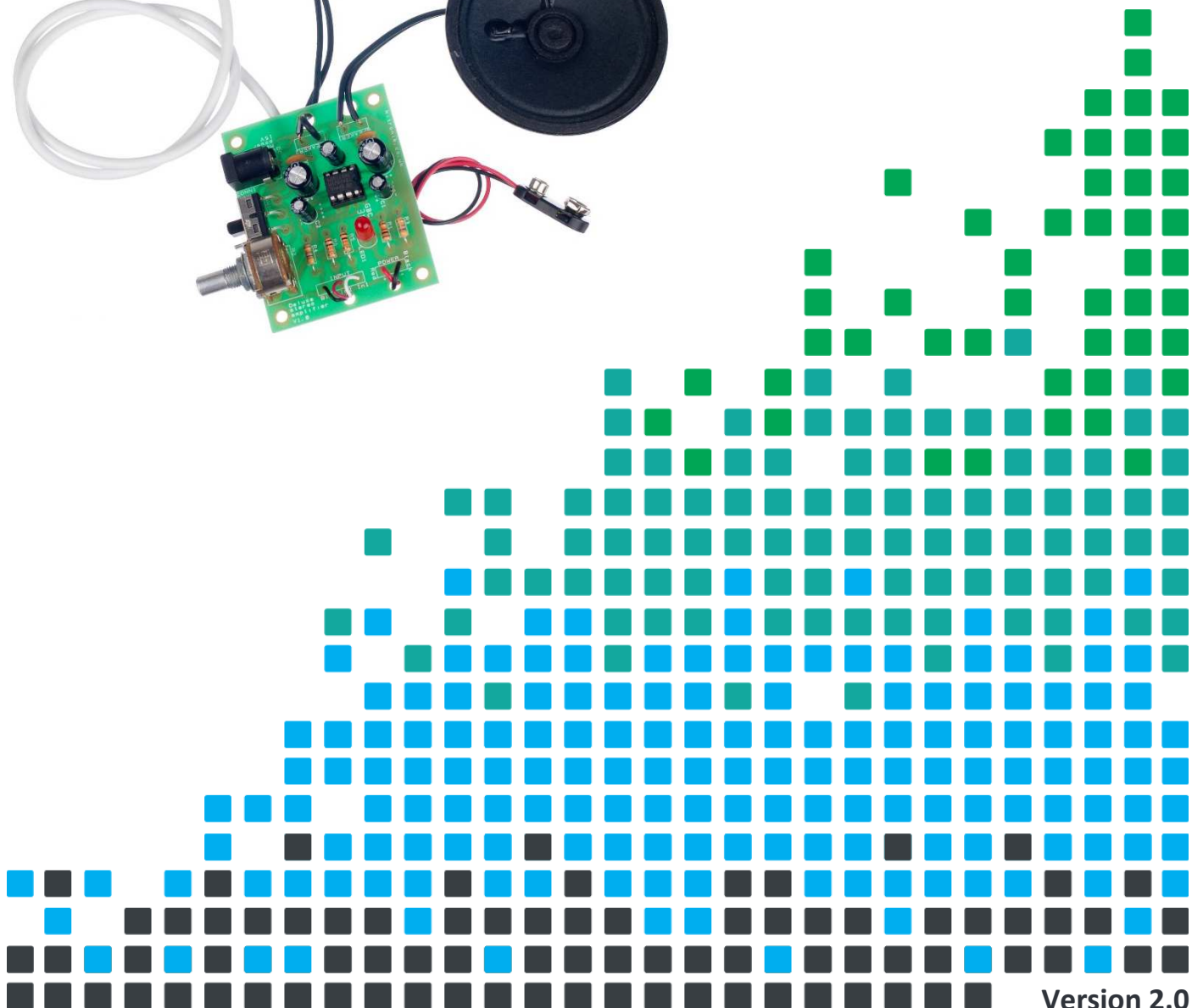

Version 2.0

## Build Instructions

Before you start, take a look at the Printed Circuit Board (PCB). The components go in the side with the writing on and the solder goes on the side with the tracks and silver pads.

### 1 PLACE RESISTORS

Start with the five resistors:  
The text on the PCB shows where R1, R2 etc go.  
Ensure that you put the resistors in the right place.

PCB Ref	Value	Colour Bands
R1	1K	Brown, black, red
R3 & R4	4.7Ω	Yellow, purple, gold
R5 & R6	10K	Brown, black, orange



### 2 SOLDER THE IC HOLDER

Solder the Integrated Circuit (IC) holder in to IC1. When putting this into the board, be sure to get it the right way around. The notch on the IC holder should line up with the notch on the lines marked on the PCB. Once this has been done insert the 8 pin IC into this socket, making sure that the notch on the device matches the notch on the IC holder.

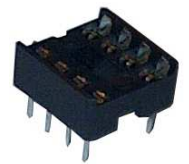

### 3 SOLDER THE CERAMIC DISC CAPACITORS

There are two ceramic disc capacitors. These should be soldered into C6 and C7. It does not matter which way around they go.

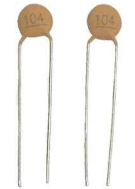

### 4 SOLDER THE LED

Solder the LED into the PCB where it is labelled LED1. When putting it into the board, make sure that the flat edge on the LED matches the outline on the PCB.



### 5 SOLDER THE SWITCH

Solder the PCB Mount Right Angled On / Off Switch into SW1. The row of three pins that exit the back of the switch must be soldered but it doesn't matter if you can't solder the other two pins.

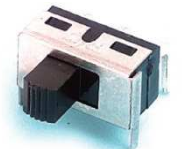

### 6 SOLDER THE POWER SOCKET

Solder the DC power socket into the PCB where it is labelled CONN1.



## 7

### SOLDER THE ELECTROLYTIC CAPACITORS

Now solder in the five electrolytic capacitors (an example is shown right). The capacitors have text printed on the side that indicates their value. The capacitors are placed as:

C1 and C2 = 100 $\mu$ F.    C3 = 10 $\mu$ F.    C4 and C5 = 470 $\mu$ F.

Make sure that the capacitors are the correct way around. The capacitors have a '-' sign marked on them, which should match the same sign on the PCB.



## 8

### SOLDER THE DUAL POTENTIOMETER

Solder the potentiometer into the PCB where it is labelled R2. Make sure that the volume knob is facing away from the PCB.



## 9

### CONNECT THE SPEAKERS

The kit is supplied with a metre of twin cable. This cable will be used to connect the two speakers. You will need to cut this to the required length for each speaker in your enclosure design.

Take each piece of wire that you have cut off and strip the ends of the wire. Connect one end of each to the two terminals on the speaker (shown right), and the other end of each to the terminals on the PCB marked 'SPEAKER1' and 'SPEAKER2', after feeding it through the strain relief hole. It does not matter which way around these connections go.



## 10

### ATTACH THE BATTERY CLIP

The PP3 battery clip should be attached to the terminals labelled 'POWER'. Connect the red wire to '+' and the black wire to '-' after feeding it through the strain relief hole.



## 11

### CONNECT THE AUDIO CABLE

The stereo Jack / iPod lead should be connected to the 'INPUT' terminal. First, feed the wires through the strain relief hole. The black wire should be connected to the terminal labelled 'BLK'. The other two can go to either of the two remaining inputs.

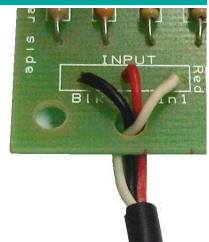

## Checking Your Amplifier PCB

Carefully check the following before you insert the batteries:

**Audio equipment may become damaged if connected to an incorrectly built amplifier.**

### Check the bottom of the board to ensure that:

- All holes (except the 4 large (3mm) holes in the corners) are filled with the lead of a component.
- All these leads are soldered.
- Pins next to each other are not soldered together.

### Check the top of the board to ensure that:

- The speakers, power lead etc. are connected to the right place.
- The '-' on the capacitors match the same marks on the PCB.
- The colour bands on R1 are brown, black, red.
- The colour bands on R3 & R4 are yellow, purple, gold.
- The colour bands on R5 & R6 are brown, black, orange.
- C3 is a 10 $\mu$ F capacitor.
- The battery clip red and black wires match the red and black text on the PCB.
- The notch on the IC is next to C1 & C4.
- The flat edge on the LED matches the outline on the PCB.



## Fault finding flow chart

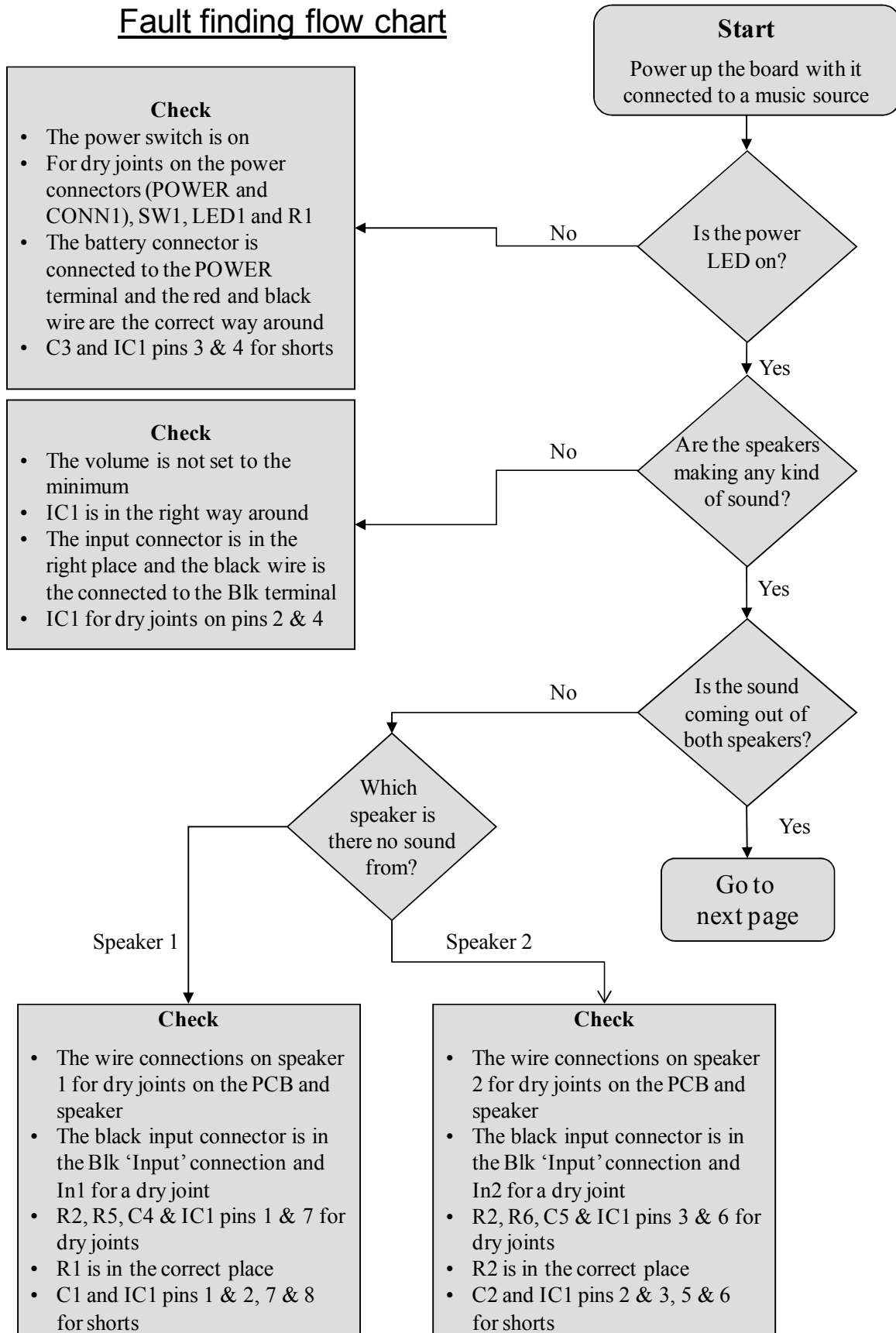

## Fault finding flow chart continued

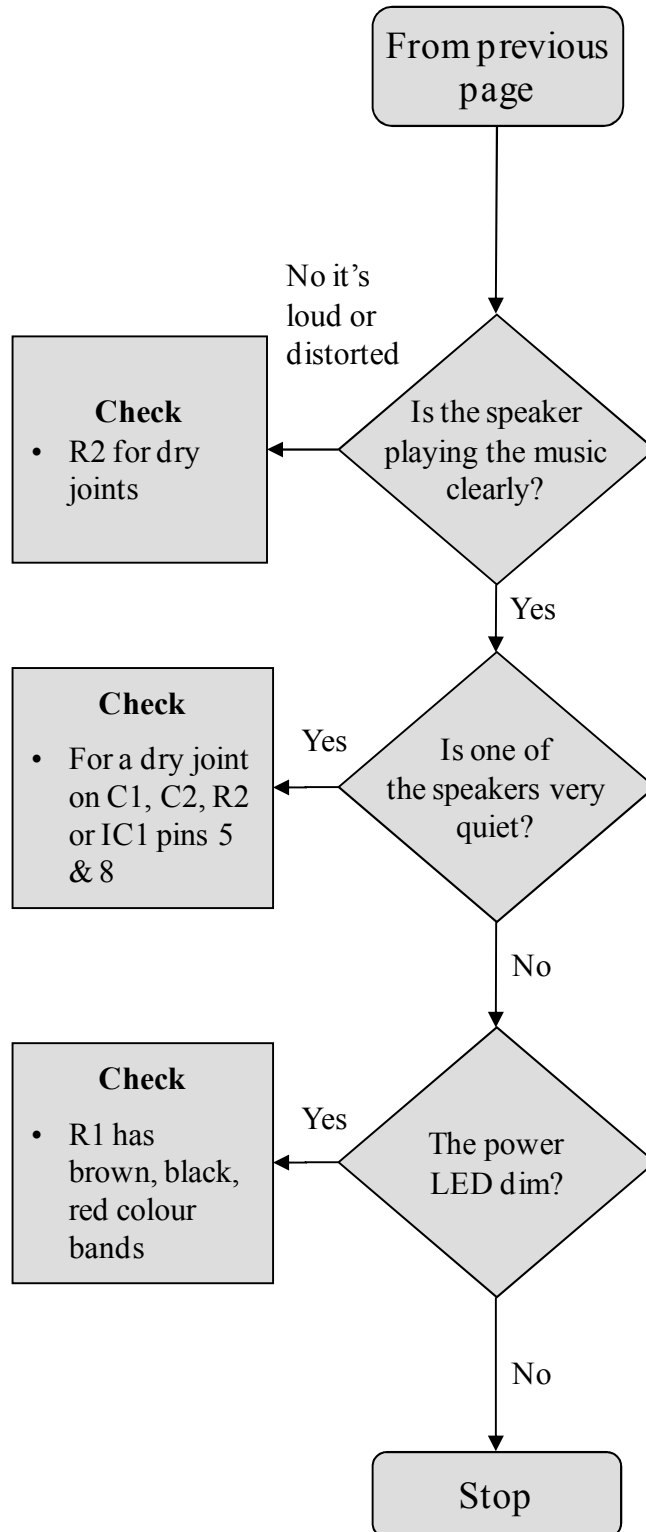

## Designing the Enclosure

When you design the enclosure, you will need to consider:

- The size of the PCB (below left, height including components = 15mm).
- How big the batteries are (if used).
- How to mount the two speakers (below right).
- How to allow the audio cable out of the box.
- Are you making the amplifier for a particular MP3 player, if so, should the MP3 player go in the box?
- Position of the volume control, DC power jack, switch and LED.

These technical drawings of the amplifier PCB and speaker should help you to plan this.

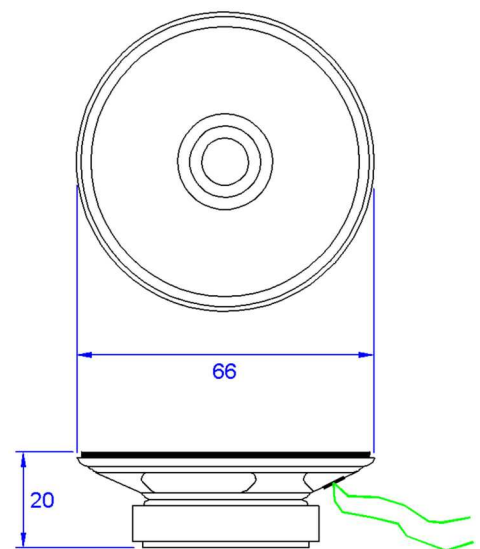
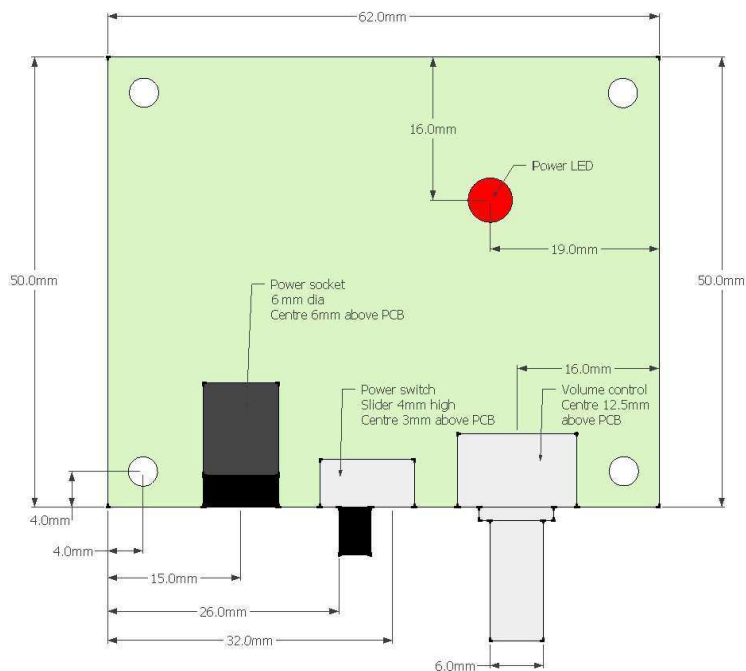

<p>Diagram showing the PCB mounted to the enclosure. The PCB is placed on top of a hex spacer, which is secured to the enclosure by two M3 bolts. Labels include: P.C.B., SPACER, ENCLOSURE, and 2 X M3 BOLTS.</p>	<p><b>Mounting the PCB to the enclosure</b></p> <p>The drawing to the left shows how a hex spacer can be used with two bolts to fix the PCB to the enclosure.</p> <p><i>Your PCB has four mounting holes designed to take M3 bolts.</i></p>
--	---





## How the Amplifier Works

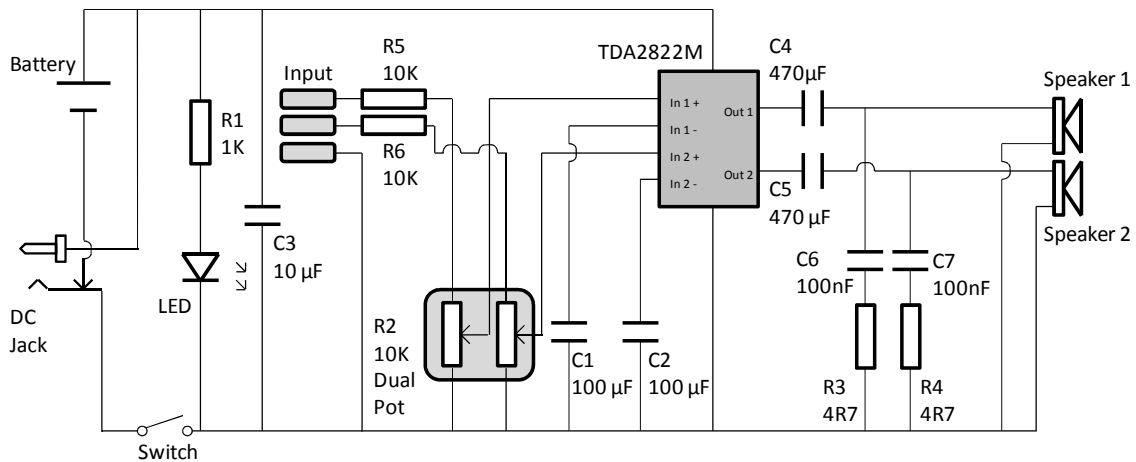

At the centre of the circuit is an audio amplifier Integrated Circuit or IC. Inside the IC are lots of transistors, which are connected together to allow the small input signal to be amplified into a more powerful output that can drive a speaker.

All amplifiers need to use feedback to ensure that the amount of gain stays the same. This allows the output to be an exact copy of the input, just bigger. The gain is the number of times bigger the output is compared to the input. So if an amplifier has a gain of 10 and there is 1 volt on the input, there will be 10 volts on the output. An operational amplifier has two inputs, these are called the inverting (-) and non-inverting (+) inputs. The output of the operational amplifier is the voltage on the non-inverting input less the voltage on the inverting input, multiplied by the amplifier's gain. In theory, an operational amplifier has unlimited gain so if the non-inverting input is a fraction higher than the inverting input (there is more + than -), the output will go up to the supply voltage. Change the inputs around and the output will go to zero volts. In this format the operational amplifier is acting as a comparator, it compares the two inputs and changes the output accordingly.

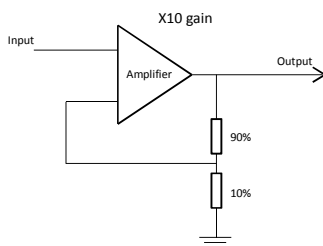

With an infinite gain the amplifier is no good to amplify audio, which is where the feedback comes in. By making one of the inputs a percentage of the output the gain can be fixed, which allows the output to be a copy of the input but bigger. Now when the two inputs are compared and the output is adjusted, instead of it going up or down until it reaches 0 volts or V+, it stops at the point when the two inputs match and the output is at the required voltage.

Looking at the circuit diagram for the audio amplifier it's not obvious where the feedback is, this is because it is inside the IC. The TDA2822M or NJM2073D chip has fixed the gain so the output is about 90 times bigger than the input. To make the gain useful in our application there is a potential divider on each channel that is fed into the IC (R2+R5 and R2+R6). Each of these reduces the input signal to a percentage of the original signal. As R2 is a variable potentiometer, it can be used to vary this percentage, which in turn varies the output volume. C3 is connected across the supply to make sure that it remains stable. The other capacitors have a filtering role, either to cut out high frequency noise or get the best out of the speaker.

A power switch is inserted in the ground (0V) power line, which is used to turn the amplifier on and off. There is also a power LED that lights up when the power switch is on. R1 is used to limit the current flowing into this LED, which stops it drawing too much power, which over time will damage the LED. Power is supplied to the circuit by either a battery or a DC power socket. If a power supply is plugged into the DC power socket, the battery is automatically disconnected.



## Online Information

Two sets of information can be downloaded from the product page where the kit can also be reordered from. The 'Essential Information' contains all of the information that you need to get started with the kit and the 'Teaching Resources' contains more information on soldering, components used in the kit, educational schemes of work and so on and also includes the essentials. Download from:

[www.kitronik.co.uk/2141](http://www.kitronik.co.uk/2141)



This kit is designed and manufactured in the UK by Kitronik

---

**Telephone:** +44 (0) 845 8380781

**Sales email:** sales@kitronik.co.uk

**Tech support email:** support@kitronik.co.uk

**Web:** www.kitronik.co.uk



[www.kitronik.co.uk/twitter](http://www.kitronik.co.uk/twitter)



[www.kitronik.co.uk/facebook](http://www.kitronik.co.uk/facebook)



[www.kitronik.co.uk/youtube](http://www.kitronik.co.uk/youtube)



[www.kitronik.co.uk/google](http://www.kitronik.co.uk/google)

---

Every effort has been made to ensure that these notes are correct, however Kitronik accept no responsibility for issues arising from errors / omissions in the notes.

© Kitronik Ltd - Any unauthorised copying / duplication of this booklet or part thereof for purposes except for use with Kitronik project kits is not allowed without Kitronik's prior consent.

---

