



Chipsmall Limited consists of a professional team with an average of over 10 year of expertise in the distribution of electronic components. Based in Hongkong, we have already established firm and mutual-benefit business relationships with customers from,Europe,America and south Asia,supplying obsolete and hard-to-find components to meet their specific needs.

With the principle of “Quality Parts,Customers Priority,Honest Operation,and Considerate Service”,our business mainly focus on the distribution of electronic components. Line cards we deal with include Microchip,ALPS,ROHM,Xilinx,Pulse,ON,Everlight and Freescale. Main products comprise IC,Modules,Potentiometer,IC Socket,Relay,Connector.Our parts cover such applications as commercial,industrial, and automotives areas.

We are looking forward to setting up business relationship with you and hope to provide you with the best service and solution. Let us make a better world for our industry!



Contact us

Tel: +86-755-8981 8866 Fax: +86-755-8427 6832

Email & Skype: info@chipsmall.com Web: www.chipsmall.com

Address: A1208, Overseas Decoration Building, #122 Zhenhua RD., Futian, Shenzhen, China





ESSENTIAL INFORMATION

BUILD INSTRUCTIONS
CHECKING YOUR PCB & FAULT-FINDING
MECHANICAL DETAILS
HOW THE KIT WORKS

PLAY IT LOUD AND PLAY IT PROUD WITH THIS

HIGH POWER AMPLIFIER KIT

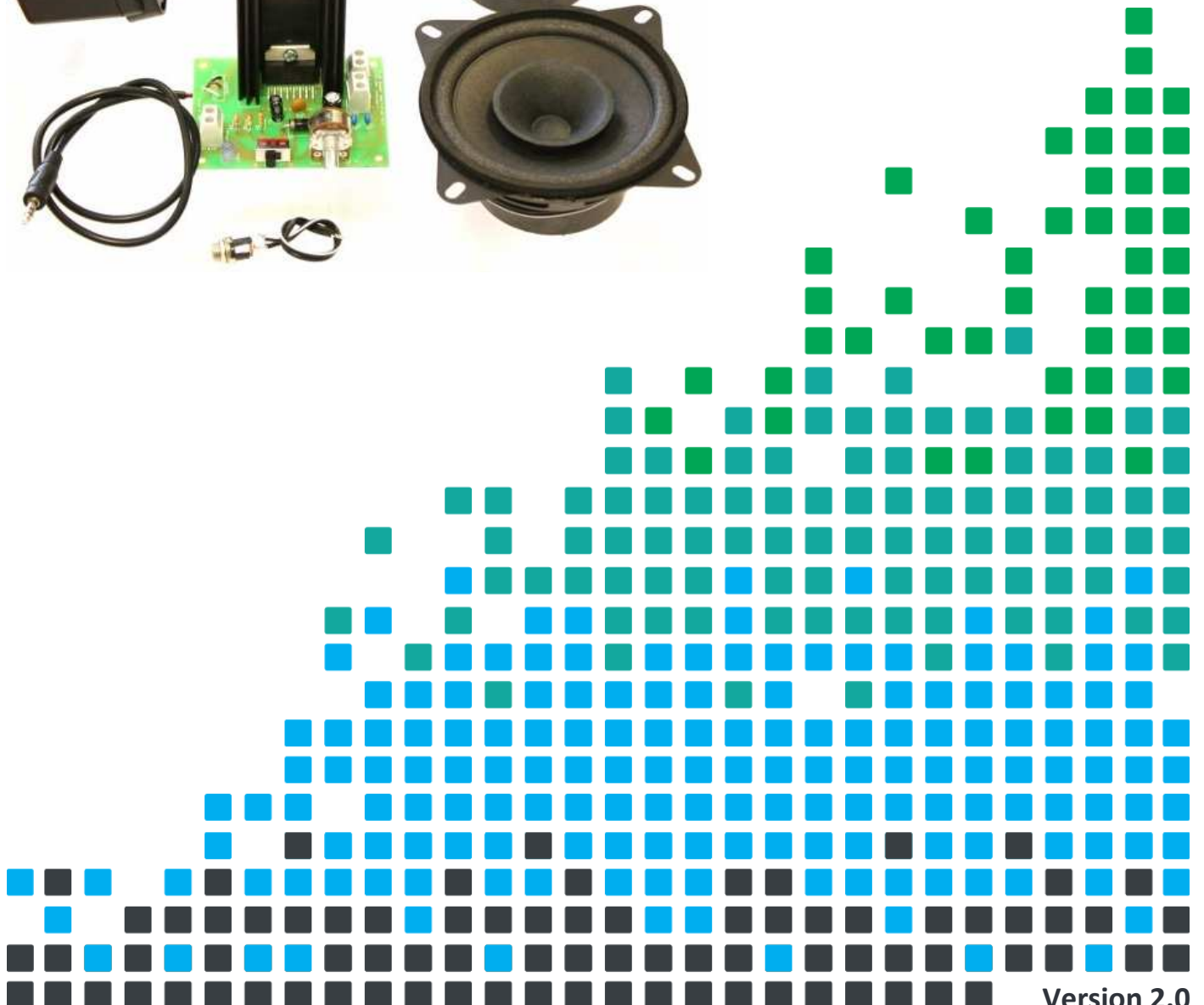

Version 2.0

Build Instructions

Before you start, take a look at the Printed Circuit Board (PCB). The components go in the side with the writing on and the solder goes on the side with the tracks and silver pads.

1 PLACE RESISTORS

Start with the three resistors:
The text on the PCB shows where R1, R2 etc go.
Ensure that you put the resistors in the right place.

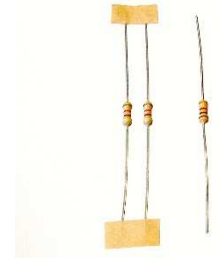

PCB Ref	Value	Colour Bands
R1 & R2	47K Ω	Yellow, purple, orange
R3	1K Ω	Brown, black, red

2 SOLDER THE DIODE

Solder the diode into the board. When putting this into the board, be sure to get it the right way around. The band on the diode must match up with the band on the PCB. The diode is marked D1.



3 SOLDER THE PCB MOUNT SWITCH

Solder the PCB Mount Right Angled On / Off Switch into SW1 on the PCB. The row of three pins that exit the back of the switch must be soldered but it doesn't matter if you can't solder the other two pins.



4 SOLDER THE CERAMIC DISC CAPACITORS

There are three ceramic disc capacitors. The 100nF capacitor should be soldered into C2 on the PCB. This capacitor has the text 104 printed on it. Then the two 220nF capacitors should be soldered into C3 and C5 on the PCB.



5 SOLDER THE LED

Solder the LED into the PCB where it is labelled LED1. When putting it into the board, **make sure that the flat edge on the LED matches the outline on the PCB.**



6

SOLDER THE ELECTROLYTIC CAPACITORS

Now solder the two electrolytic capacitors. The capacitors have text printed on the side that indicates their value. The 10 μ F capacitors should be soldered into C4 on the PCB and the 470 μ F capacitor should be soldered into C1. Make sure that the capacitors are the correct way around. **The capacitors have a '-' sign marked on them, which should match the same sign on the PCB.**

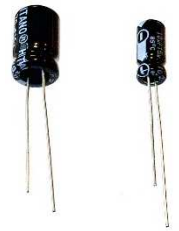

7

FIT THE TERMINAL BLOCKS

There are three terminal blocks that allow the power and speaker wires to be attached to the PCB. These go into the PCB where it is labelled 'POWER', 'OUT1' and 'OUT2'. Make sure that they face towards the edge of the PCB.



8

SOLDER THE DUAL POTENTIOMETER

Solder the dual potentiometer into the PCB where it is labelled R4. Make sure that the volume knob is facing away from the PCB.



9

ADD HEAT SINK AND AMPLIFIER IC

The next step is to add the heat sink and amplifier IC. The best way to do this is in the following order:

- Solder the heat sink to the PCB. The heat sink must be orientated so that it matches the outline on the PCB. As the heat sink is a very large part, it may take longer than normal for it to be soldered. If you have a temperature controlled soldering iron, turn it up to full just for the heat sink.
- Insert the amplifier IC into the PCB and attach it to the heat sink by using the nut and bolt.
- Solder the IC pins to the PCB.



10

CONNECT THE SPEAKERS

The kit is supplied with a meter of twin cable. This cable will be used to connect the two speakers. You will need to cut this to the required length to connect each speaker in your enclosure design (reserving a section for connecting the power jack later).

Take each piece of twin cable and strip the ends of the wire. Connect one end of each wire to the two terminals on each speaker (as shown). You will see that the speakers have '+' and '-' indicators. At this stage it doesn't matter which way around the wire is connected.



Take the cable connected to one speaker and connect it to the terminal block labeled 'OUT1' on the PCB. The connections on the terminal blocks are also labeled with a '+' and '-'. The '+' on the PCB needs to go to the '+' on the speaker and '-' to '-'.

Repeat with the second speaker, this time connecting to the terminal block labelled 'OUT2'.

11

CONNECT THE POWER CONNECTOR

The kit is supplied with a power connector that can be mounted into the side of a case designed to hold your amplifier. To connect this to the amplifier board, it needs a piece of cable (reserved earlier in step 10) connecting to it. There are three connections on the connector. The middle / rear connection should have one wire connected to it and the top connector should have the other wire connected to it as shown in the diagram.

Look at the diagram above and note which wire is positive / negative. They can be connected to the terminal block labelled 'POWER' ensuring the polarity of the wires matches the '+' '-' identifiers in the PCB.

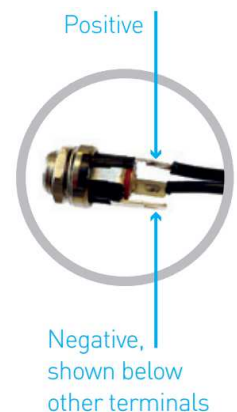

12

CONNECT THE AUDIO CABLE

The stereo Jack / iPod lead should be connected to the 'INPUT' terminal. First feed the wires through the strain relief hole. The black wire should be connected to the terminal labelled 'BLK'. The other two wires can go to either of the two remaining inputs.

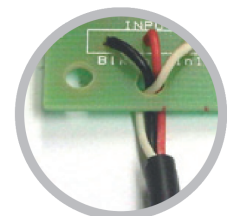

Checking Your Amplifier PCB

Carefully check the following before you connect the power:

Audio equipment may become damaged if connected to an incorrectly built amplifier.

Check the bottom of the board to ensure that:

- All holes (except the 4 large (3mm) holes in the corners) are filled with the lead of a component.
- All these leads are soldered.
- Pins next to each other are not soldered together.

Check the top of the board to ensure that:

- The speakers, power lead and audio connections are connected to the right place.
- The '-' on the capacitors match the same marks on the PCB.
- The colour bands on R3 are brown, black, red.
- The silver band on D1 is next to the on / off switch.
- The 'Black' labelled terminal on the 'POWER' connection goes to the centre pin on the DC Jack.
- The 'Black' labelled terminal on the 'AUDIO' connection has the black wire connected to it.
- The flat edge on the LED matches the outline on the PCB.



Fault finding flow chart

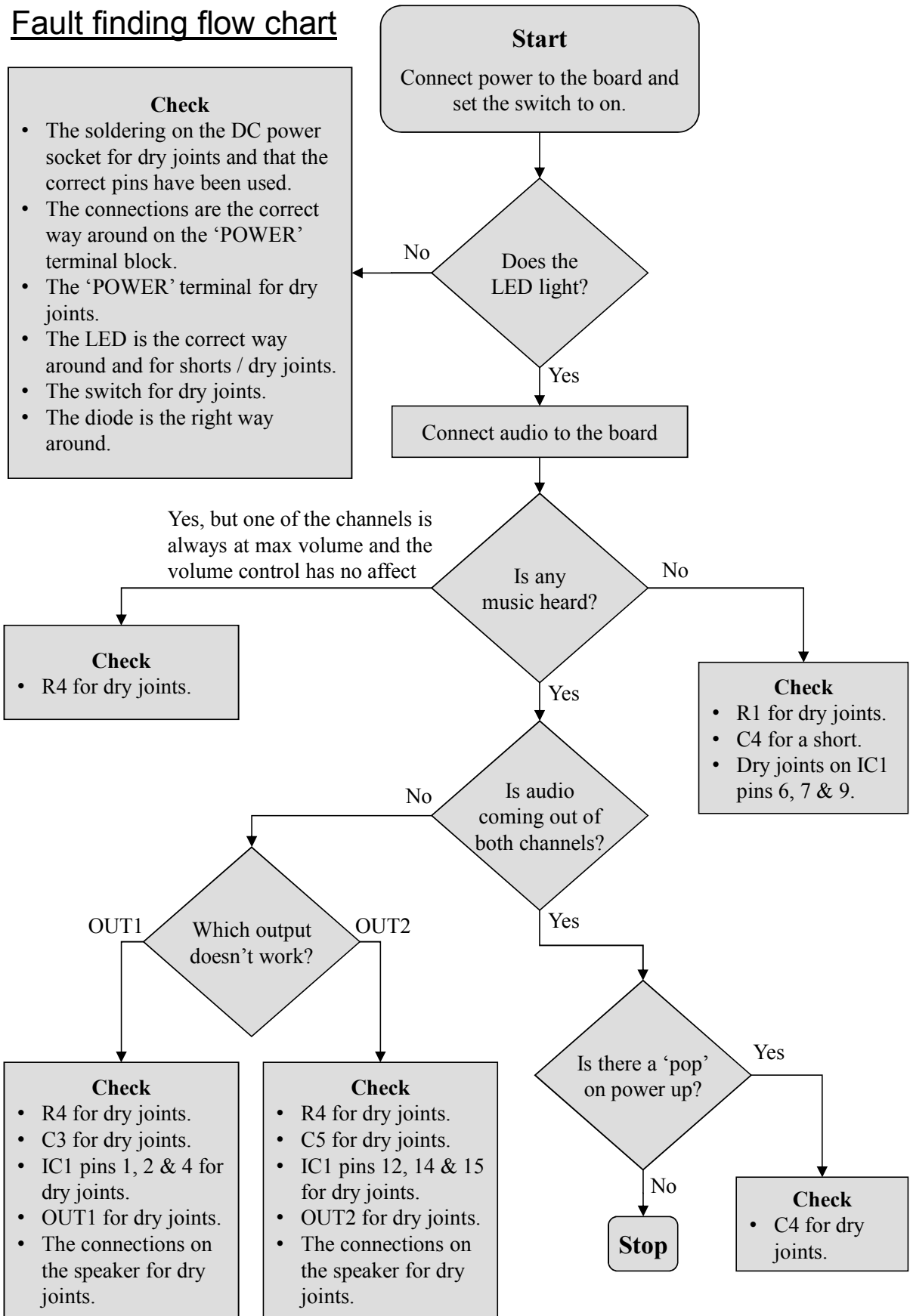

Designing the Enclosure

When you design the enclosure, you will need to consider:

- The size of the PCB (below left, height including components = 65mm).
- How to mount the speaker (below right).
- How to allow the audio cable out of the box.
- Are you making the amplifier for a particular MP3 player, if so should the player go in the box?

These technical drawings of the amplifier PCB and speaker should help you to plan this.

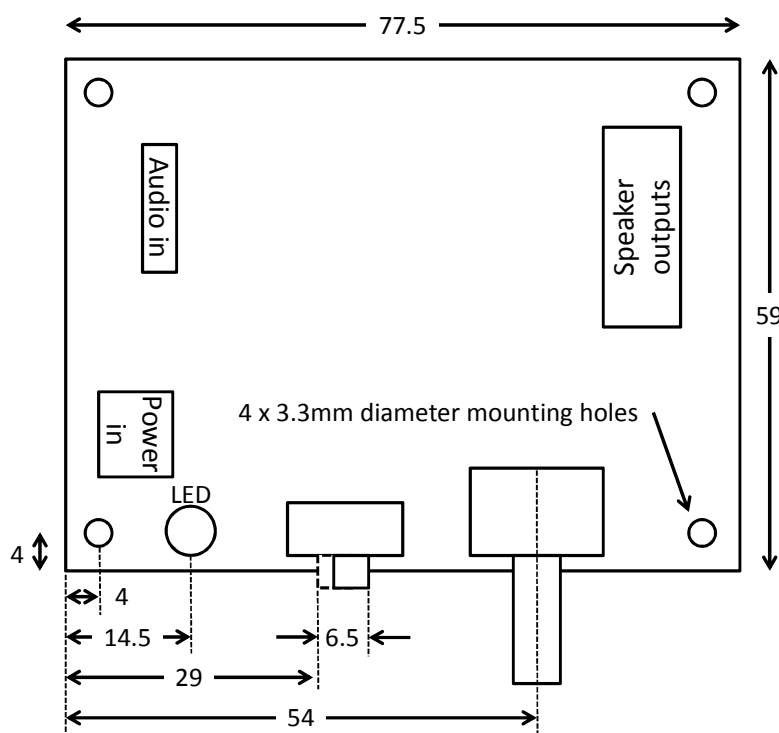

LED shown mounted front facing with 90° bent leads

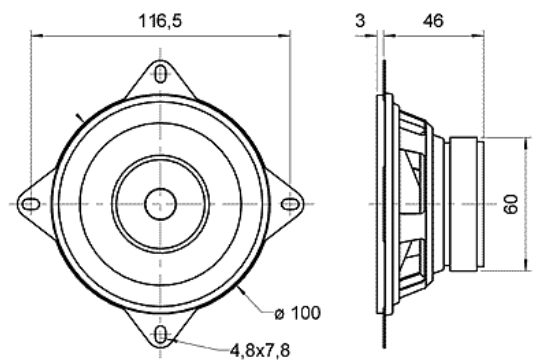
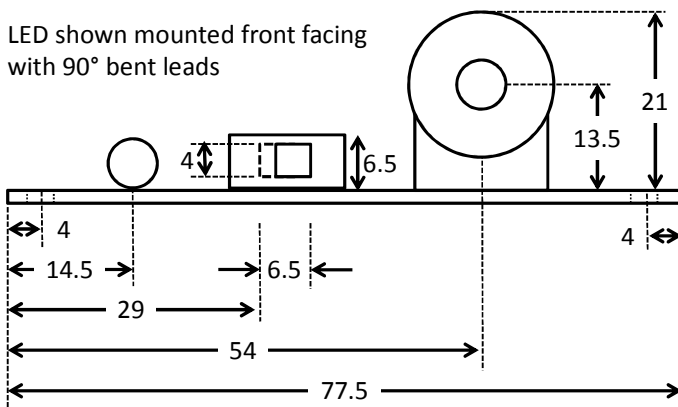

All dimensions in mm

Mounting the PCB to the enclosure

The drawing (below) shows how a hex spacer can be used with two bolts to fix the PCB to the enclosure.

Your PCB has four mounting holes designed to take M3 bolts

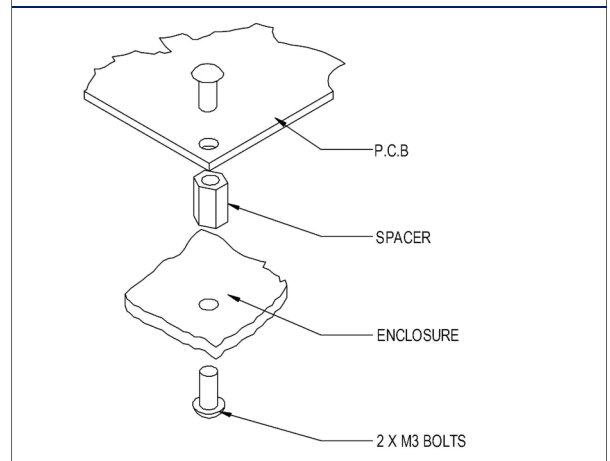

How the Amplifier Works

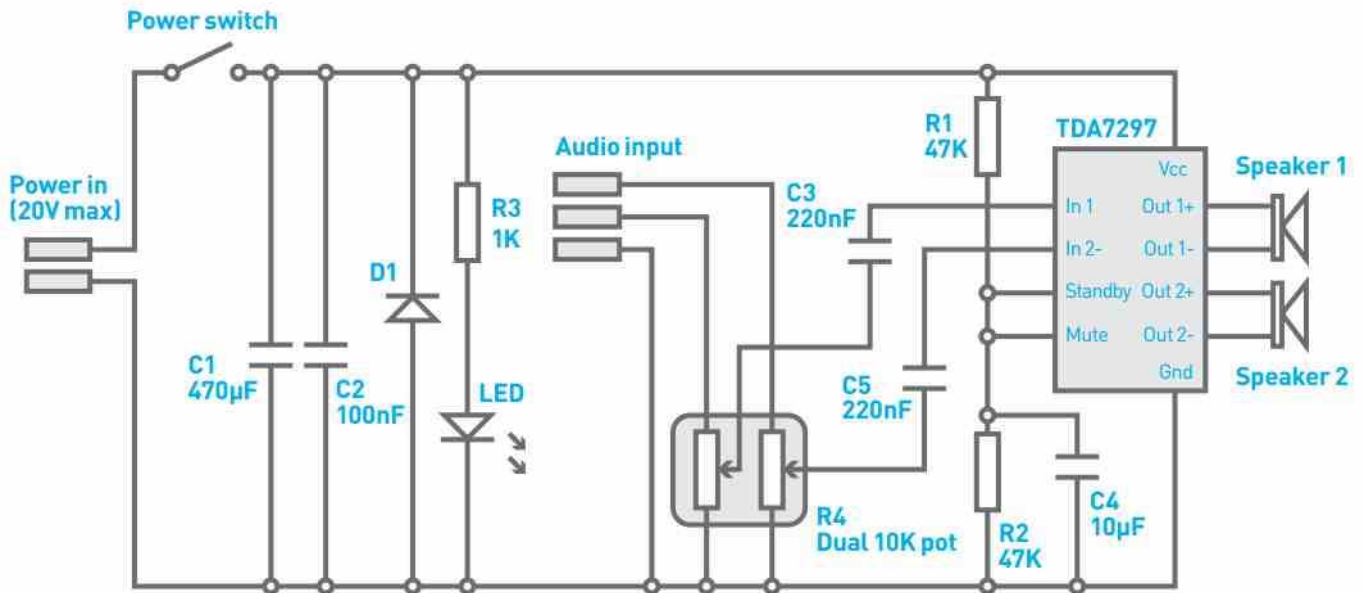

The High Power Amplifier is a fairly simple circuit as all of the hard work is done by the amplifier IC. Working from left to right on the circuit diagram, the power comes into the board and goes through a power switch. When the power switch is off, this isolates power from the whole circuit. When the switch is on, the LED will light. The brightness of the LED is set by the resistor R3. The capacitors C1 and C2 are present to ensure that the power supply to the amplifier IC is stable. The diode D1 is included so that if the power is connected to the board the wrong way around, it shorts the power supply. The power supply supplied with the kit instantly cuts the power. This is needed to protect the audio amplifier IC.

In the middle of the circuit is the audio input, this is divided down by the dual wiper potentiometer R4, which works as a volume control. The inputs are de-coupled into the amplifier IC through the capacitors C3 & C5. In order to prevent noise on power up, the resistors R1, R2 and the capacitor C4 keep the mute and standby pins in a low state until the power supply has stabilised. The amplifier amplifies both the voltage and the current of the input and this is then driven into the two speakers.



Online Information

Two sets of information can be downloaded from the product page where the kit can also be reordered from. The 'Essential Information' contains all of the information that you need to get started with the kit and the 'Teaching Resources' contains more information on soldering, components used in the kit, educational schemes of work and so on and also includes the essentials. Download from:

www.kitronik.co.uk/2143



This kit is designed and manufactured in the UK by Kitronik

Telephone: +44 (0) 845 8380781

Sales email: sales@kitronik.co.uk

Tech support email: support@kitronik.co.uk

Web: www.kitronik.co.uk



www.kitronik.co.uk/twitter



www.kitronik.co.uk/facebook



www.kitronik.co.uk/youtube



www.kitronik.co.uk/google

Every effort has been made to ensure that these notes are correct, however Kitronik accept no responsibility for issues arising from errors / omissions in the notes.

© Kitronik Ltd - Any unauthorised copying / duplication of this booklet or part thereof for purposes except for use with Kitronik project kits is not allowed without Kitronik's prior consent.

