



Chipsmall Limited consists of a professional team with an average of over 10 year of expertise in the distribution of electronic components. Based in Hongkong, we have already established firm and mutual-benefit business relationships with customers from,Europe,America and south Asia,supplying obsolete and hard-to-find components to meet their specific needs.

With the principle of “Quality Parts,Customers Priority,Honest Operation,and Considerate Service”,our business mainly focus on the distribution of electronic components. Line cards we deal with include Microchip,ALPS,ROHM,Xilinx,Pulse,ON,Everlight and Freescale. Main products comprise IC,Modules,Potentiometer,IC Socket,Relay,Connector.Our parts cover such applications as commercial,industrial, and automotives areas.

We are looking forward to setting up business relationship with you and hope to provide you with the best service and solution. Let us make a better world for our industry!



Contact us

Tel: +86-755-8981 8866 Fax: +86-755-8427 6832

Email & Skype: info@chipsmall.com Web: www.chipsmall.com

Address: A1208, Overseas Decoration Building, #122 Zhenhua RD., Futian, Shenzhen, China





ESSENTIAL INFORMATION

- BUILD INSTRUCTIONS
- CHECKING YOUR PCB & FAULT-FINDING
- MECHANICAL DETAILS
- HOW THE KIT WORKS

CREATE YOUR OWN SPEAKER DOCK WITH THIS

MONO AMPLIFIER KIT

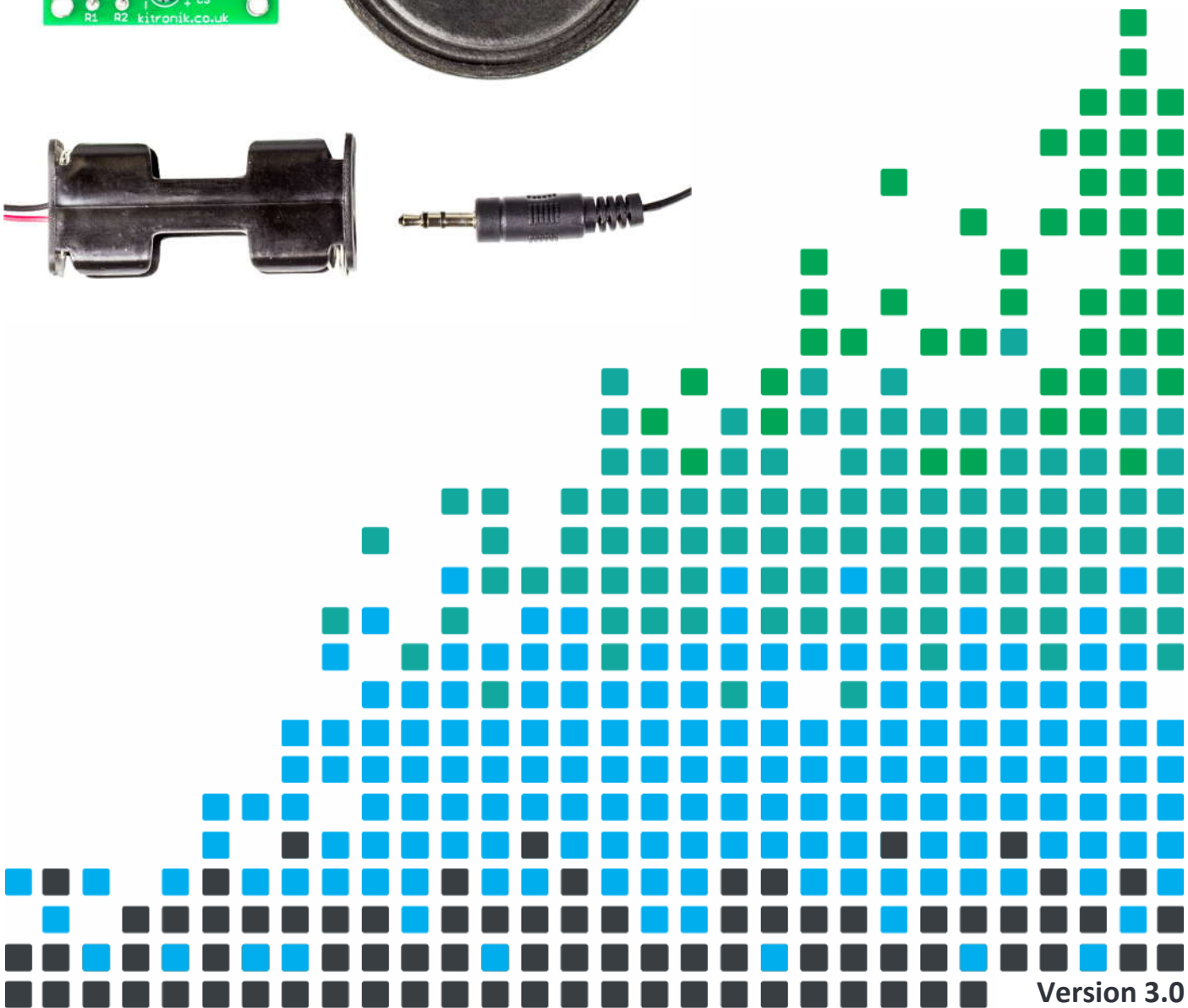
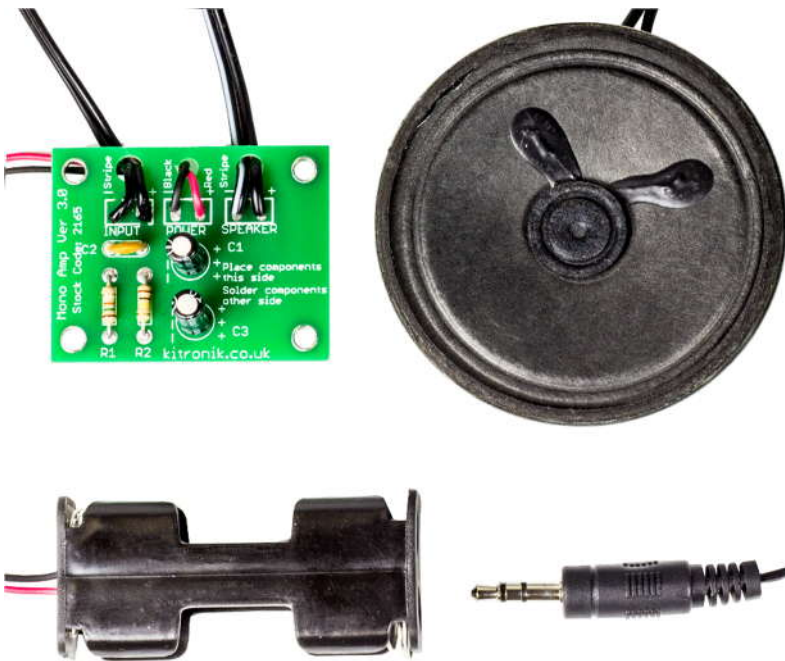

Build Instructions

Before you start, take a look at the Printed Circuit Board (PCB). The components go in the side with the writing on and the solder goes on the side with the tracks and silver pads. If the PCB is pre-built, proceed to step 4.

1 PLACE RESISTORS

Start with the two resistors:
The text on the PCB shows where R1, R2 go.
Ensure that you put the resistors in the right place.

PCB Ref	Value	Colour Bands
R1	15k	Brown, Green, Orange
R2	100k	Brown, Black, Yellow



2 SOLDER THE CERAMIC DISC CAPACITORS

There is one ceramic disc capacitor which should be soldered in to C2 on the PCB. The capacitor should be marked '104'. It does not matter which way around it goes



3 SOLDER THE ELECTROLYTIC CAPACITORS

The other two capacitors are electrolytic capacitors, they are both marked 1uF. Place these two capacitors in to the board where it is labelled C1 and C3. Make sure the device is the correct way around. The capacitors have a '-' sign marked on them which should match the same sign on the PCB.

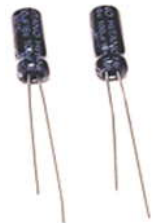

4 CONNECT THE WIRES

The 3 connections to your amplifier PCB need to go through the strain relief holes as shown in the picture. Start with the connection labelled 'Speaker'. The kit is supplied with ½ a metre of twin cable with a 3.5mm Jack connector on one end. This cable will be used to connect both the speaker and the MP3 player. You will need to cut a length from the end that does not have the Jack connector on, which will be used to connect the speaker. Make sure that you leave enough cable so that you have a long enough lead to connect your MP3 player!



Mono Amplifier Essentials

www.kitronik.co.uk/2165



Take the piece of wire that you have cut off and strip the ends of the wire. Connect one end to the two terminals on the speaker and the other end to the board connection marked 'Speaker'. Whilst it doesn't matter which way around the speaker connections go you may wish to connect the stripe to the pad on the board marked stripe and at the speaker end connect the stripe to the '-' terminal.

The middle connection is for the power. The AA battery case (shown left) should be attached to the power connection. Connect the red wire to '+' and the black wire to '-'.



The final connection is the audio input. Strip the insulation off the other end of the remaining cable that has the Jack plug on. Run some solder into the wire and trim the wire so that only 2 or 3mm of bare wire is left. Solder these wires into the board where it is labelled 'Input'. The side of the wire with the stripe should be connected to the pad labelled stripe.

Checking Your Amplifier PCB

Carefully check the following before you insert the batteries:

Audio equipment may become damaged if connected to an incorrectly built amplifier.

Check the bottom of the board to ensure that:

- All holes (except the 4 large (3.3 mm) holes in the corners) are filled with the lead of a component.
- All these leads are soldered.
- Leads next to each other are not soldered together.

Check the top of the board to ensure that:

- The three wires are connected to the right place.
- The '-' on the capacitors match the same marks on the PCB.
- The colour bands on R1 are Brown, Green, Orange & R2 are Brown, Black, Yellow.
- The battery clip red and black wires match the red & black text on the PCB.



Adding an On / Off Switch

If you wish to add a [power switch](#), don't solder both ends of the battery clip directly into the board, instead:

1

Solder the black wire '-' of the battery clip to the PCB.

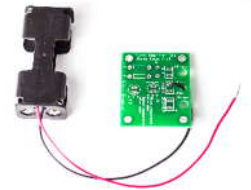

2

Solder the red wire '+' of the battery clip to the on / off switch.

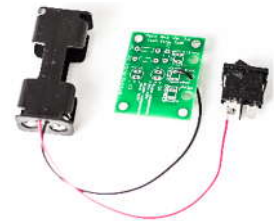

3

Using a piece of red wire, solder the remaining terminal on the on / off switch to the remaining power connection on the PCB.

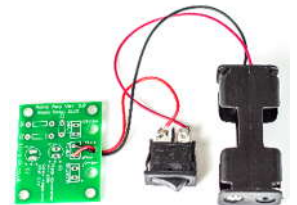

Fault finding flow chart

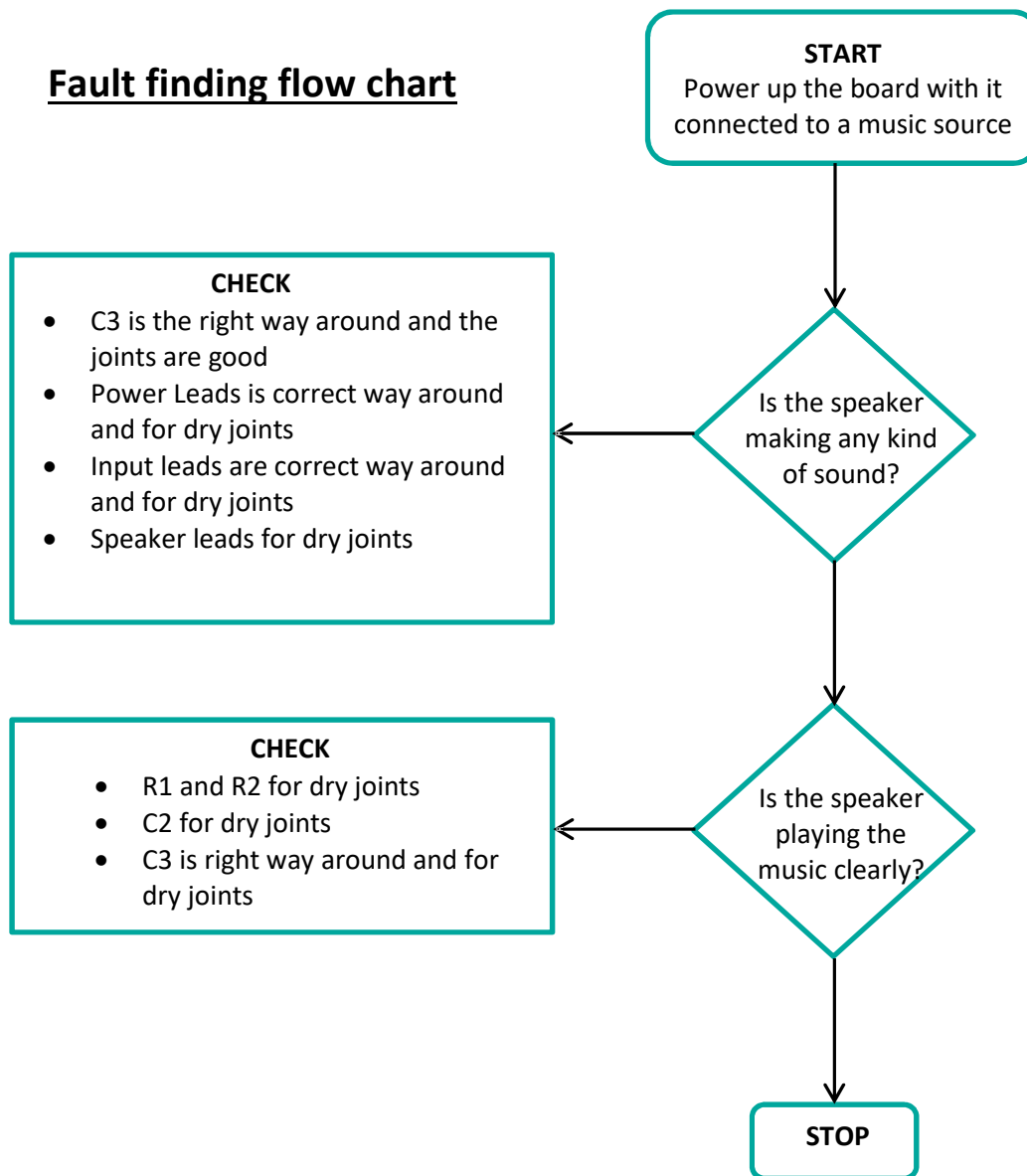

Designing the Enclosure

When you design the enclosure, you will need to consider:

- The size of the PCB (below left, height including components = 15mm)
- How big the batteries are.
- How to mount the speaker (below right).
- How to allow the audio cable out of the box.
- Are you making the amplifier for a particular MP3 player, if so should the MP3 player go in the box?

These technical drawings of the amplifier PCB and speaker should help you plan this.

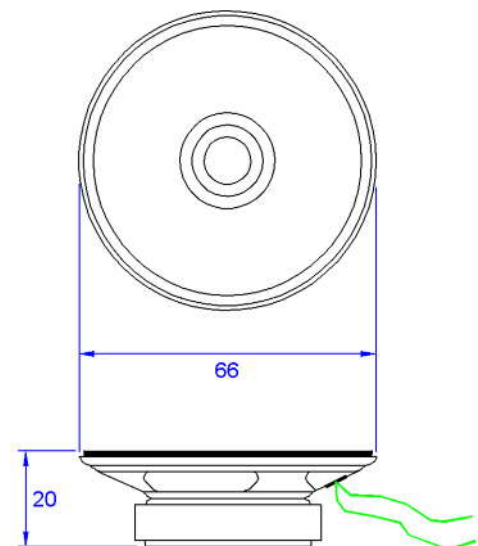
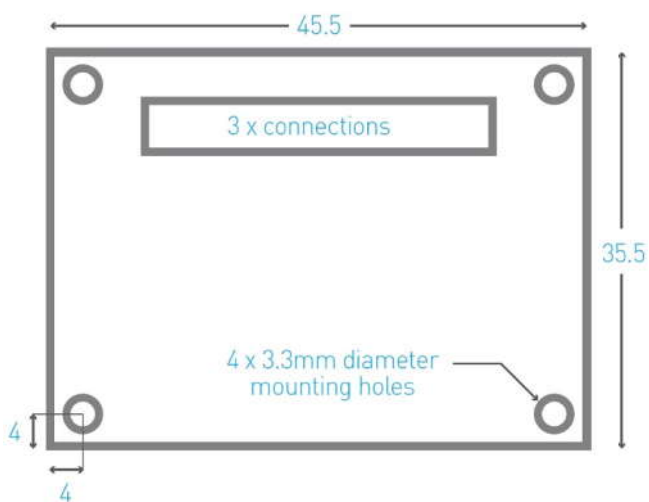

All dimensions in mm
x4 holes 3.3mm diameter

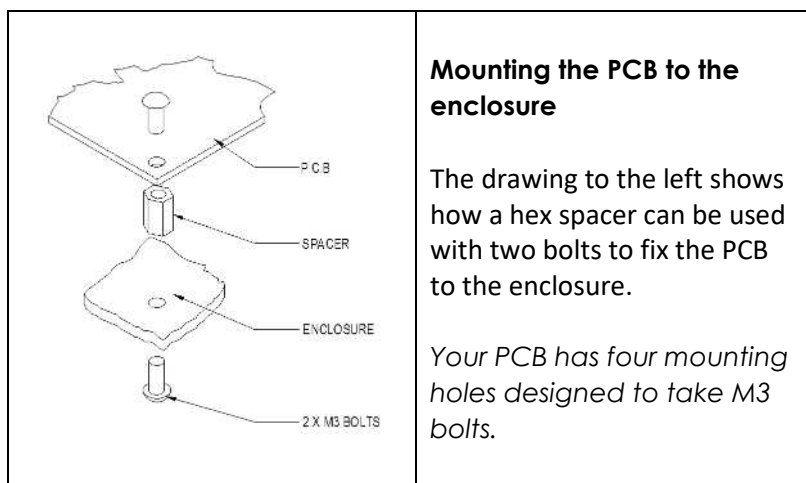

How the Amplifier Works

At the centre of the circuit is an audio amplifier Integrated Circuit or IC. Inside the IC are lots of transistors, which are connected together to allow the small input signal to be amplified into a more powerful output that can drive a speaker.

All amplifiers need to use feedback to ensure the amount of gain stays the same. This allows the output to be an exact copy of the input just bigger. The gain is the number of times bigger the output is compared to the input, so if an amplifier has a gain of 10 and there is 1 volt on the input there will be 10 volts on the output. Before looking at how the feedback works, we first need to understand how a standard amplifier works. An operational amplifier has two inputs these are called the inverting (-) and non-inverting (+) inputs. The output of the operational amplifier is the voltage on the non-inverting input less the voltage on the inverting input multiplied by the amplifiers gain. In theory an operational amplifier has unlimited gain so if the non-inverting input is a fraction higher than the inverting input (there is more + than -) the output will go up to the supply voltage. Change the inputs around and the output will go to zero volts. In this format the operational amplifier is acting as a comparator, it compares the two inputs and changes the output accordingly.

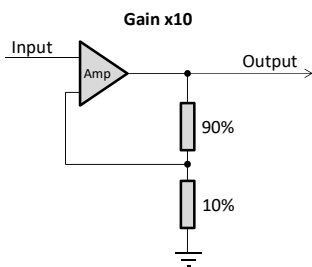

With an infinite gain the amplifier is no good to amplify audio, which is where the feedback comes in. By making one of the inputs a percentage of the output the gain can be fixed, which allows the output to be a copy of the input but bigger. Now when the two inputs are compared and the output is adjusted, instead of it going up or down until it reaches 0 volts or V+, it stops at the point when the two inputs match and the output is at the required voltage.

Looking at the circuit diagram for the audio amplifier, R2 is the feedback resistor. For a standard (single ended) amplifier the gain would be calculated by $R2 / R1$, giving a gain of $100k / 15k = 6.66$. However this amplifier is a differential amplifier, which means the second output is an inverted version of the first output (see diagram below) and results in twice the gain, so the overall gain is 13.33

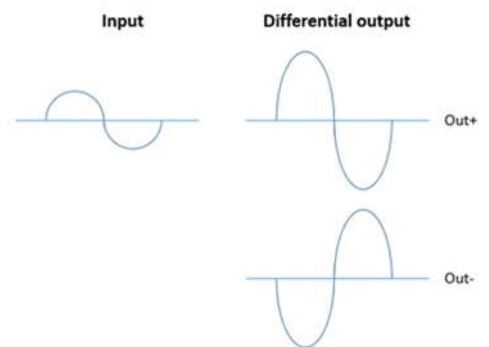
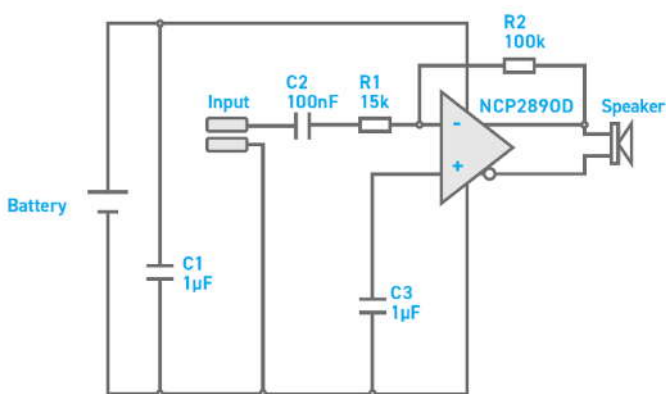

The rest of the components are needed as follows:

C1 is connected across the supply to make sure that it remains stable.

C2 forms a high pass filter, with R1, to block DC voltages which could damage the amplifier.

C3 provides a controlled start to the amplifier, to prevent speaker damage.



Online Information

Two sets of information can be downloaded from the product page where the kit can also be reordered from. The 'Essential Information' contains all of the information that you need to get started with the kit and the 'Teaching Resources' contains more information on soldering, components used in the kit, educational schemes of work and so on and also includes the essentials. Download from:

www.kitronik.co.uk/2165



This kit is designed and manufactured in the UK by Kitronik

Telephone: +44 (0) 845 8380781

Sales email: sales@kitronik.co.uk

Tech support email: support@kitronik.co.uk

Web: www.kitronik.co.uk



www.kitronik.co.uk/twitter



www.kitronik.co.uk/facebook



www.kitronik.co.uk/youtube



www.kitronik.co.uk/google

Every effort has been made to ensure that these notes are correct, however Kitronik accept no responsibility for issues arising from errors / omissions in the notes.

© Kitronik Ltd - Any unauthorised copying / duplication of this booklet or part thereof for purposes except for use with Kitronik project kits is not allowed without Kitronik's prior consent.

