



Chipsmall Limited consists of a professional team with an average of over 10 year of expertise in the distribution of electronic components. Based in Hongkong, we have already established firm and mutual-benefit business relationships with customers from,Europe,America and south Asia,supplying obsolete and hard-to-find components to meet their specific needs.

With the principle of “Quality Parts,Customers Priority,Honest Operation,and Considerate Service”,our business mainly focus on the distribution of electronic components. Line cards we deal with include Microchip,ALPS,ROHM,Xilinx,Pulse,ON,Everlight and Freescale. Main products comprise IC,Modules,Potentiometer,IC Socket,Relay,Connector.Our parts cover such applications as commercial,industrial, and automotives areas.

We are looking forward to setting up business relationship with you and hope to provide you with the best service and solution. Let us make a better world for our industry!



Contact us

Tel: +86-755-8981 8866 Fax: +86-755-8427 6832

Email & Skype: info@chipsmall.com Web: www.chipsmall.com

Address: A1208, Overseas Decoration Building, #122 Zhenhua RD., Futian, Shenzhen, China



4

3

2

1

THIS DRAWING IS UNPUBLISHED. RELEASED FOR PUBLICATION 20
 © COPYRIGHT 20 BY - ALL RIGHTS RESERVED.

LOC	DIST	REVISIONS					
GP	00	P	LTR	DESCRIPTION	DATE	DWN	APVD
		B		REVISED PER ECO-12-021786	04MAR2013	CJV	MRS

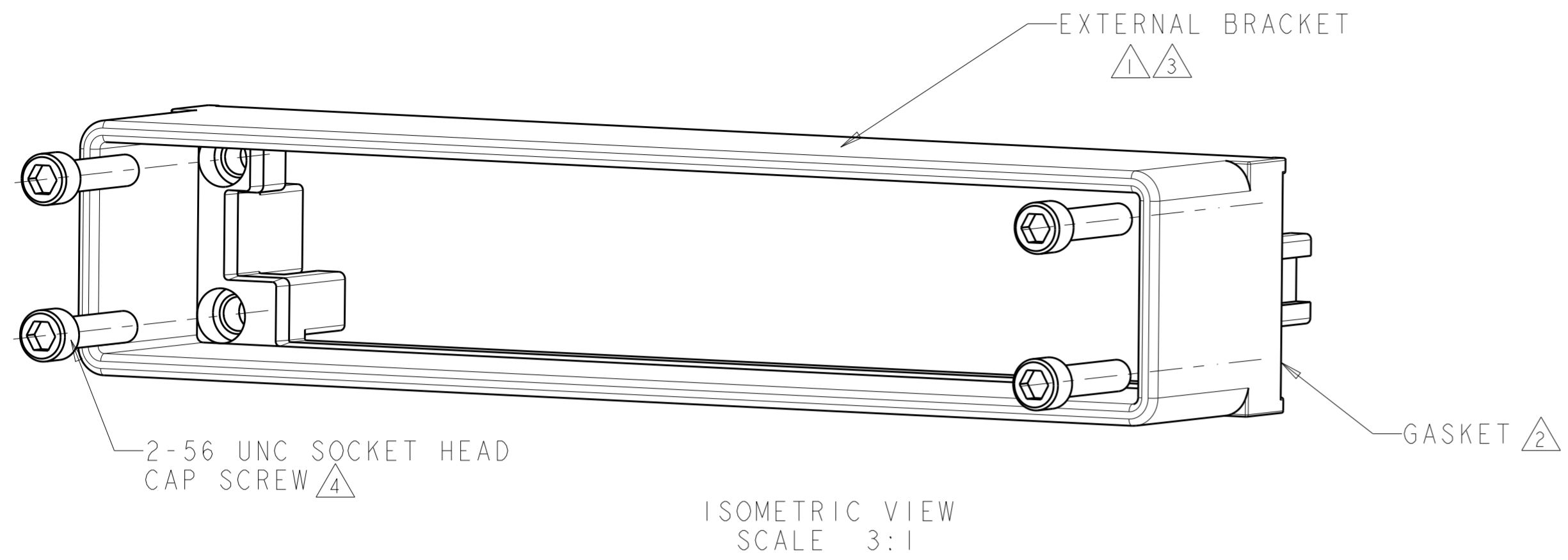

- ① MATERIAL: ZINC ALLOY PER ASTM B 86. ALLOY AG40A.
- ② MATERIAL: CHOMERICS CHO-SEAL 1270, SILVER PLATED COPPER IN SILICONE.
- ③ FINISH: 1.27µm MIN NICKEL PLATE PER QQ-N-290 OVER 5.08µm MIN COPPER PLATE PER AMS 2418.
- ④ MATERIAL: STAINLESS STEEL

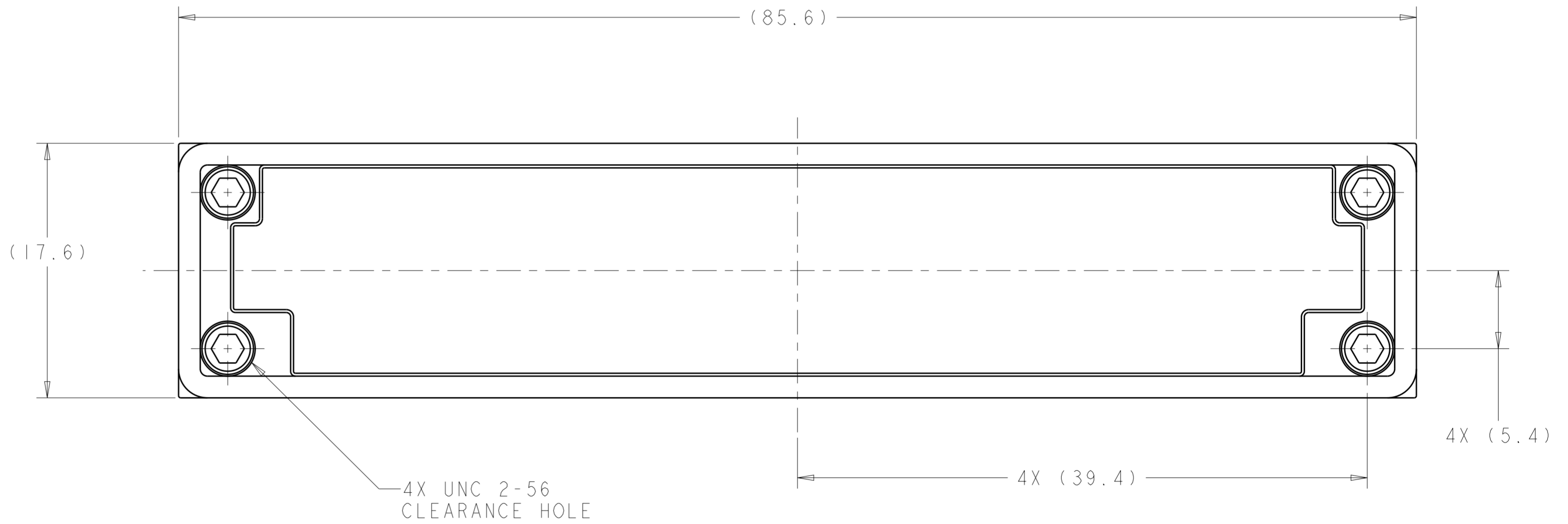
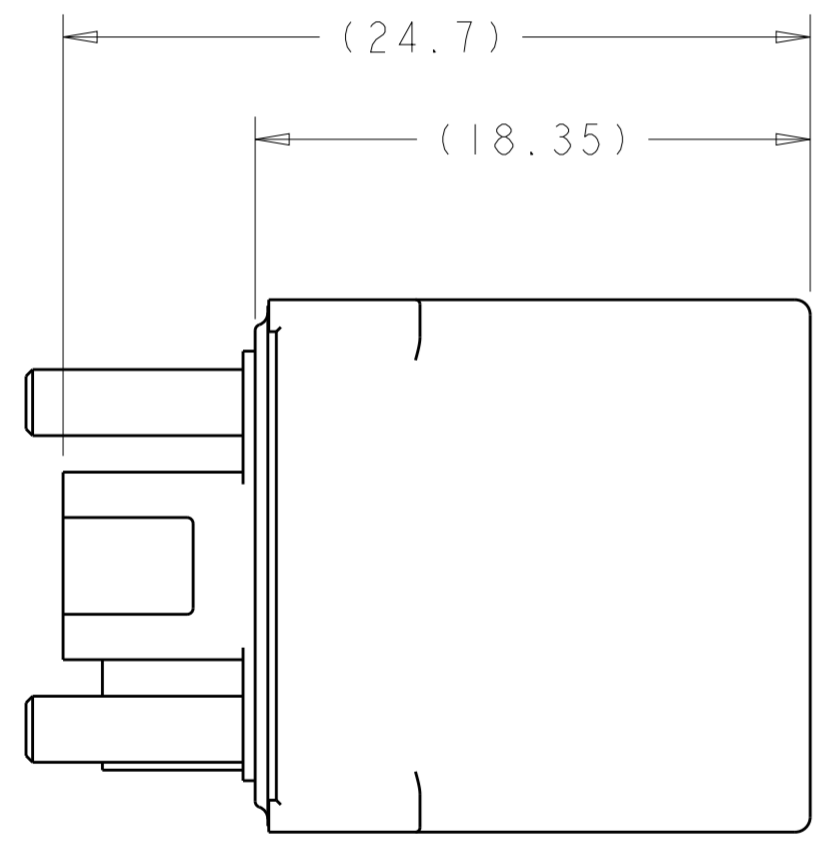

2169710-1
PART NUMBER

THIS DRAWING IS A CONTROLLED DOCUMENT. DIMENSIONING AND TOLERANCING PER ASME Y14.5M-2009		DWN B. MATTHEWS 22DEC2010	STE TE Connectivity
DIMENSIONS: mm		CHK M. SCHMITT 22DEC2010	
TOLERANCES UNLESS OTHERWISE SPECIFIED:		APVD M. SCHMITT 22DEC2010	NAME EXTERNAL BRACKET ASSEMBLY KIT, CFP PLUGGABLE
0 PLC ±	1 PLC ±	PRODUCT SPEC 108-2399	SIZE A200779
2 PLC ±	3 PLC ±	APPLICATION SPEC 114-13263	CAGE CODE C-2169710
4 PLC ±	ANGLES ±	WEIGHT -	DRAWING NO -
MATERIAL -	FINISH -	CUSTOMER DRAWING	RESTRICTED TO -
SCALE 4:1			SHEET 1 OF 1 REV B