



Chipsmall Limited consists of a professional team with an average of over 10 year of expertise in the distribution of electronic components. Based in Hongkong, we have already established firm and mutual-benefit business relationships with customers from,Europe,America and south Asia,supplying obsolete and hard-to-find components to meet their specific needs.

With the principle of "Quality Parts,Customers Priority,Honest Operation,and Considerate Service",our business mainly focus on the distribution of electronic components. Line cards we deal with include Microchip,ALPS,ROHM,Xilinx,Pulse,ON,Everlight and Freescale. Main products comprise IC,Modules,Potentiometer,IC Socket,Relay,Connector.Our parts cover such applications as commercial,industrial, and automotives areas.

We are looking forward to setting up business relationship with you and hope to provide you with the best service and solution. Let us make a better world for our industry!



## Contact us

Tel: +86-755-8981 8866 Fax: +86-755-8427 6832

Email & Skype: [info@chipsmall.com](mailto:info@chipsmall.com) Web: [www.chipsmall.com](http://www.chipsmall.com)

Address: A1208, Overseas Decoration Building, #122 Zhenhua RD., Futian, Shenzhen, China



THIS DRAWING IS UNPUBLISHED.

RELEASED FOR PUBLICATION

20

© COPYRIGHT 20 TE CONNECTIVITY

ALL RIGHTS RESERVED.

LOC GP DIST 00

REVISIONS

P	LTR	DESCRIPTION	DATE	DWN	APVD
	1	DRAFT	30AUG2012	LW	SY

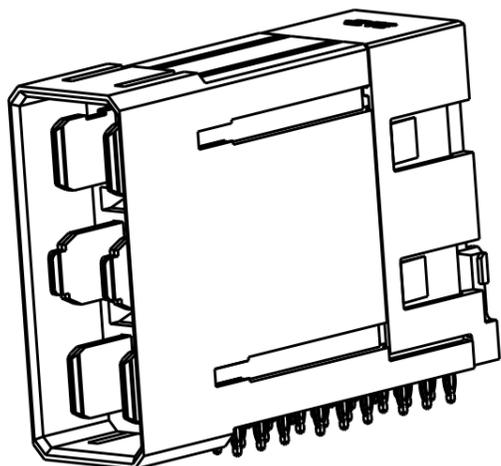

NOTES:

1. MATERIALS:  
 HOUSING: HIGH TEMP. THERMOPLASTIC GLASS/MINERAL FILLED UL94V-0  
 TERMINAL: COPPER ALLOY

2. FINISH:  
 TIN OPTION-0.76um MIN GOLD AT CONTACT AREA AND  
 1.27um MIN NICKEL UNDERPLATED OVER ALL  
 2.54um TIN AT SOLDER TAIL AREA  
 TIN-LEAD OPTION-0.76um MIN GOLD AT CONTACT AREA AND  
 1.27um MIN NICKEL UNDERPLATED OVER ALL  
 2.54um TIN-LEAD AT SOLDER TAIL AREA

3. REFER TO TE'S PRODUCT SPECIFICATION: 108-2473  
 FOR PLATED THROUGH-HOLE SPECIFICATION AND TORQUE FORCE

4. CONNECTOR WERE PACKED BY TRAY  
 REFER TO TE'S PACKAGING SPECIFICATION: 107-\*\*\*

5. MATED WITH \*-2169862-\*

6. LASER MARK PART NUMBER AND DATE CODE (YYWWDS)  
 CAN BE AT THE OPPOSITE SIDE

7. KEEP OUT ZONE FROM OTHER COMPONENT

PACKAGING	PLATING TYP	P3	P2	P1	PART NUMBER
TRAY	NIT	6.90	6.90	5.70	2169872-8
		5.70	5.70	6.90	2169872-7
		6.90	5.70	5.70	2169872-6
		6.90	6.90	6.90	2169872-5
		6.90	6.90	5.70	2169872-4
		5.70	5.70	6.90	2169872-3
		6.90	5.70	5.70	2169872-2
		6.90	6.90	6.90	2169872-1

THIS PRINT IS  
**PRELIMINARY**  
 UNQUALIFIED PRODUCT  
 CONTACT PRODUCT ENGINEERING  
 BEFORE USING THIS PRINT

THIS DRAWING IS A CONTROLLED DOCUMENT.		DWN L. WANG 30AUG2012		
DIMENSIONS: mm		CHK S. YAN 30AUG2012		
TOLERANCES UNLESS OTHERWISE SPECIFIED:		APVD A. CAI 30AUG2012	NAME	
0 PLC ±--		PRODUCT SPEC 108-2473	IMPACT POWER 6 PAIR	
1 PLC ±--		APPLICATION SPEC 114-32028	RIGHT ANGLE HEADER	
2 PLC ±0.25		WEIGHT -	PRESS-FIT	
3 PLC ±--		Customer Drawing	SIZE A3	CAGE CODE 00779
4 PLC ±--		SCALE 1:1	DRAWING NO C-2169872	RESTRICTED TO -
ANGLES ±3°		SHEET 1 OF 3	REV 1	
FINISH				

THIS DRAWING IS UNPUBLISHED. RELEASED FOR PUBLICATION 20  
 © COPYRIGHT 20 TE CONNECTIVITY ALL RIGHTS RESERVED.

LOC	DIST	REVISIONS			
P	LTR	DESCRIPTION	DATE	DWN	APVD
GP	00	-	SEE SHEET 1	-	-

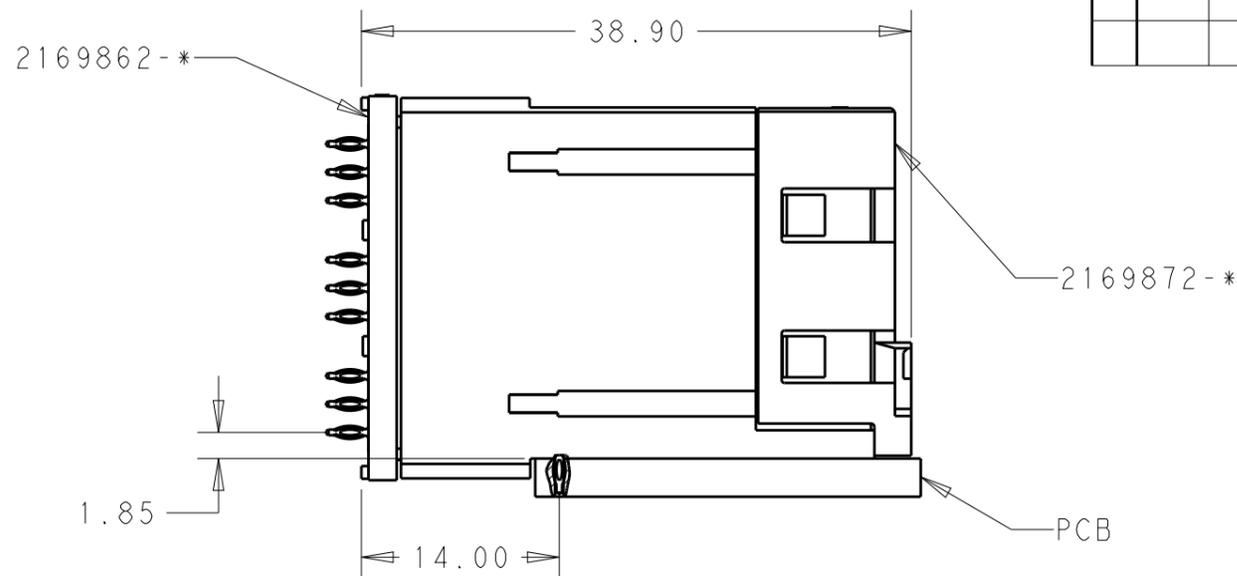
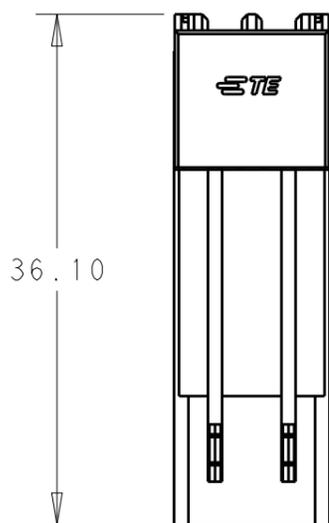

MATED SYSTEM WITH 2169872

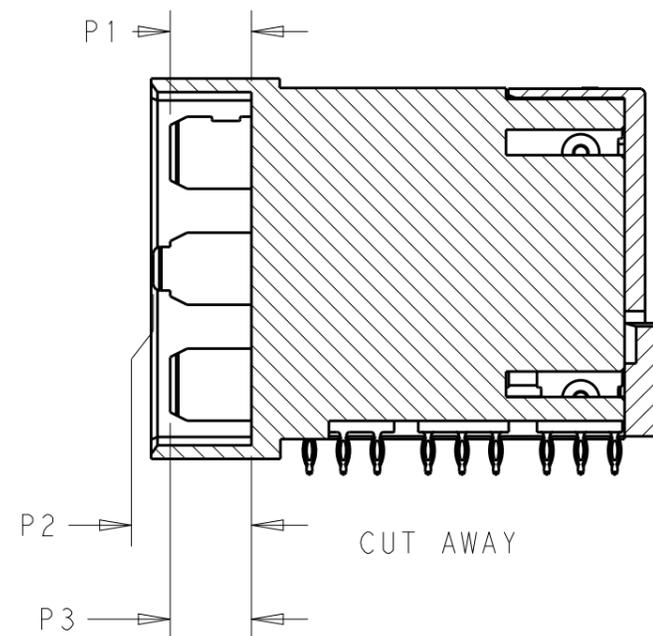
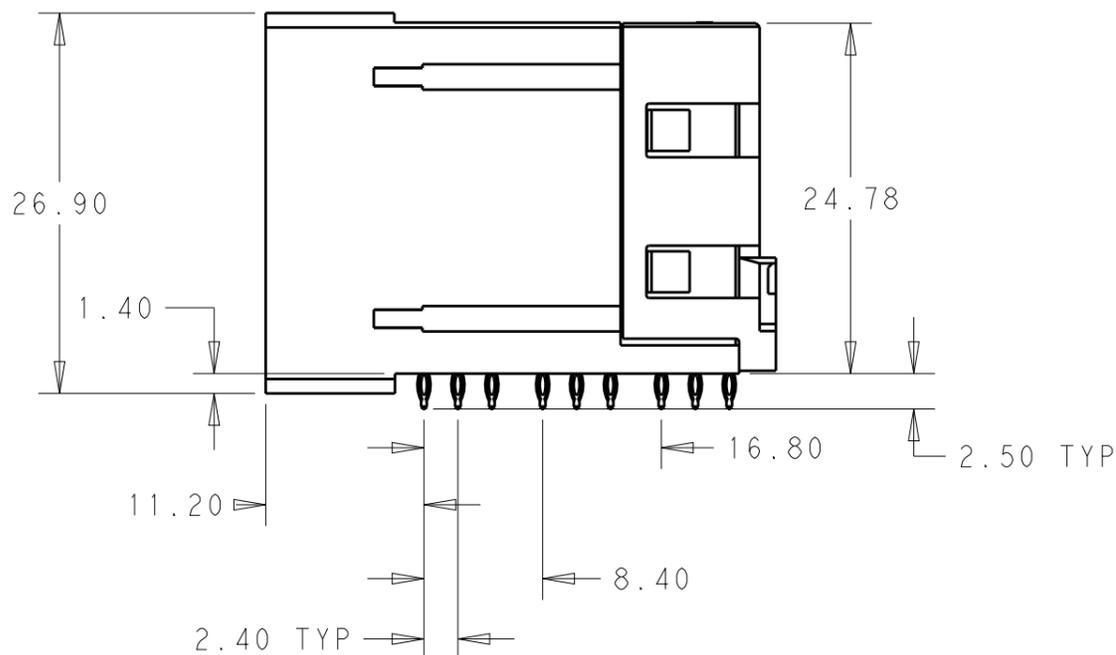
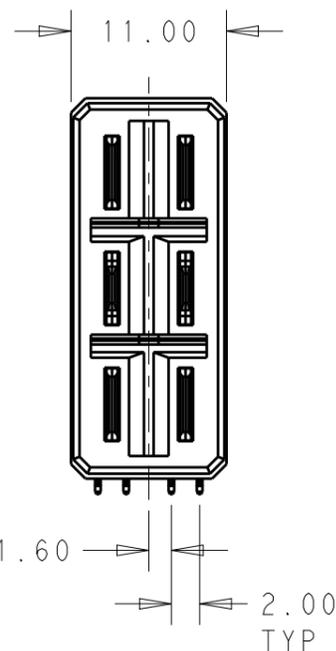

THIS DRAWING IS A CONTROLLED DOCUMENT.		DWN L. WANG 30AUG2012	 TE Connectivity	NAME IMPACT POWER 6 PAIR RIGHT ANGLE HEADER PRESS-FIT
DIMENSIONS: mm		CHK S. YAN 30AUG2012		
TOLERANCES UNLESS OTHERWISE SPECIFIED:		APVD A. CAI 30AUG2012		
0 PLC ±-- 1 PLC ±-- 2 PLC ±0.25 3 PLC ±-- 4 PLC ±-- ANGLES ±3°		PRODUCT SPEC 108-2473		
MATERIAL		APPLICATION SPEC 114-32028	SIZE A3	CAGE CODE 00779
FINISH		WEIGHT -	DRAWING NO C-2169872	RESTRICTED TO -
Customer Drawing			SCALE 1:1	SHEET 2 OF 3
			REV 1	

4

3

2

1

THIS DRAWING IS UNPUBLISHED.

RELEASED FOR PUBLICATION

20

© COPYRIGHT 20

TE CONNECTIVITY

ALL RIGHTS RESERVED.

LOC  
GPDIST  
00

REVISIONS

P	LTR	DESCRIPTION	DATE	DWN	APVD
-	-	SEE SHEET 1	-	-	-

CONNECTOR WITH PCB

RECOMMENDED PCB LAYOUT  
(COMPONENT SIDE SHOWN)  
MINIMUM BOARD THICKNESS: 1.60MM

THIS DRAWING IS A CONTROLLED DOCUMENT.

DWN 30AUG2012

L. WANG

CHK 30AUG2012

S. YAN

APVD 30AUG2012

A. CAI

PRODUCT SPEC

108-2473

APPLICATION SPEC

114-32028

WEIGHT

-

Customer Drawing

TE Connectivity

NAME

IMPACT POWER 6 PAIR  
RIGHT ANGLE HEADER  
PRESS-FIT

SIZE

CAGE CODE

DRAWING NO

RESTRICTED TO

A3

00779

C-2169872

-

DIMENSIONS:

mm

TOLERANCES UNLESS OTHERWISE SPECIFIED:

0 PLC	±--
1 PLC	±--
2 PLC	±0.25
3 PLC	±--
4 PLC	±--
ANGLES	±3°

MATERIAL

FINISH

1470-19 (3/11)