



Chipsmall Limited consists of a professional team with an average of over 10 year of expertise in the distribution of electronic components. Based in Hongkong, we have already established firm and mutual-benefit business relationships with customers from,Europe,America and south Asia,supplying obsolete and hard-to-find components to meet their specific needs.

With the principle of “Quality Parts,Customers Priority,Honest Operation,and Considerate Service”,our business mainly focus on the distribution of electronic components. Line cards we deal with include Microchip,ALPS,ROHM,Xilinx,Pulse,ON,Everlight and Freescale. Main products comprise IC,Modules,Potentiometer,IC Socket,Relay,Connector.Our parts cover such applications as commercial,industrial, and automotives areas.

We are looking forward to setting up business relationship with you and hope to provide you with the best service and solution. Let us make a better world for our industry!



## Contact us

Tel: +86-755-8981 8866 Fax: +86-755-8427 6832

Email & Skype: info@chipsmall.com Web: www.chipsmall.com

Address: A1208, Overseas Decoration Building, #122 Zhenhua RD., Futian, Shenzhen, China



THIS DRAWING IS UNPUBLISHED. RELEASED FOR PUBLICATION 20  
 © COPYRIGHT 20 BY - ALL RIGHTS RESERVED.

| REVISIONS |     |             |           |       |
|-----------|-----|-------------|-----------|-------|
| P         | LTR | DESCRIPTION | DATE      | APVD  |
|           | A   | RELEASE     | 01NOV2016 | JY SH |
|           |     |             |           |       |
|           |     |             |           |       |

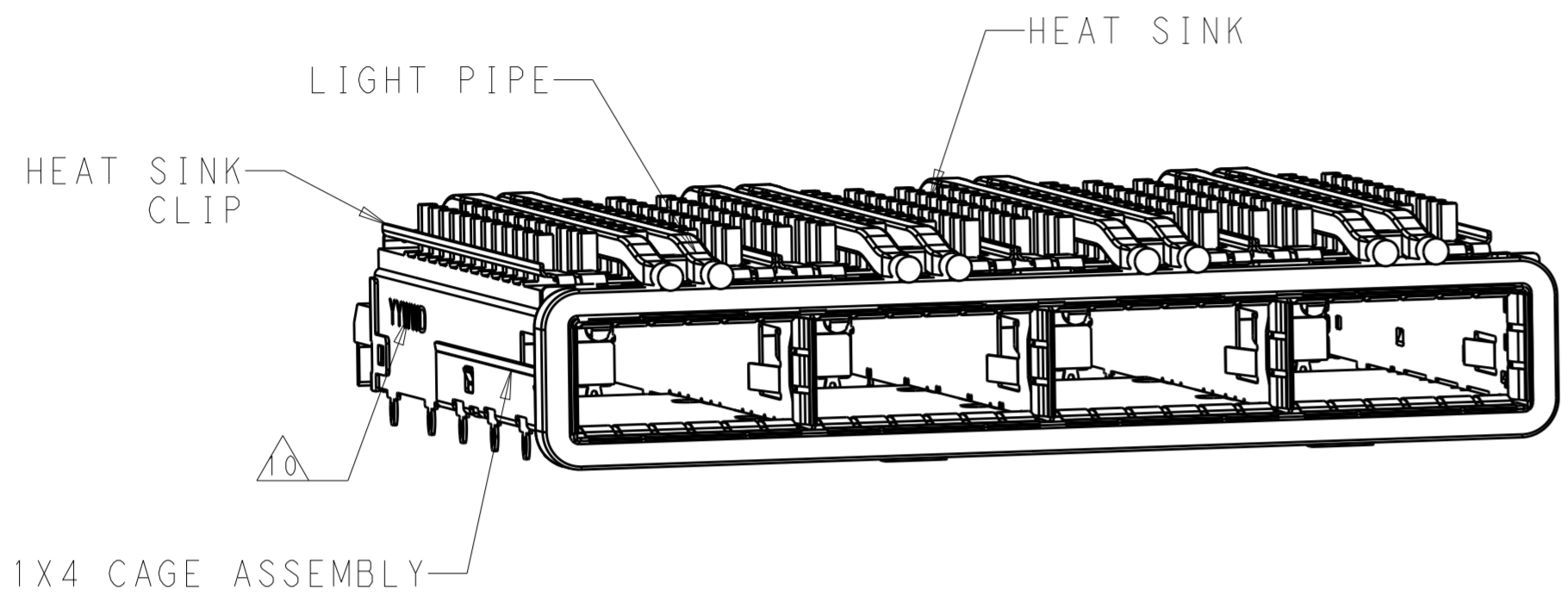

1. COMPONENTS  
 CAGE ASSEMBLY: NICKEL-SILVER ALLOY  
 HEAT SINK: ALUMINUM/BLACK ANODIZE  
 HEAT SINK CLIP: STAINLESS STEEL  
 EMI SPRING: COPPER ALLOY/NICKEL PLATE  
 EMI GASKET: PLATED FILLED SILICONE  
 LIGHT PIPE: CLEAR POLYCARBONATE WITH 94 V-0  
 ORGANIZER: POLYESTER WITH UL 94 V-0
2. REFERENCE APPLICATION SPECIFICATION 114-32023 FOR RECOMMENDED DRILL HOLE DIAMETER AND PLATING THICKNESS
3. DATUM AND BASIC DIMENSION ESTABLISHED BY CUSTOMER
4. DIMENSION APPLIES WITH MODULE INSERTED IN CAGE
5. HEAT SINKS, HEAT SINK CLIPS AND LIGHT PIPES ARE SHIPPED ASSEMBLED ON CAGE
6. MINIMUM PC BOARD THICKNESS: SINGLE SIDED: 1.57 MIN  
 DOUBLE SIDED: 3.00 MIN
7. DATUM -A- IS TOP SURFACE OF THE HOST BOARD.
8. THESE HOLES ARE OPTIONAL WHEN THE REAR PINS ARE REMOVED.
9. MATES WITH QSFP28 MSA COMPATIBLE TRANSCEIVER.
10. DATE CODE (YYWWD) MARKED APPROXIMATELY AS SHOWN.

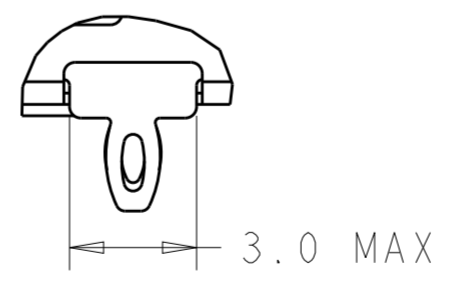
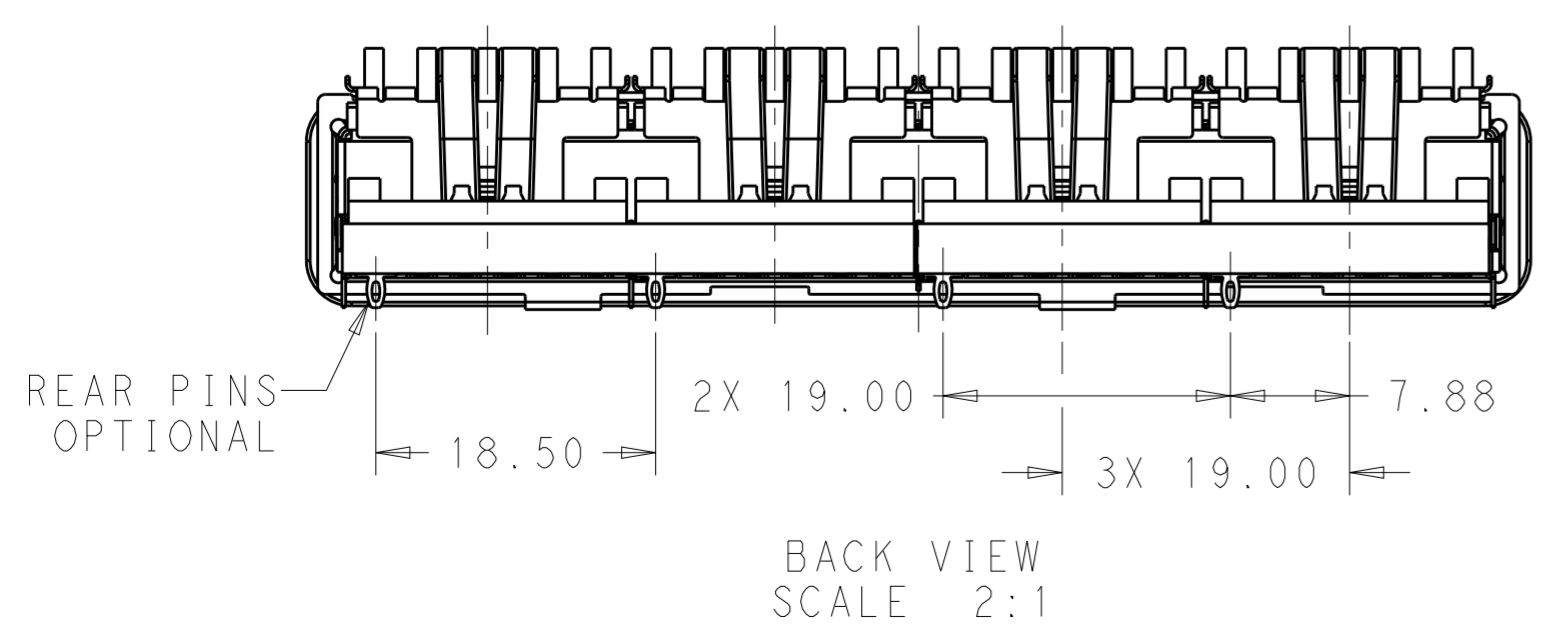
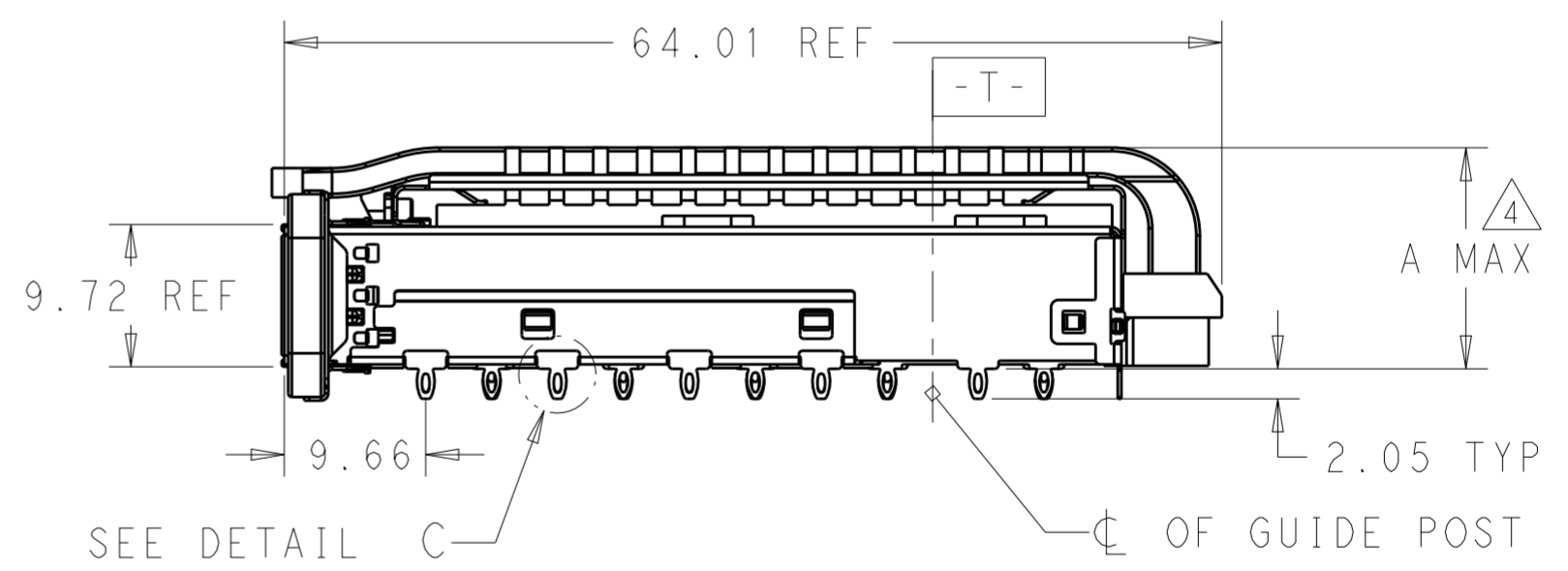
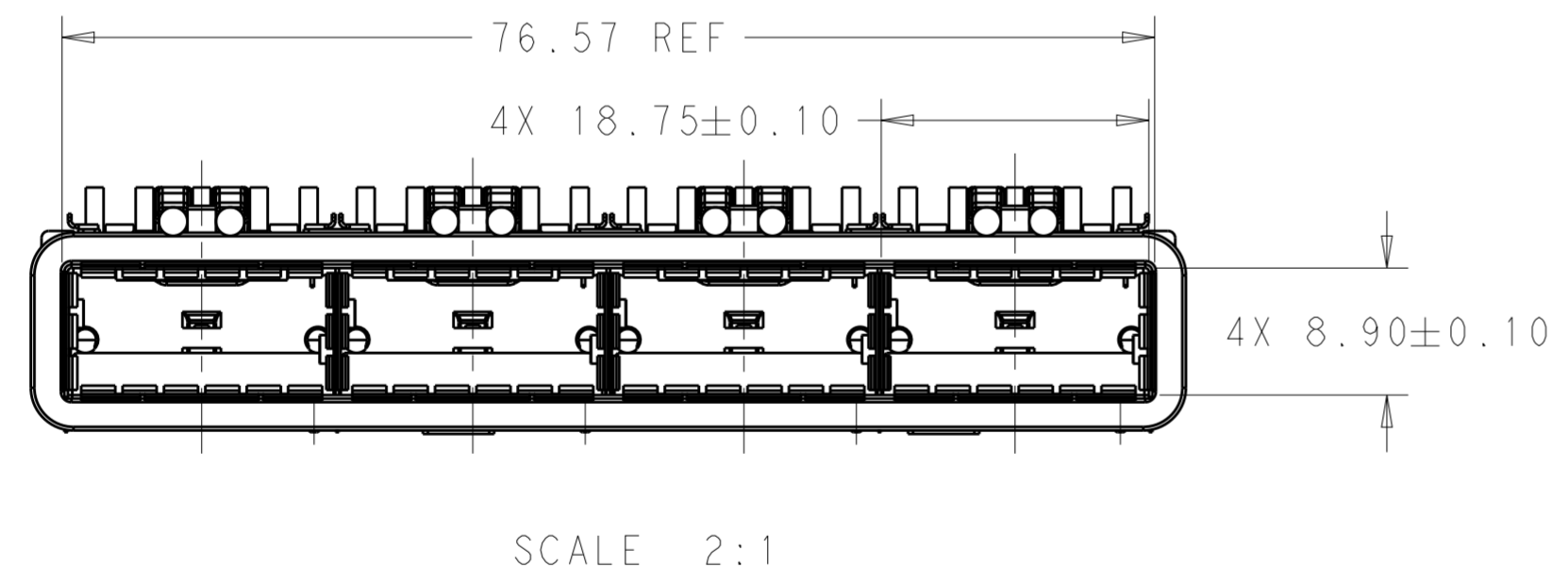

DETAIL C  
 SCALE 6:1

|  |  |                               |                 |   |
|--|--|-------------------------------|-----------------|---|
| THIS DRAWING IS A CONTROLLED DOCUMENT. |  | DWN 20 JUN 2014<br>JASON YANG | TE Connectivity |   |
|  |  | CHK 01 NOV 2016<br>SEAN HAN   |                 |   |
| DIMENSIONS: mm                         |  | APVD -                        |                 | NAME  |
| TOLERANCES UNLESS OTHERWISE SPECIFIED: |  | PRODUCT SPEC                  |                 | RECEPTACLE CAGE ASSEMBLY WITH HEAT SINKS AND LIGHT PIPES, THRU BEZEL, 1X4, QSFP28, GASKET |
| 0 PLC ±                                |  | 108-19428                     |                 | SIZE  |
| 1 PLC ±0.25                            |  | APPLICATION SPEC              |                 | A200779   |
| 2 PLC ±0.2                             |  | 114-32023                     |                 | CAGE CODE   |
| 3 PLC ±                                |  | WEIGHT -                      |                 | DRAWING NO  |
| 4 PLC ±                                |  | CUSTOMER DRAWING              |                 | C-2170785   |
| ANGLES ±                               |  | SCALE 3:1                     |                 | RESTRICTED TO   |
| FINISH -                               |  | SHEET 1 OF 9                  |                 | REV A   |

| REVISIONS |     |             |      |     |      |
|-----------|-----|-------------|------|-----|------|
| P         | LTR | DESCRIPTION | DATE | DWN | APVD |
| -         |     | SEE SHEET 1 | -    | -   | -    |
|           |     |             |      |     |      |
|           |     |             |      |     |      |

# HEAT SINK OPTION

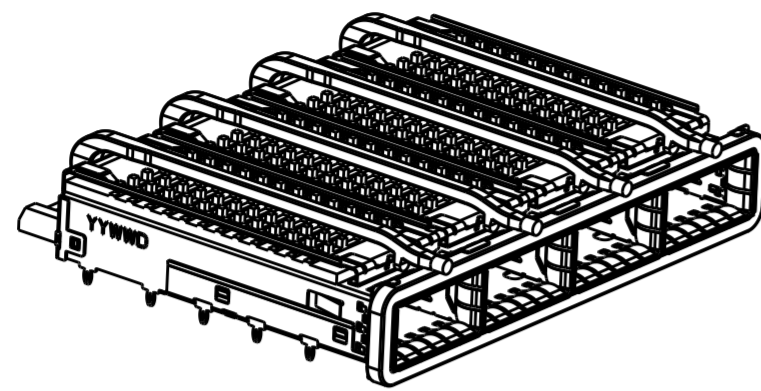

PCI HEAT SINK  
SCALE 1:1

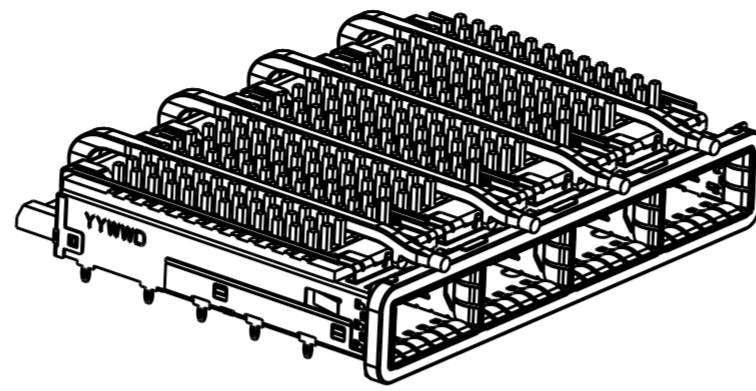

SAN HEAT SINK  
SCALE 1:1

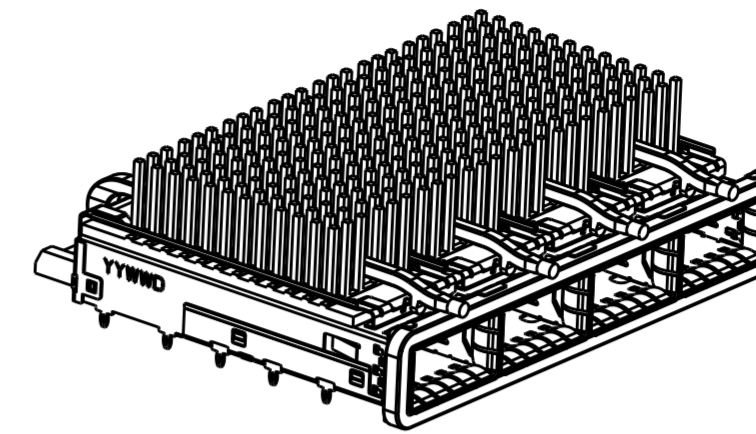

NETWORKING HEAT SINK  
SCALE 1:1

# LIGHT PIPE OPTION

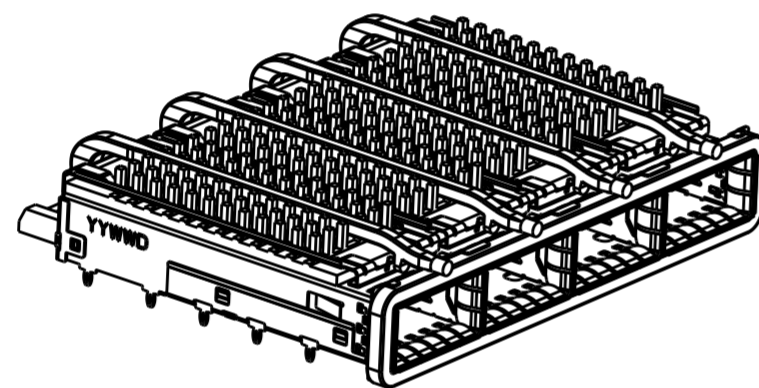

SINGLE LOGHT PIPE  
SCALE 1:1

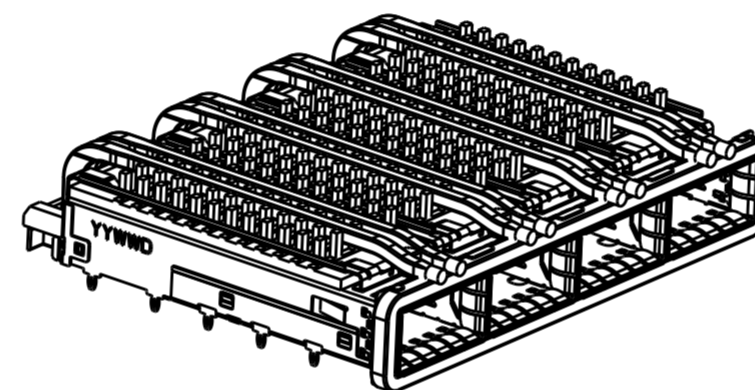

DUAL LIGHT PIPE  
SCALE 1:1

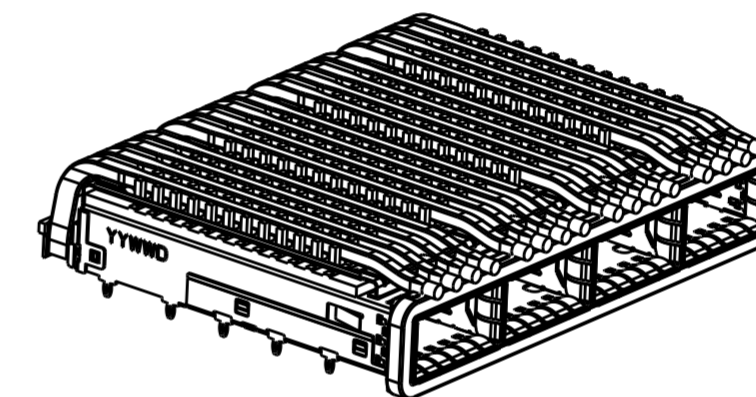

QUAD LIGHT PIPE  
SCALE 1:1

# # OF REAR PIN OPTION

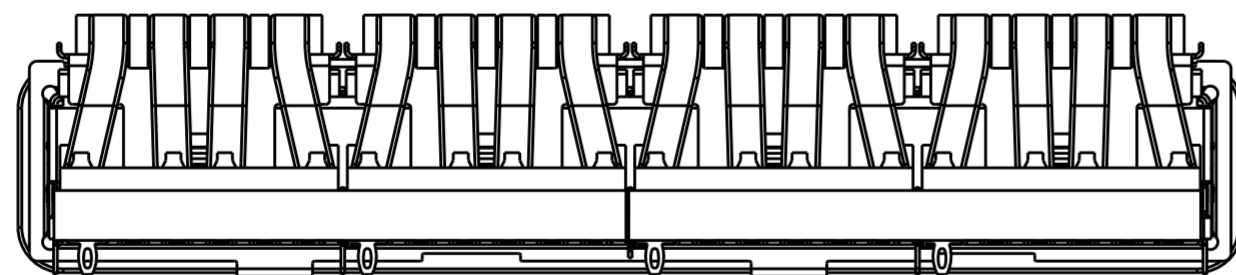

1 REAR PIN  
SCALE 2:1

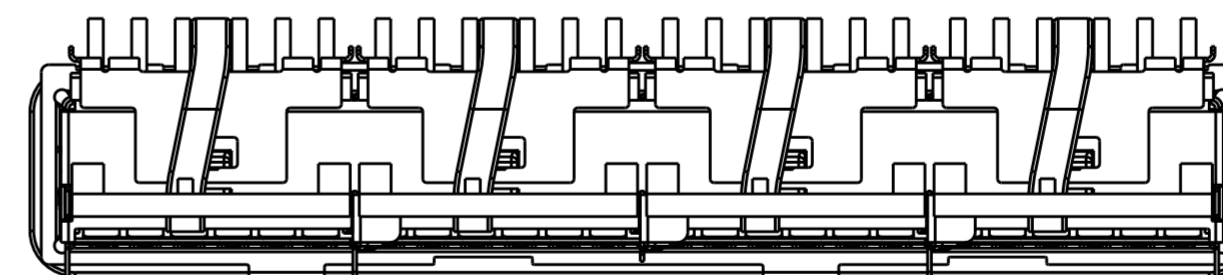

0 REAR PIN  
SCALE 2:1

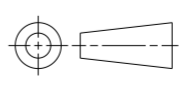
|   |  |                                  |   |  |
|---|--|----------------------------------|---|--|
| THIS DRAWING IS A CONTROLLED DOCUMENT.  |  | DWN<br>JASON YANG<br>20 JUN 2014 |  TE Connectivity |  |
|   |  | CHK<br>SEAN HAN<br>01 NOV 2016   |   |  |
| DIMENSIONS:<br>mm   | TOLERANCES UNLESS OTHERWISE SPECIFIED:   | APVD<br>-                        | NAME<br>RECEPTACLE CAGE ASSEMBLY WITH HEAT SINKS AND LIGHT PIPES, THRU BEZEL, 1X4, QSFP28, GASKET     | RESTRICTED TO                                  |
|  | 0 PLC ±<br>1 PLC ±0.25<br>2 PLC ±0.2<br>3 PLC ±<br>4 PLC ±<br>ANGLES ±<br>FINISH | PRODUCT SPEC<br>108-19428        | SIZE<br>114-32023   | SIZE CAGE CODE DRAWING NO<br>A200779 C-2170785 |
| MATERIAL<br>SEE NOTES   | SEE NOTES  | WEIGHT<br>-                      | CUSTOMER DRAWING  | SCALE 3:1 SHEET 2 OF 9 REV A                   |

THIS DRAWING IS UNPUBLISHED. RELEASED FOR PUBLICATION 20  
 © COPYRIGHT 20 BY - ALL RIGHTS RESERVED.

| REVISIONS |     |             |      |      |
|-----------|-----|-------------|------|------|
| P         | LTR | DESCRIPTION | DATE | APVD |
| -         |     | SEE SHEET 1 | -    | -    |
|           |     |             |      |      |
|           |     |             |      |      |

|               |       |             |                   |             |
|---------------|-------|-------------|-------------------|-------------|
| 0             | 23.0  | NETWORKING  | QUAD              | 4-2170785-6 |
| 0             | 16.0  | SAN         | QUAD              | 4-2170785-5 |
| 0             | 13.7  | PCI         | QUAD              | 4-2170785-4 |
| 1             | 23.0  | NETWORKING  | QUAD              | 4-2170785-3 |
| 1             | 16.0  | SAN         | QUAD              | 4-2170785-2 |
| 1             | 13.7  | PCI         | QUAD              | 4-2170785-1 |
| 0             | 23.0  | NETWORKING  | DUAL              | 2-2170785-6 |
| 0             | 16.0  | SAN         | DUAL              | 2-2170785-5 |
| 0             | 13.7  | PCI         | DUAL              | 2-2170785-4 |
| 1             | 23.0  | NETWORKING  | DUAL              | 2-2170785-3 |
| 1             | 16.0  | SAN         | DUAL              | 2-2170785-2 |
| 1             | 13.7  | PCI         | DUAL              | 2-2170785-1 |
| 0             | 23.0  | NETWORKING  | SINGLE            | 2170785-6   |
| 0             | 16.0  | SAN         | SINGLE            | 2170785-5   |
| 0             | 13.7  | PCI         | SINGLE            | 2170785-4   |
| 1             | 23.0  | NETWORKING  | SINGLE            | 2170785-3   |
| 1             | 16.0  | SAN         | SINGLE            | 2170785-2   |
| 1             | 13.7  | PCI         | SINGLE            | 2170785-1   |
| # OF REAR PIN | DIM A | APPLICATION | LIGHT PIPE OPTION | PART NUMBER |

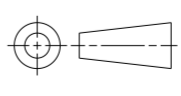
|   |           |  |   |   |
|---|-----------|--|---|---|
| THIS DRAWING IS A CONTROLLED DOCUMENT.  |           | DWN 20 JUN 2014<br>JASON YANG  |  TE Connectivity |   |
|   |           | CHK 01 NOV 2016<br>SEAN HAN  |   |   |
| DIMENSIONS:<br>mm   |           | TOLERANCES UNLESS OTHERWISE SPECIFIED:   |   | NAME  |
|  |           | 0 PLC ±<br>1 PLC ±0.25<br>2 PLC ±0.2<br>3 PLC ±<br>4 PLC ±<br>ANGLES ±<br>FINISH |   | RECEPTACLE CAGE ASSEMBLY WITH HEAT SINKS AND LIGHT PIPES, THRU BEZEL, 1X4, QSFP28, GASKET |
| MATERIAL  | SEE NOTES | PRODUCT SPEC   | 108-19428   | SIZE  |
|   |           | APPLICATION SPEC   | 114-32023   | CAGE CODE   |
|   |           | WEIGHT   | -   | DRAWING NO  |
|   |           | CUSTOMER DRAWING   |   | A200779   |
|   |           | SCALE  | 3:1   | DRAWING NO  |
|   |           | SHEET  | 3 OF 9  | RESTRICTED TO   |
|   |           | REV  | A   |   |

THIS DRAWING IS UNPUBLISHED. RELEASED FOR PUBLICATION 20  
 © COPYRIGHT 20 BY - ALL RIGHTS RESERVED.

| REVISIONS |     |             |      |      |
|-----------|-----|-------------|------|------|
| P         | LTR | DESCRIPTION | DATE | APVD |
| -         | -   | SEE SHEET 1 | -    | -    |
|           |     |             |      |      |
|           |     |             |      |      |

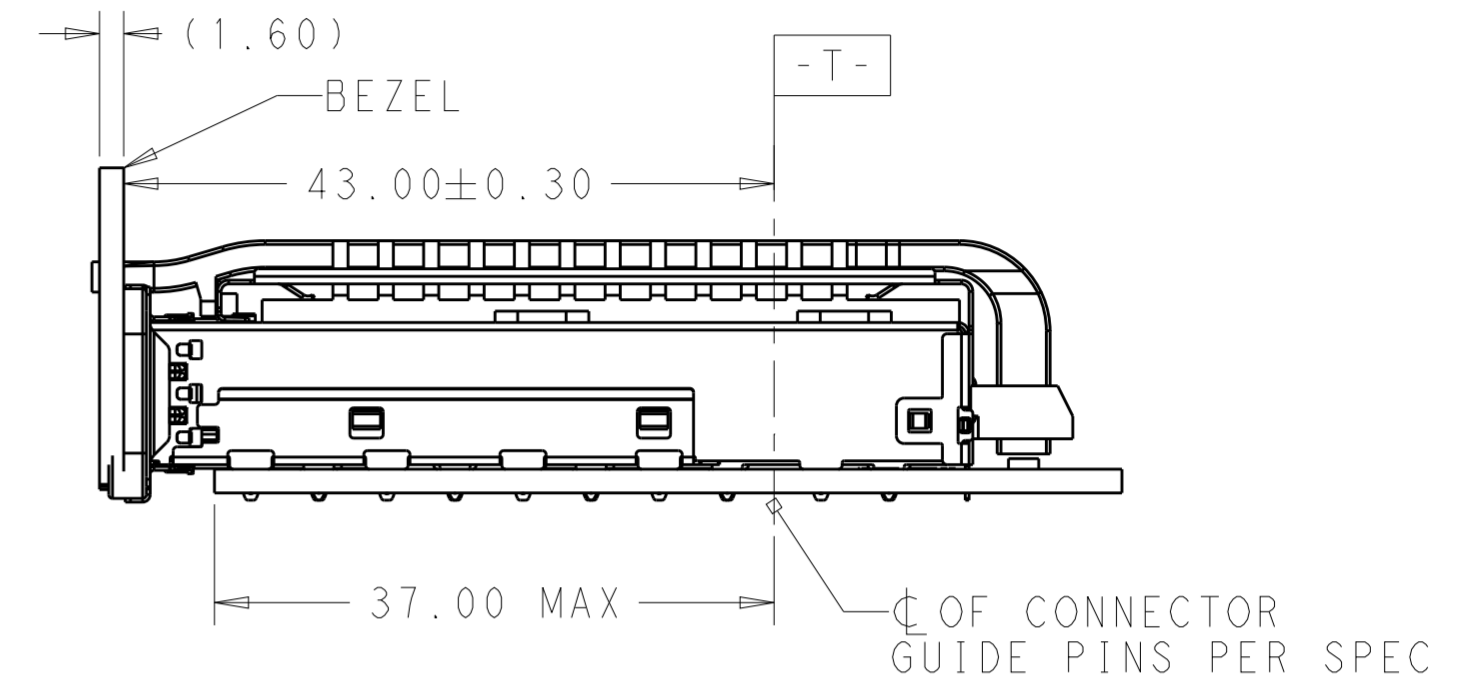
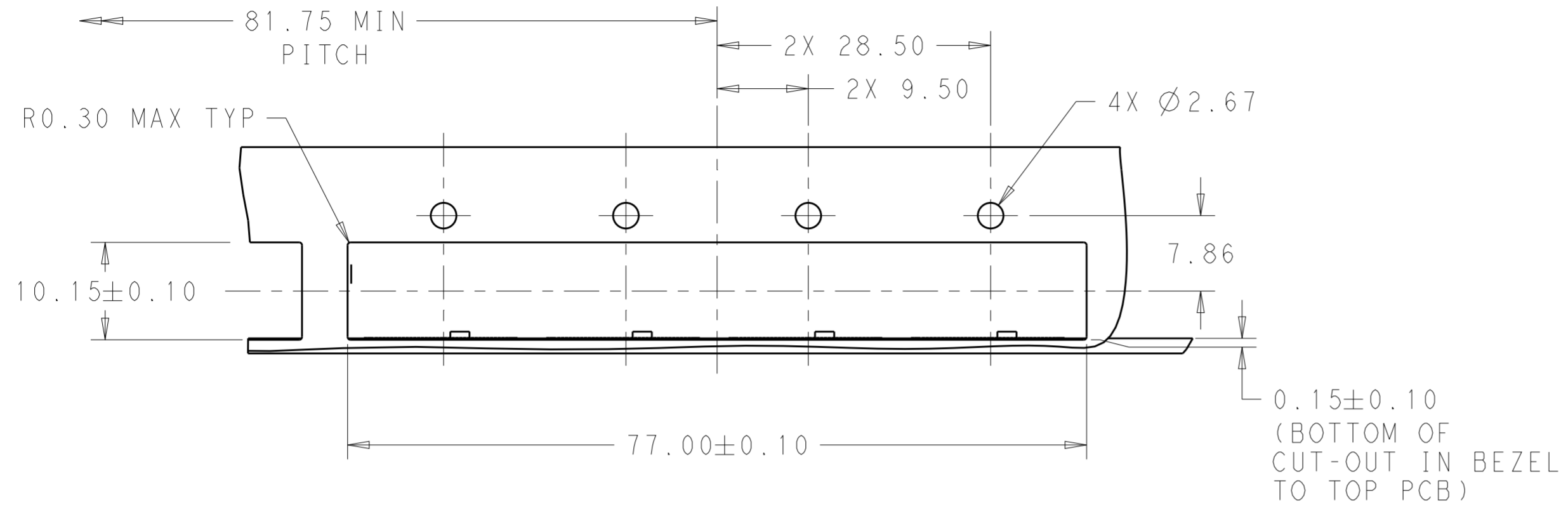

SINGLE SIDE MOUNTING  
SCALE 2:1

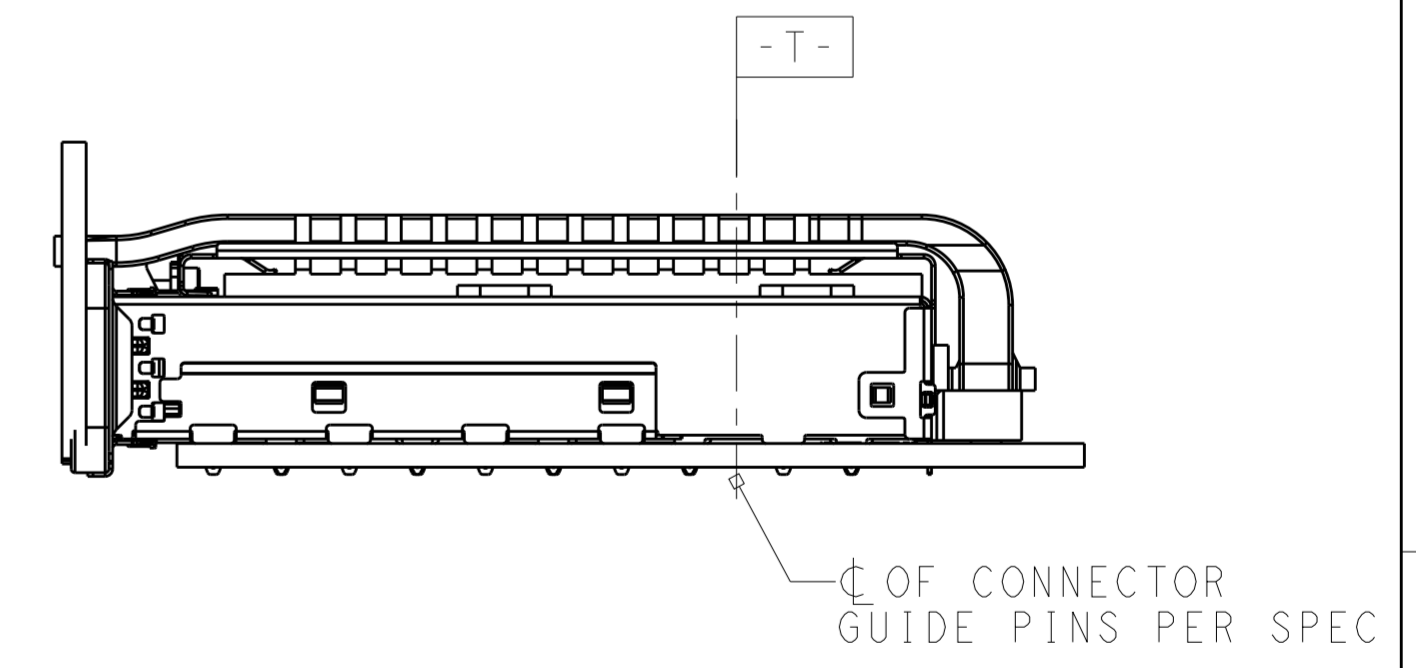
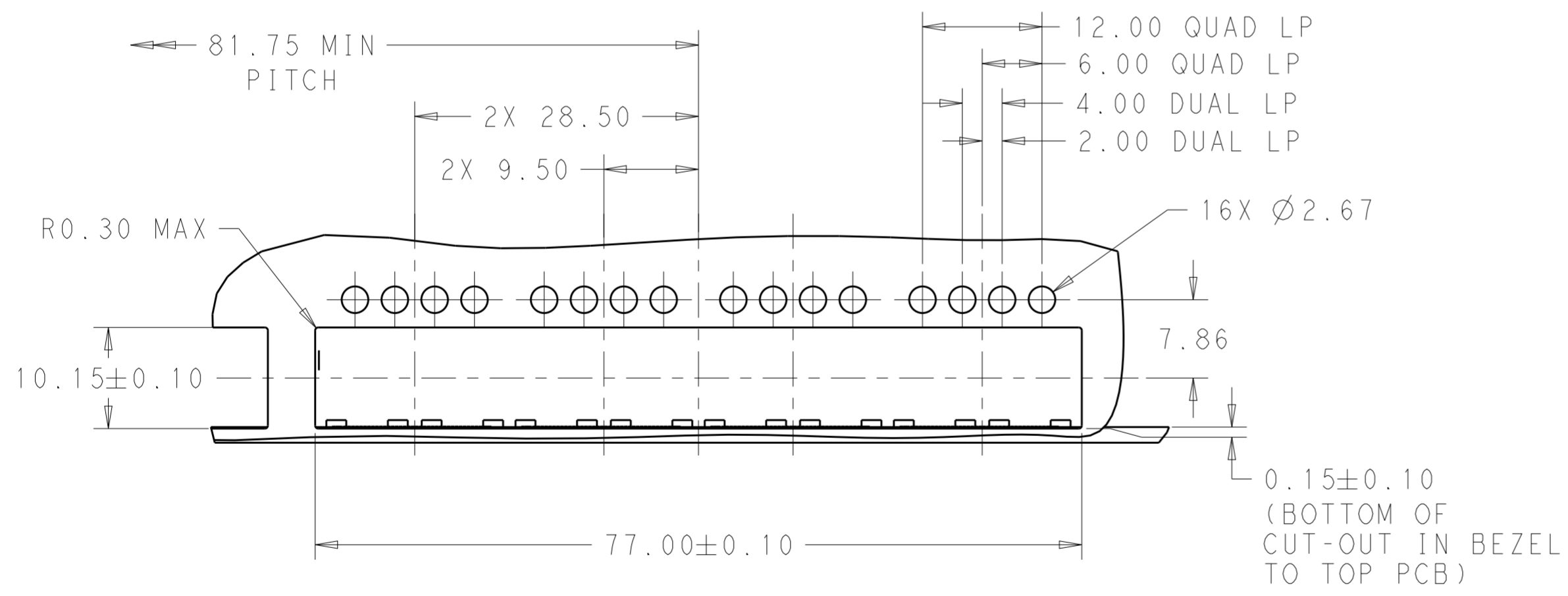

SINGLE SIDE MOUNTING  
SCALE 2:1

|  |           |                                  |   |                    |
|--|-----------|----------------------------------|---|--------------------|
| THIS DRAWING IS A CONTROLLED DOCUMENT.   |           | DWN<br>JASON YANG<br>20 JUN 2014 |  TE Connectivity |                    |
| DIMENSIONS:<br>mm  |           | CHK<br>SEAN HAN<br>01 NOV 2016   |   |                    |
| TOLERANCES UNLESS OTHERWISE SPECIFIED:   |           | APVD<br>-                        | NAME<br>RECEPTACLE CAGE ASSEMBLY WITH HEAT SINKS AND LIGHT PIPES, THRU BEZEL, 1X4, QSFP28, GASKET     |                    |
| 0 PLC ±<br>1 PLC ±0.25<br>2 PLC ±0.2<br>3 PLC ±<br>4 PLC ±<br>ANGLES ±<br>FINISH ± |           | PRODUCT SPEC<br>108-19428        | SIZE<br>114-32023   | RESTRICTED TO<br>- |
| MATERIAL<br>SEE NOTES  | SEE NOTES | WEIGHT<br>-                      | SCALE<br>3:1  | SHEET<br>4 OF 9    |
| CUSTOMER DRAWING   |           | DRAWING NO<br>A200779C-2170785   |   | REV<br>A           |

THIS DRAWING IS UNPUBLISHED. RELEASED FOR PUBLICATION 20  
 © COPYRIGHT 20 BY - ALL RIGHTS RESERVED.

| REVISIONS |     |             |      |     |      |
|-----------|-----|-------------|------|-----|------|
| P         | LTR | DESCRIPTION | DATE | DWN | APVD |
| -         | -   | SEE SHEET 1 | -    | -   | -    |

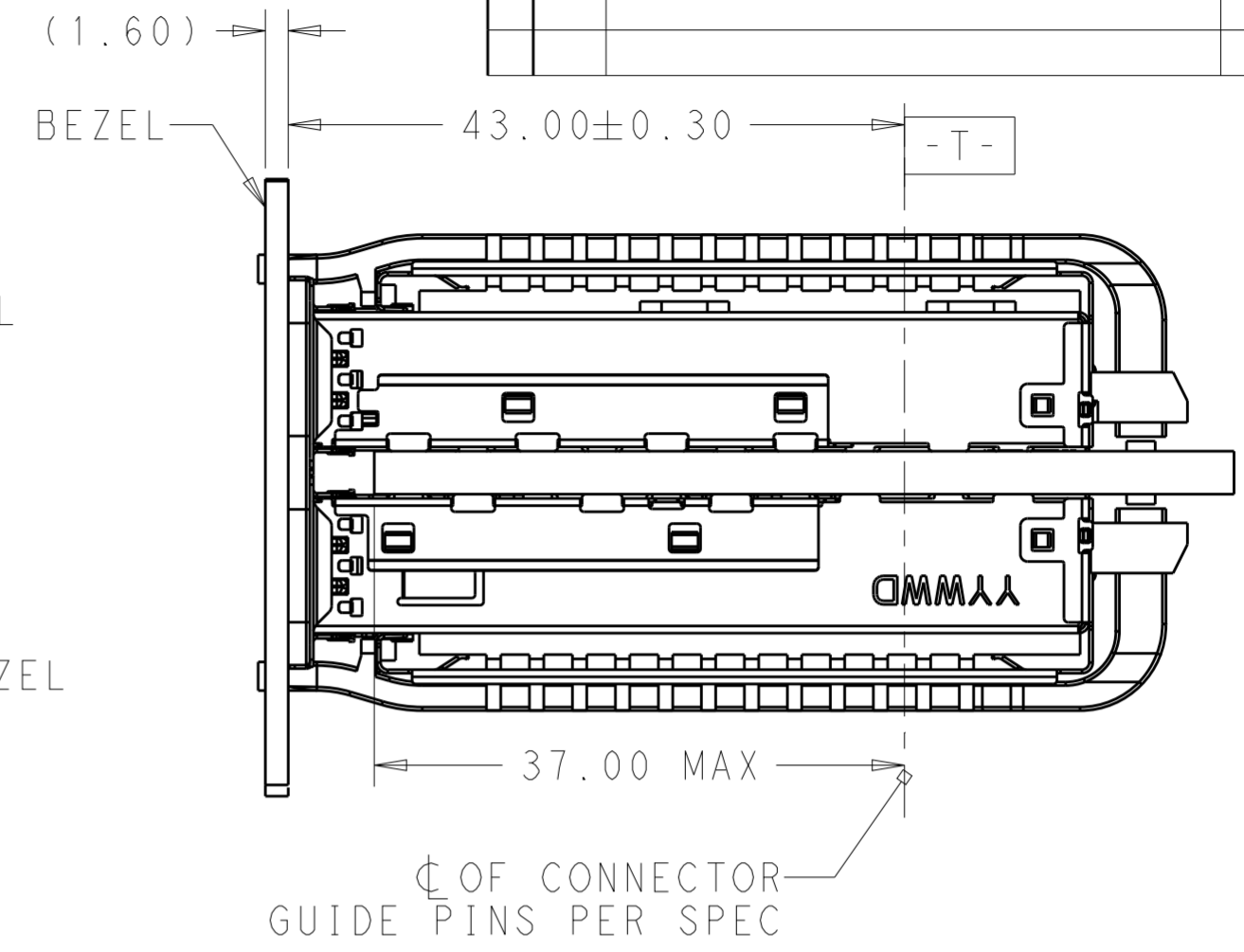
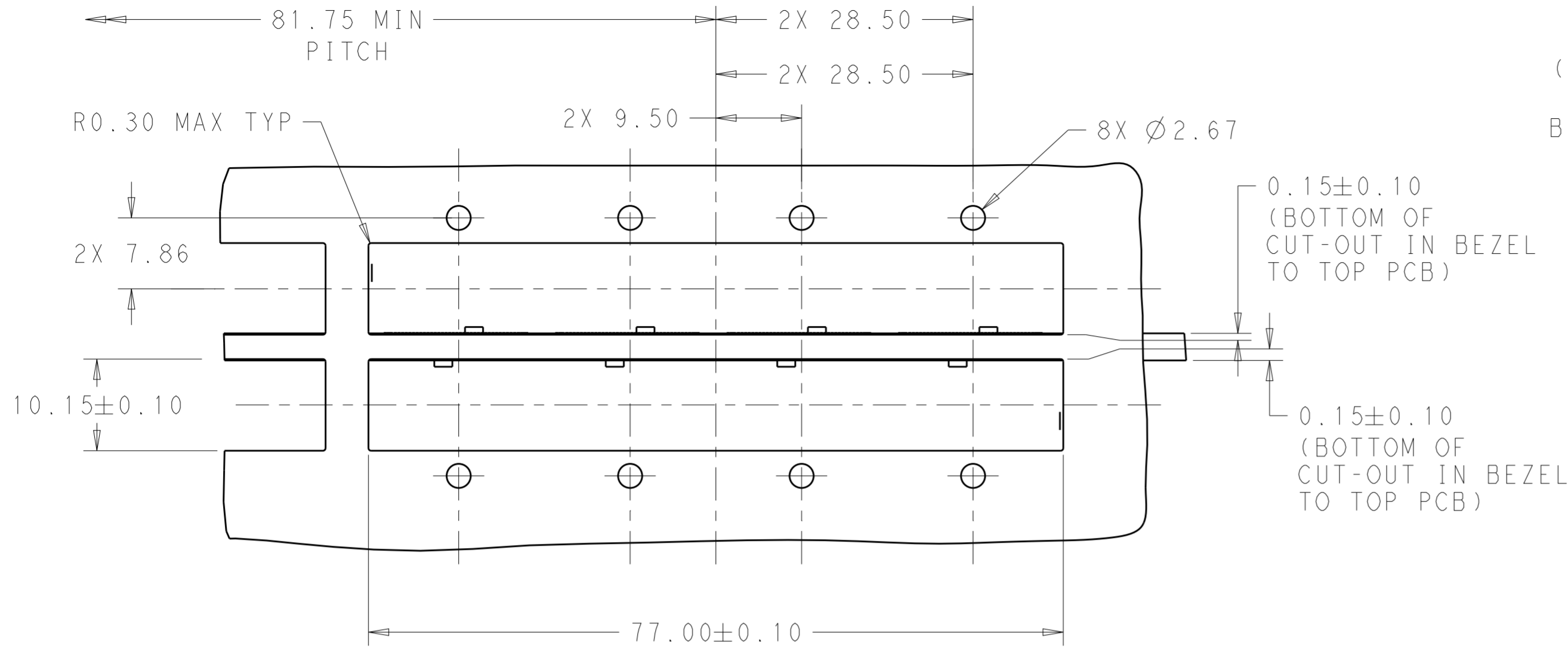

BELLY TO BELLY MOUNTING  
SCALE 2:1

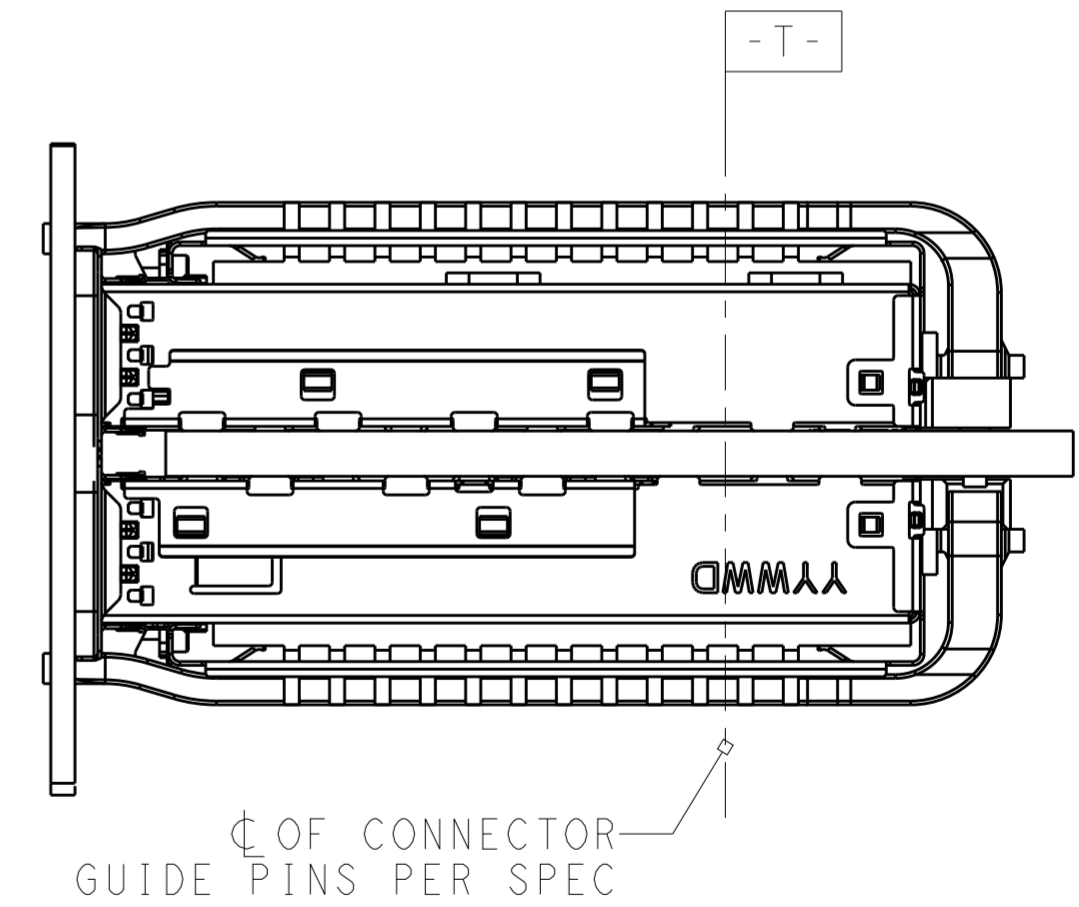
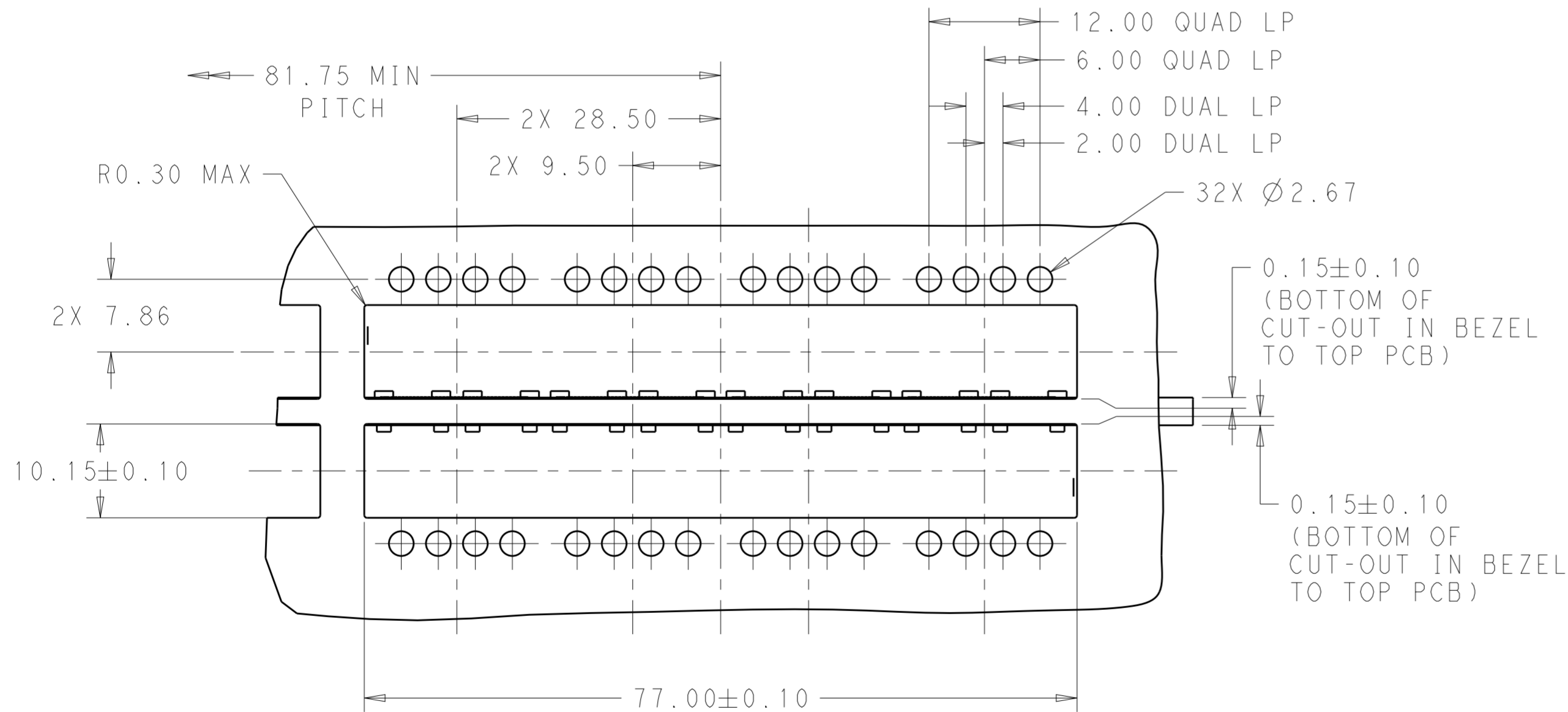

BELLY TO BELLY MOUNTING  
SCALE 2:1

|  |  |                                  |                  |   |               |
|--|--|----------------------------------|------------------|---|---------------|
| THIS DRAWING IS A CONTROLLED DOCUMENT. |  | DWN<br>JASON YANG<br>20 JUN 2014 | TE Connectivity  |   |               |
|  |  | CHK<br>SEAN HAN<br>01 NOV 2016   |                  |   |               |
| DIMENSIONS:                            | TOLERANCES UNLESS OTHERWISE SPECIFIED:   | APVD                             | NAME             | RECEPTACLE CAGE ASSEMBLY WITH HEAT SINKS AND LIGHT PIPES, THRU BEZEL, 1X4, QSFP28, GASKET |               |
| mm                                     | 0 PLC ±<br>1 PLC ±0.25<br>2 PLC ±0.2<br>3 PLC ±<br>4 PLC ±<br>ANGLES ±<br>FINISH | PRODUCT SPEC                     | SIZE             | CAGE CODE   | DRAWING NO    |
| MATERIAL                               | SEE NOTES  | APPLICATION SPEC                 | A2               | 00779   | C-2170785     |
|  |  | WEIGHT                           | CUSTOMER DRAWING |   | RESTRICTED TO |
|  |  |                                  | SCALE            | SHEET   | REV           |
|  |  |                                  | 3:1              | 5 OF 9  | A             |

THIS DRAWING IS UNPUBLISHED. RELEASED FOR PUBLICATION 20  
 © COPYRIGHT 20 BY - ALL RIGHTS RESERVED.

| REVISIONS |     |             |      |      |
|-----------|-----|-------------|------|------|
| P         | LTR | DESCRIPTION | DATE | APVD |
| -         | -   | SEE SHEET 1 | -    | -    |
|           |     |             |      |      |
|           |     |             |      |      |

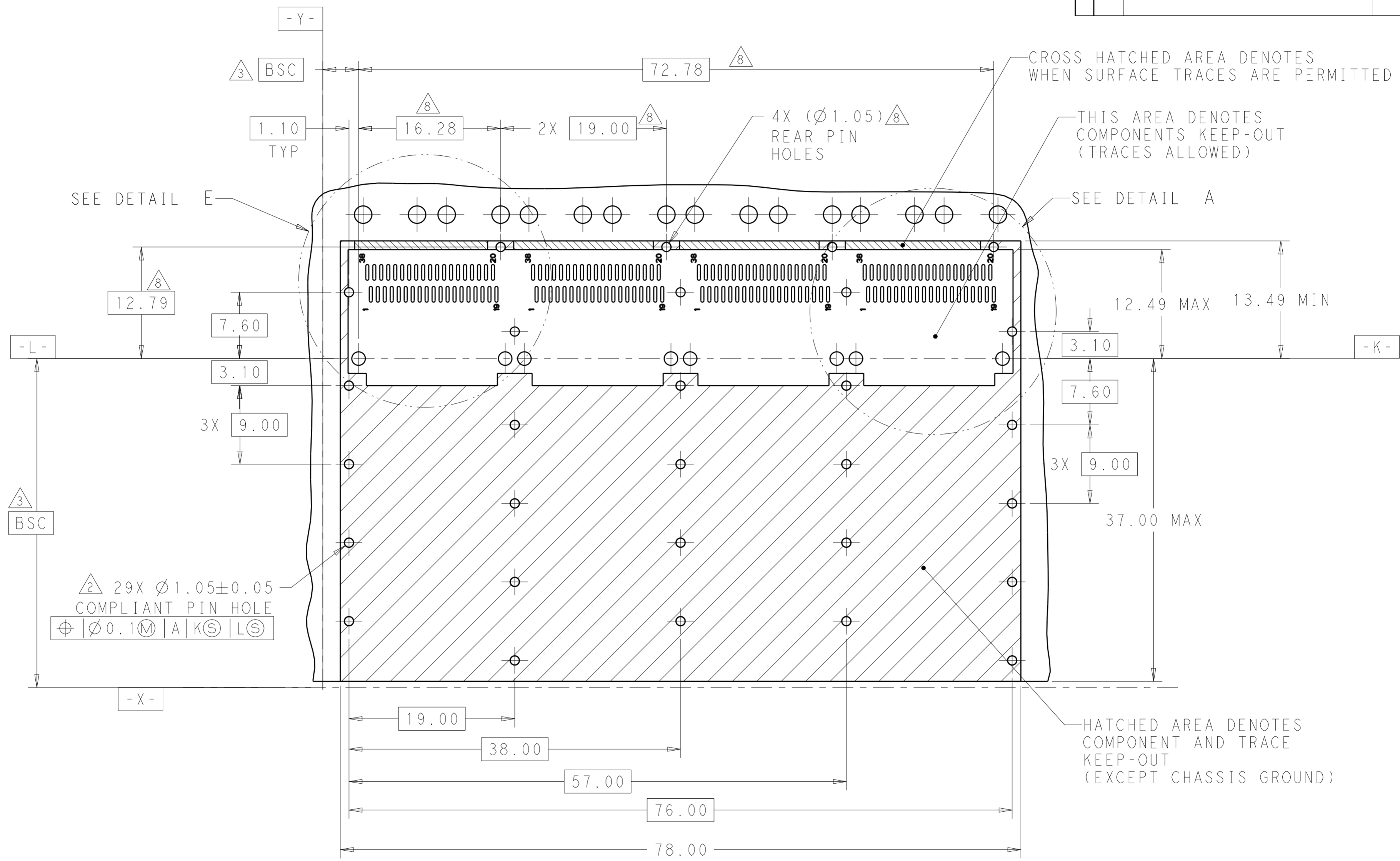

RECOMMENDED PCB LAYOUT  
 SINGLE TYPE  
 PCB TOLERANCE: ±0.05  
 SCALE 3:1

|  |  |                               |  |  |
|--|--|-------------------------------|--|--|
| THIS DRAWING IS A CONTROLLED DOCUMENT. |  | DWN 20 JUN 2014<br>JASON YANG | TE Connectivity  |  |
|  |  | CHK 01 NOV 2016<br>SEAN HAN   |  |  |
| DIMENSIONS: mm                         |  | APVD -                        | NAME RECEPTACLE CAGE ASSEMBLY WITH HEAT SINKS AND LIGHT PIPES, THRU BEZEL, 1X4, QSFP28, GASKET |  |
| TOLERANCES UNLESS OTHERWISE SPECIFIED: |  | PRODUCT SPEC 108-19428        | SIZE CAGE CODE DRAWING NO RESTRICTED TO  |  |
| 0 PLC ±-                               |  | APPLICATION SPEC 114-32023    | A200779 C-2170785  |  |
| 1 PLC ±0.25                            |  | WEIGHT -                      | SCALE 3:1 SHEET 6 OF 9 REV A   |  |
| 2 PLC ±0.2                             |  | CUSTOMER DRAWING              |  |  |
| 3 PLC ±-                               |  |                               |  |  |
| 4 PLC ±-                               |  |                               |  |  |
| ANGLES ±-                              |  |                               |  |  |
| FINISH SEE NOTES                       |  |                               |  |  |

THIS DRAWING IS UNPUBLISHED. RELEASED FOR PUBLICATION 20  
 © COPYRIGHT 20 BY - ALL RIGHTS RESERVED.

| REVISIONS |     |             |      |      |
|-----------|-----|-------------|------|------|
| P         | LTR | DESCRIPTION | DATE | APVD |
| -         | -   | SEE SHEET 1 | -    | -    |
|           |     |             |      |      |
|           |     |             |      |      |

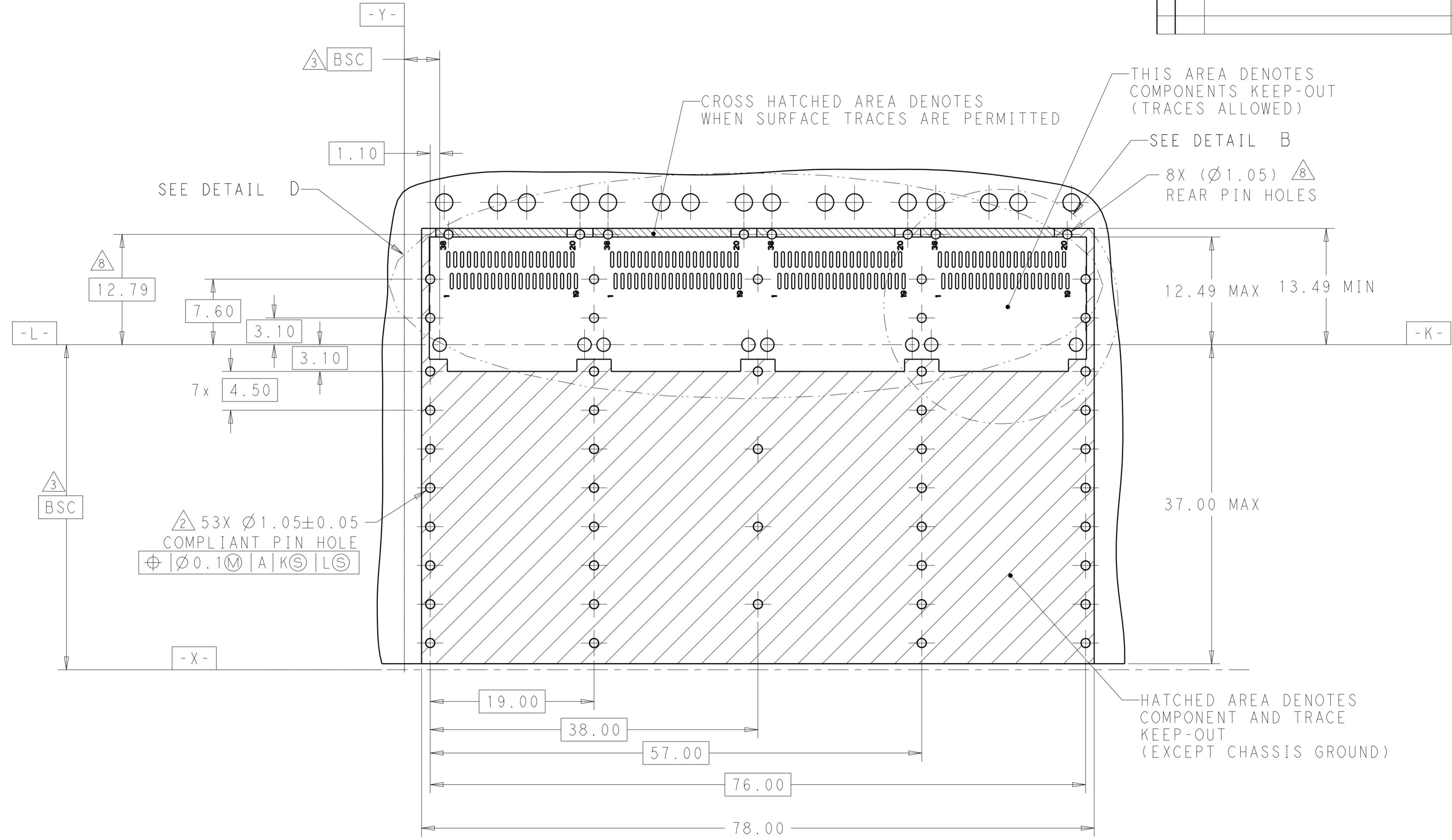

RECOMMENDED PCB LAYOUT  
 BELLY TO BELLY TYPE  
 PCB TOLERANCE: ±0.05  
 SCALE 3:1

|  |  |                                  |   |   |
|--|--|----------------------------------|---|---|
| THIS DRAWING IS A CONTROLLED DOCUMENT.   |  | DWN<br>JASON YANG<br>20 JUN 2014 |  TE Connectivity |   |
|  |  | CHK<br>SEAN HAN<br>01 NOV 2016   |   |   |
| DIMENSIONS:<br>mm  |  | APVD<br>-                        |   | NAME<br>RECEPTACLE CAGE ASSEMBLY<br>WITH HEAT SINKS AND LIGHT PIPES,<br>THRU BEZEL, 1X4, QSFP28, GASKET |
| TOLERANCES UNLESS OTHERWISE SPECIFIED:<br>0 PLC ±<br>1 PLC ±0.25<br>2 PLC ±0.2<br>3 PLC ±<br>4 PLC ±<br>ANGLES ±<br>FINISH |  | PRODUCT SPEC<br>108-19428        |   | SIZE<br>A200779   |
| MATERIAL<br>SEE NOTES  |  | APPLICATION SPEC<br>114-32023    |   | DRAWING NO<br>C-2170785   |
|  |  | WEIGHT<br>-                      |   | RESTRICTED TO<br>-  |
|  |  | CUSTOMER DRAWING                 |   | SCALE 3:1 SHEET 7 OF 9 REV A  |



THIS DRAWING IS UNPUBLISHED. RELEASED FOR PUBLICATION 20  
 © COPYRIGHT 20 BY - ALL RIGHTS RESERVED.

| REVISIONS |     |             |      |      |
|-----------|-----|-------------|------|------|
| P         | LTR | DESCRIPTION | DATE | APVD |
| -         | -   | SEE SHEET 1 | -    | -    |
|           |     |             |      |      |
|           |     |             |      |      |

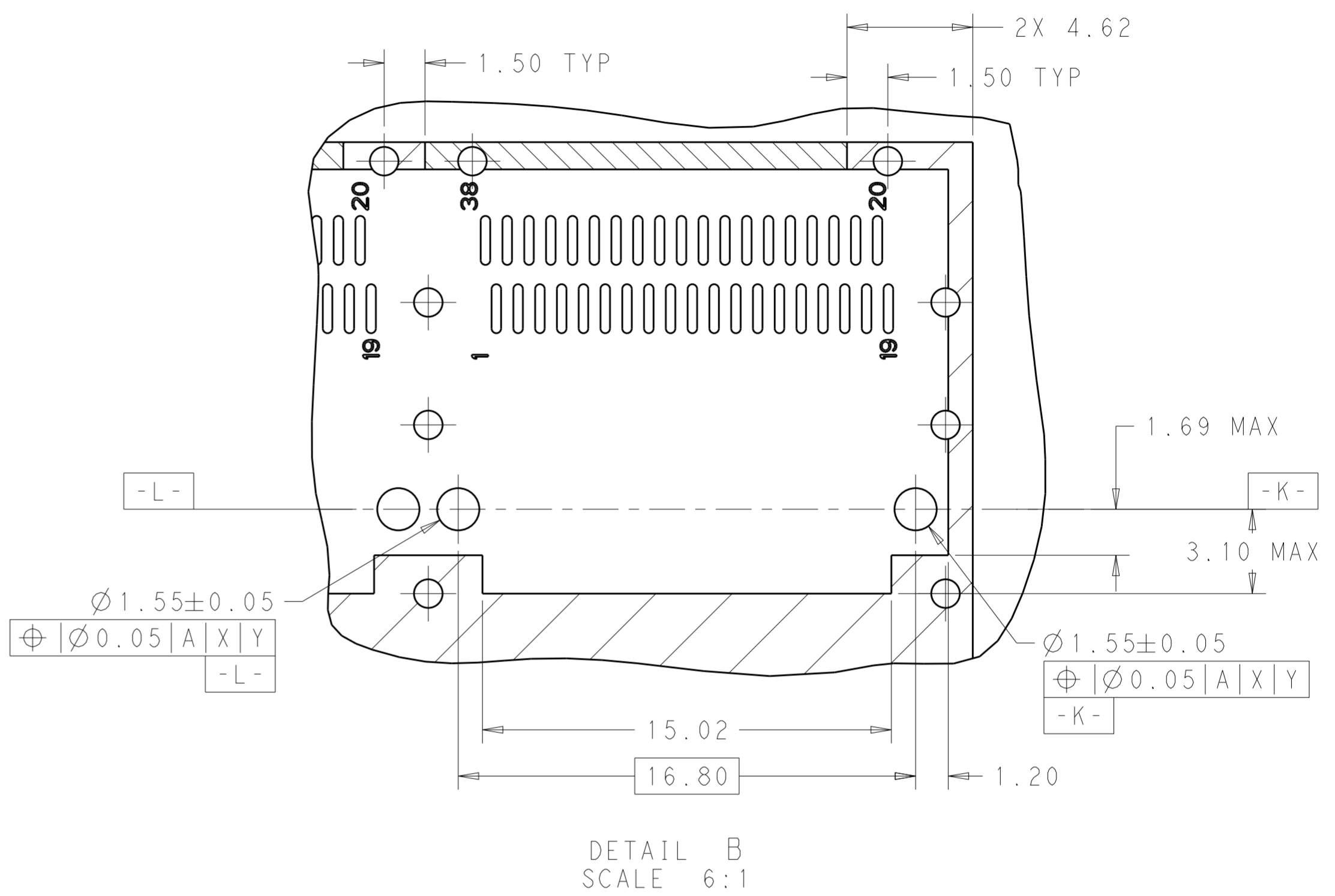
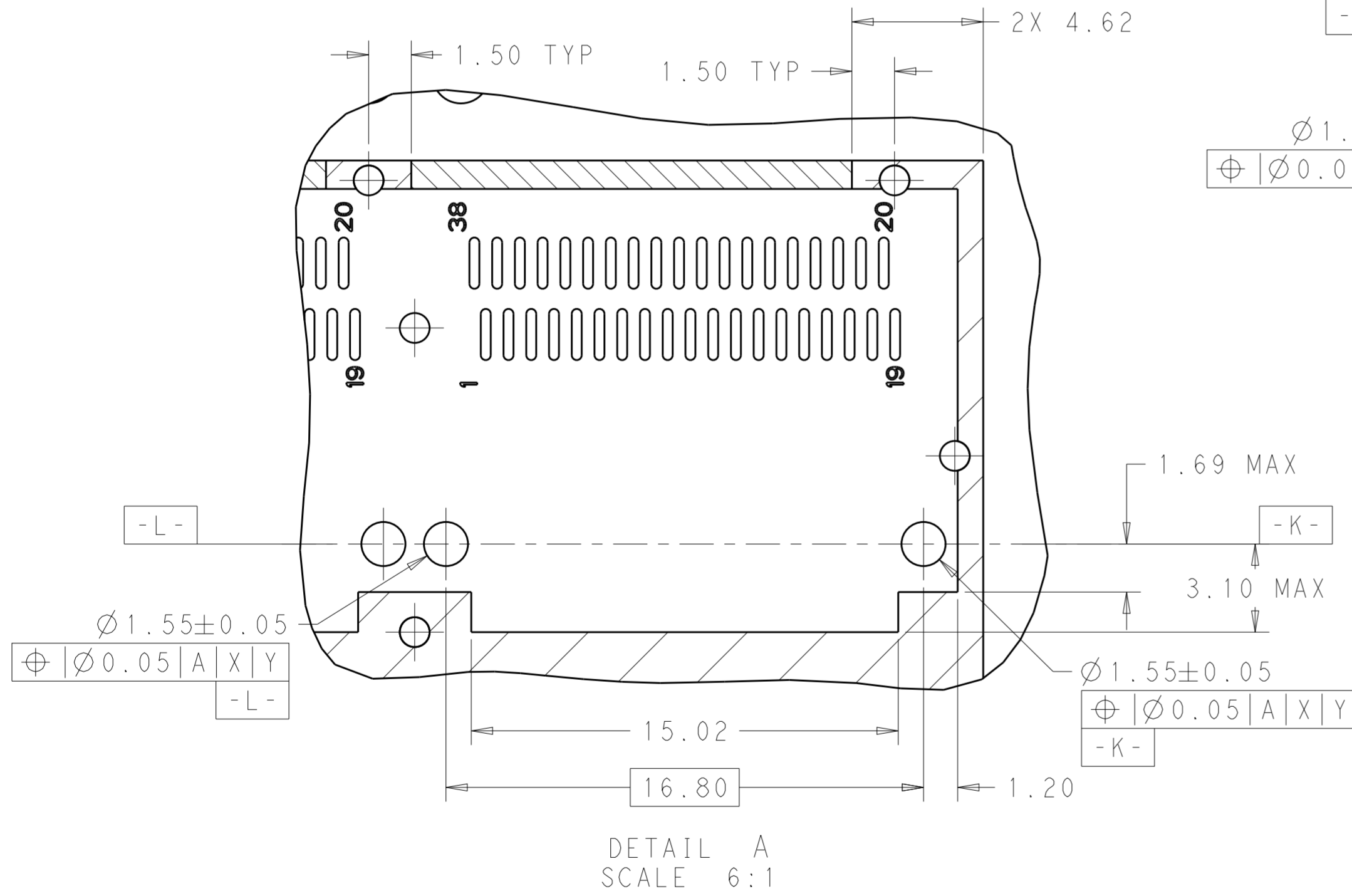

|  |  |                               |   |
|--|--|-------------------------------|---|
| THIS DRAWING IS A CONTROLLED DOCUMENT. |  | DWN 20 JUN 2014<br>JASON YANG | TE Connectivity   |
|  |  | CHK 01 NOV 2016<br>SEAN HAN   |   |
| DIMENSIONS:                            | TOLERANCES UNLESS OTHERWISE SPECIFIED:                     | APVD -                        | NAME  |
| mm                                     | 0 PLC ±<br>1 PLC ±0.25<br>2 PLC ±0.2<br>3 PLC ±<br>4 PLC ± | PRODUCT SPEC                  | RECEPTACLE CAGE ASSEMBLY WITH HEAT SINKS AND LIGHT PIPES, THRU BEZEL, 1X4, QSFP28, GASKET |
|  | ANGLES ±   | APPLICATION SPEC              | SIZE CAGE CODE DRAWING NO   |
| MATERIAL                               | FINISH   | WEIGHT                        | A200779 C-2170785   |
| SEE NOTES                              | SEE NOTES  | CUSTOMER DRAWING              | RESTRICTED TO   |
|  |  | SCALE 3:1                     | SHEET 8 OF 9 REV A  |

THIS DRAWING IS UNPUBLISHED. RELEASED FOR PUBLICATION 20  
 © COPYRIGHT 20 BY - ALL RIGHTS RESERVED.

| REVISIONS |     |             |      |      |
|-----------|-----|-------------|------|------|
| P         | LTR | DESCRIPTION | DATE | APVD |
| -         |     | SEE SHEET 1 | -    | -    |
|           |     |             |      |      |
|           |     |             |      |      |

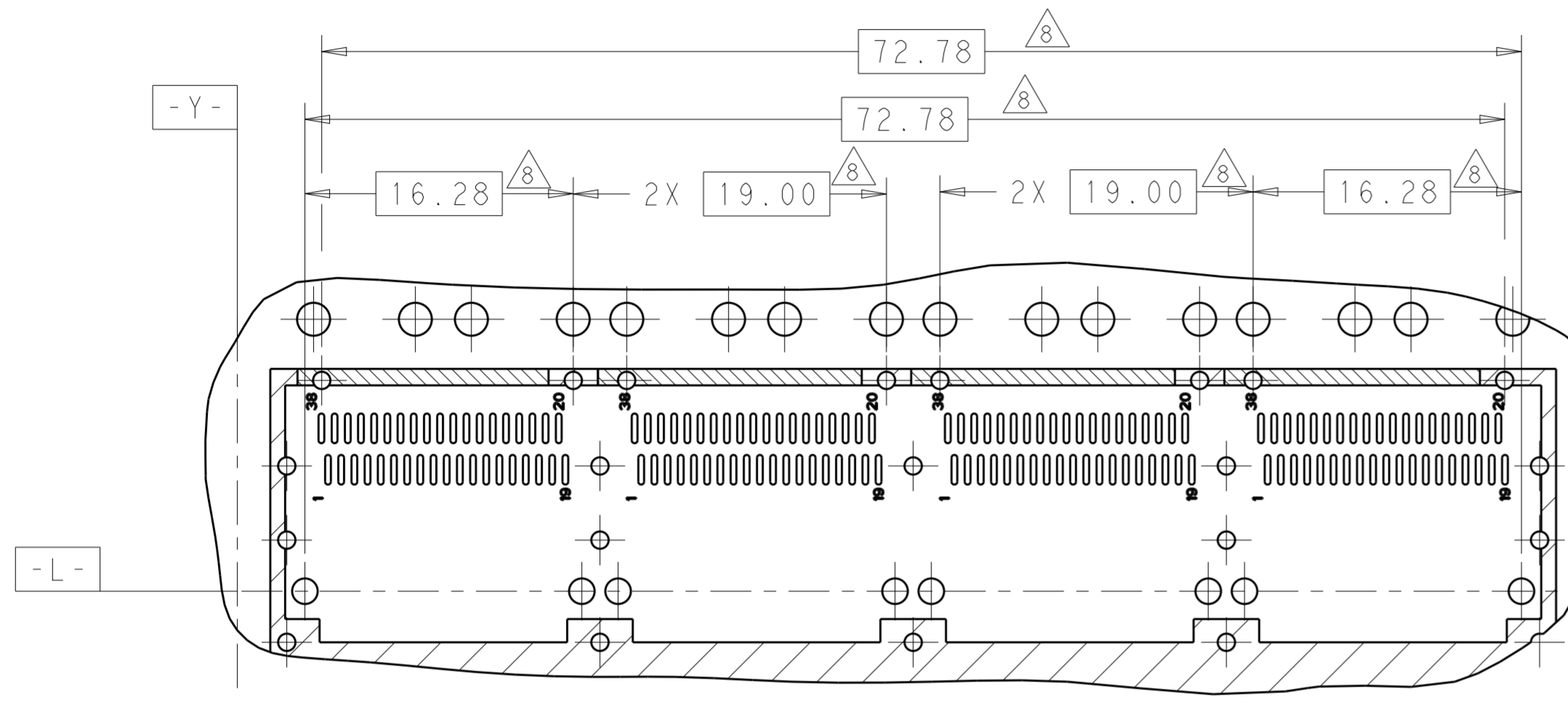

DETAIL D  
SCALE 3:1

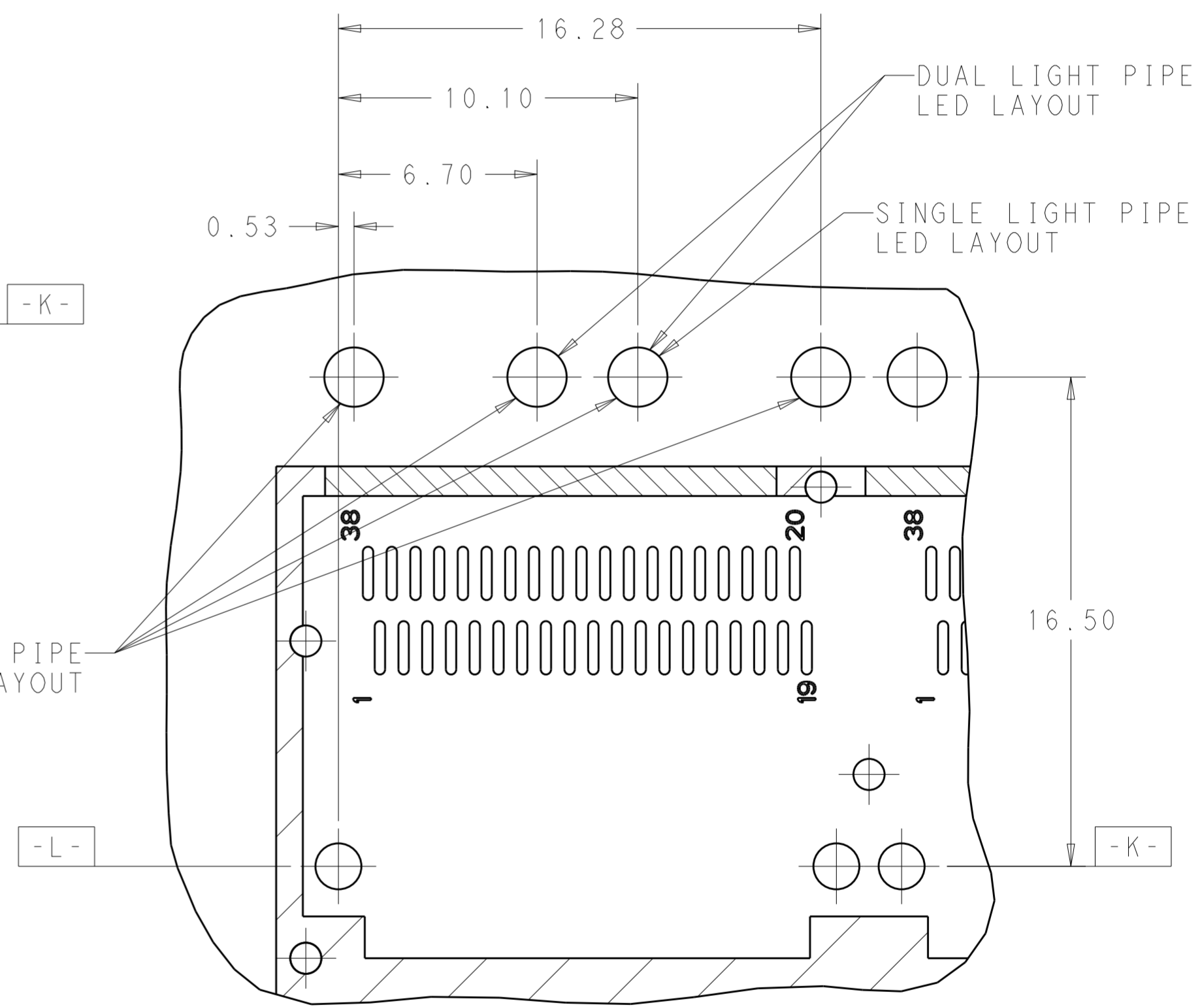

QUAD LIGHT PIPE  
LED LAYOUT

DETAIL E  
SCALE 6:1

|  |  |  |                            |   |
|--|--|--|----------------------------|---|
| THIS DRAWING IS A CONTROLLED DOCUMENT.                     |  | DWN 20 JUN 2014<br>JASON YANG          | <b>STE</b> TE Connectivity |   |
|  |  | CHK 01 NOV 2016<br>SEAN HAN            |                            |   |
| DIMENSIONS:<br>mm  |  | TOLERANCES UNLESS OTHERWISE SPECIFIED: |                            | NAME<br>RECEPTACLE CAGE ASSEMBLY WITH HEAT SINKS AND LIGHT PIPES, THRU BEZEL, 1X4, QSFP28, GASKET |
| 0 PLC ±<br>1 PLC ±0.25<br>2 PLC ±0.2<br>3 PLC ±<br>4 PLC ± |  | APVD -                                 |                            | PRODUCT SPEC<br>108-19428   |
| MATERIAL<br>SEE NOTES                                      |  | FINISH<br>SEE NOTES                    |                            | APPLICATION SPEC<br>114-32023   |
|  |  | WEIGHT -                               |                            | SIZE CAGE CODE DRAWING NO<br>A200779 C-2170785  |
|  |  | CUSTOMER DRAWING                       |                            | RESTRICTED TO<br>-  |
|  |  | SCALE 3:1                              |                            | SHEET 9 OF 9 REV A  |