



Chipsmall Limited consists of a professional team with an average of over 10 year of expertise in the distribution of electronic components. Based in Hongkong, we have already established firm and mutual-benefit business relationships with customers from,Europe,America and south Asia,supplying obsolete and hard-to-find components to meet their specific needs.

With the principle of “Quality Parts,Customers Priority,Honest Operation,and Considerate Service”,our business mainly focus on the distribution of electronic components. Line cards we deal with include Microchip,ALPS,ROHM,Xilinx,Pulse,ON,Everlight and Freescale. Main products comprise IC,Modules,Potentiometer,IC Socket,Relay,Connector.Our parts cover such applications as commercial,industrial, and automotives areas.

We are looking forward to setting up business relationship with you and hope to provide you with the best service and solution. Let us make a better world for our industry!



Contact us

Tel: +86-755-8981 8866 Fax: +86-755-8427 6832

Email & Skype: info@chipsmall.com Web: www.chipsmall.com

Address: A1208, Overseas Decoration Building, #122 Zhenhua RD., Futian, Shenzhen, China



THIS DRAWING IS UNPUBLISHED. RELEASED FOR PUBLICATION 20
 © COPYRIGHT 20 BY - ALL RIGHTS RESERVED.

LOC	DIST	REVISIONS					
GP	00	P	LTR	DESCRIPTION	DATE	DWN	APVD
		A		RELEASE	01NOV2016	JY	SH
		B		REVISED PER ECO-16-017012	18NOV2016	JY	SH

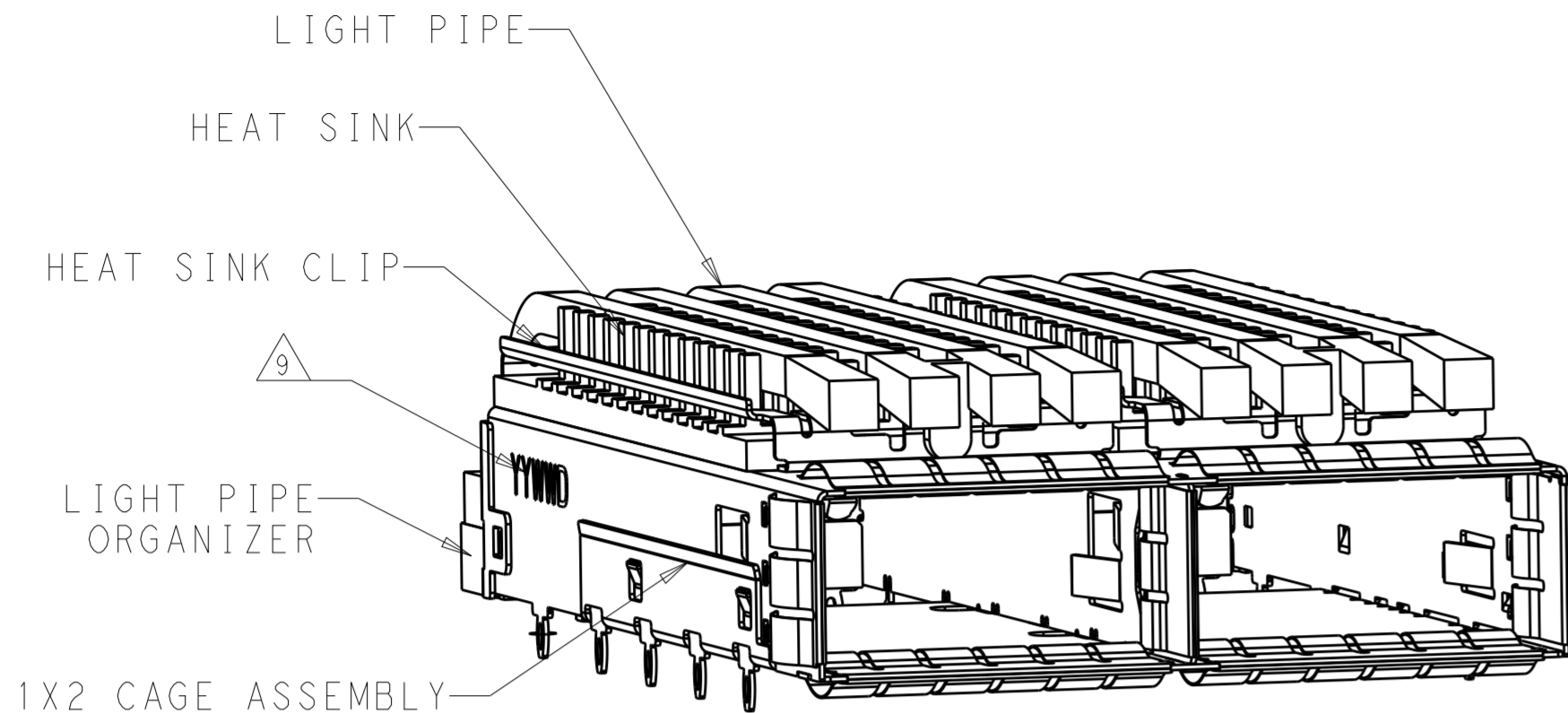

2170826-1 AS SHOWN
SCALE 3:1

- COMPONENTS
 CAGE ASSEMBLY: NICKEL-SILVER ALLOY
 HEAT SINK: ALUMINUM/BLACK ANODIZE
 HEAT SINK CLIP: STAINLESS STEEL
 EMI SPRING: COPPER ALLOY/NICKEL PLATE
 LIGHT PIPE: CLEAR POLYCARBONATE
- REFERENCE APPLICATION SPECIFICATION 114-32023 FOR RECOMMENDED DRILL HOLE DIAMETER AND PLATING THICKNESS
- DATUM AND BASIC DIMENSION ESTABLISHED BY CUSTOMER
- DIMENSION APPLIES WITH MODULE INSERTED IN CAGE
- HEAT SINKS, HEAT SINK CLIPS AND LIGHT PIPES ARE SHIPPED ASSEMBLED ON CAGE
- MINIMUM PC BOARD THICKNESS: SINGLE SIDED: 1.57 MIN
DOUBLE SIDED: 2.20 MIN
- DATUM **-A-** IS TOP SURFACE OF THE HOST BOARD.
- MATES WITH QSFP28 MSA COMPATIBLE TRANSCEIVER.
- DATE CODE (YYWWD) MARKED APPROXIMATELY AS SHOWN.

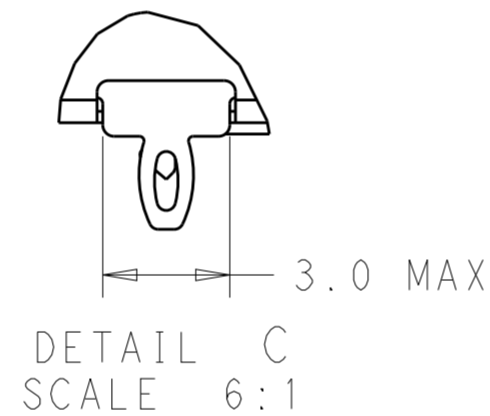
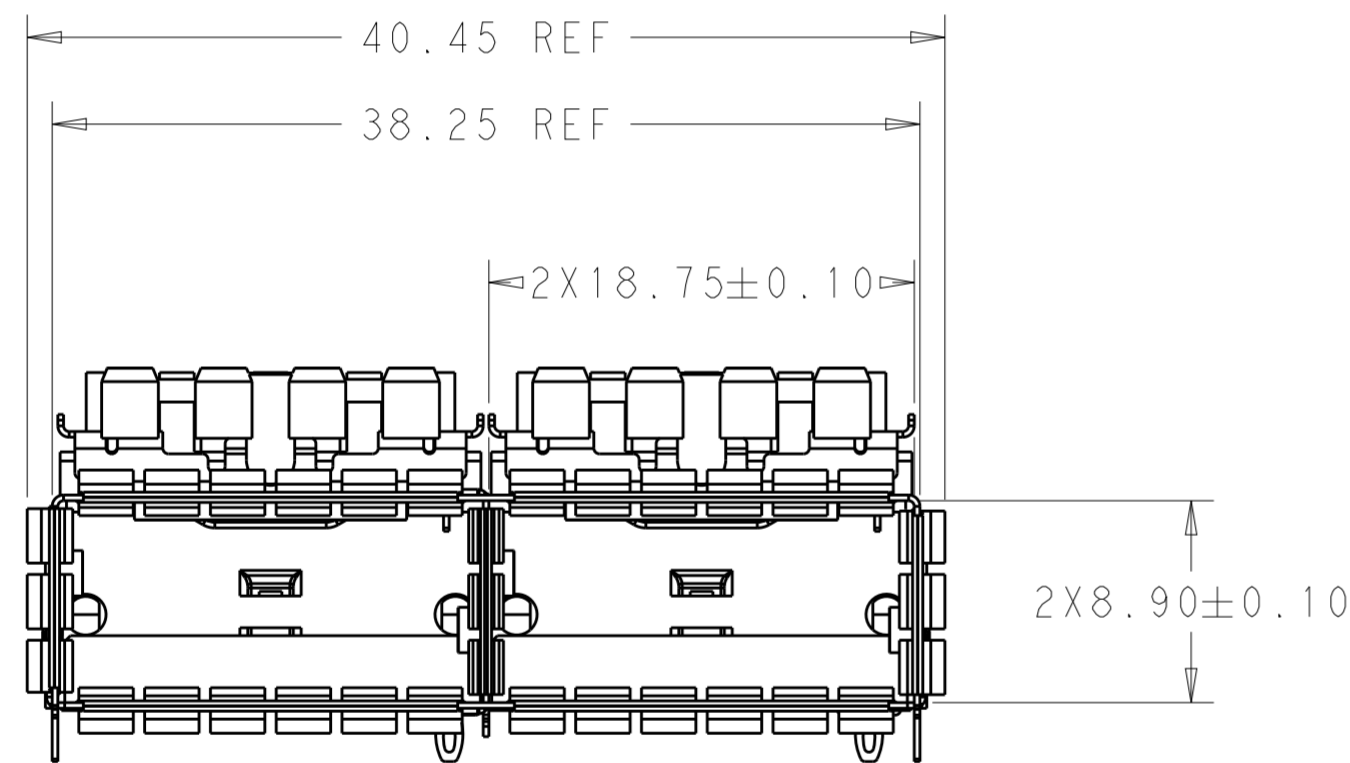

3.0 MAX

DETAIL C
SCALE 6:1

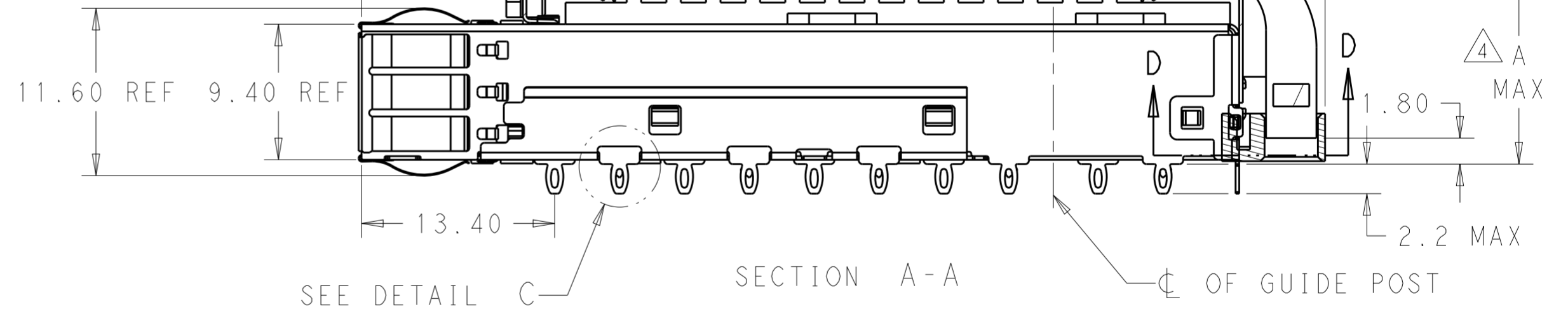

SECTION A-A
SEE DETAIL C OF GUIDE POST

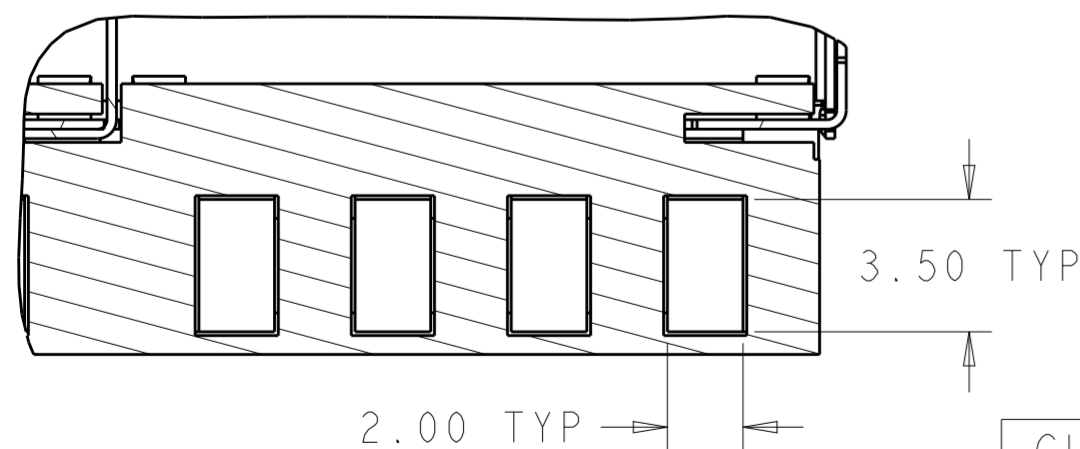

SURFACE OF LIGHT INPUT
SECTION D-D
SCALE 5:1

CUSTOMERIZED HEAT SINK	Y	19.5	2170826-6
CUSTOMERIZED HEAT SINK	Y	14.9	2170826-5
CUSTOMERIZED HEAT SINK	N	20.0	2170826-4
CUSTOMERIZED HEAT SINK	Y	20.0	2170826-3
SAN HEAT SINK	N	16.0	2170826-2
SAN HEAT SINK	Y	16.0	2170826-1
HEAT SINK APPLICATION	ORGANIZER	DIM A	P/N

THIS DRAWING IS A CONTROLLED DOCUMENT.		DWN BING LIU 16SEP2014	TE Connectivity
		CHK JASON YANG 16SEP2014	
		APVD 01NOV2016	NAME RECEPTACLE CAGE ASSEMBLY WITH HEAT SINKS AND LIGHT PIPES, THRU BEZEL, 1X2, QSFP28, SPRING
DIMENSIONS: mm		TOLERANCES UNLESS OTHERWISE SPECIFIED: 0 PLC ± 1 PLC ±0.25 2 PLC ±0.2 3 PLC ± 4 PLC ± ANGLES ± FINISH ±	PRODUCT SPEC 108-19428
MATERIAL		SEE NOTES	APPLICATION SPEC 114-32023
SEE NOTES		SEE NOTES	WEIGHT -
		CUSTOMER DRAWING	SIZE A2
			CAGE CODE 00779
			DRAWING NO C-2170826
			RESTRICTED TO -
			SCALE 3:1
			SHEET 1 OF 10
			REV B

THIS DRAWING IS UNPUBLISHED. RELEASED FOR PUBLICATION 20
 © COPYRIGHT 20 BY - ALL RIGHTS RESERVED.

LOC		DIST		REVISIONS			
P	LTR	DESCRIPTION	DATE	DWN	APVD		
-	-	SEE SHEET 1	-	-	-		

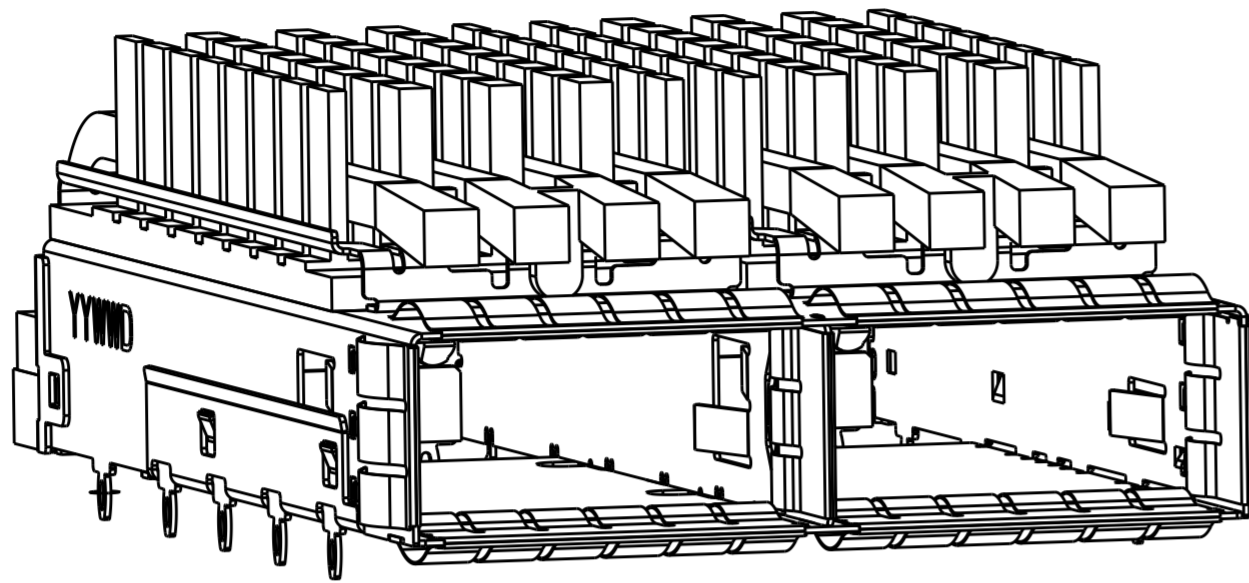

2170826-3 WITH CUSTOMIZED HEAT SINK
 SCALE 3:1

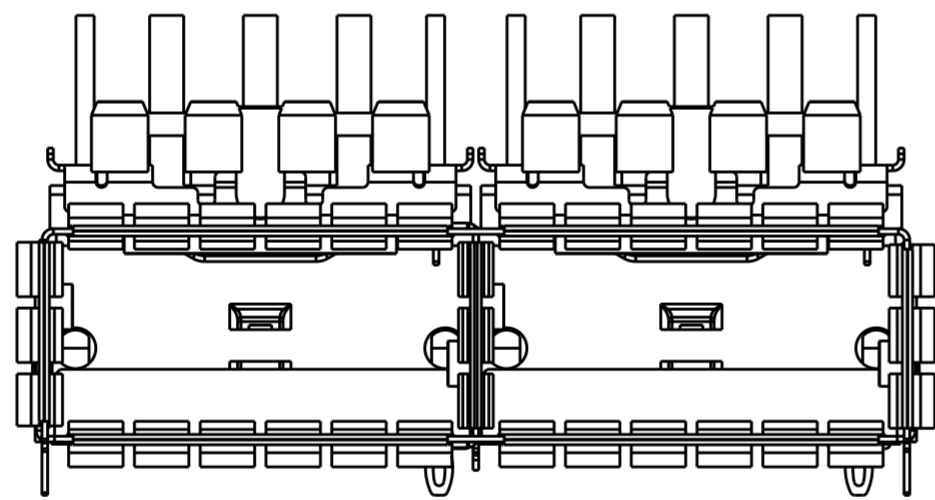

2170826-3 AS SHOWN
 UNSPECIFIED DIMENSIONS ARE SAME AS 2170826-1
 SCALE 3:1

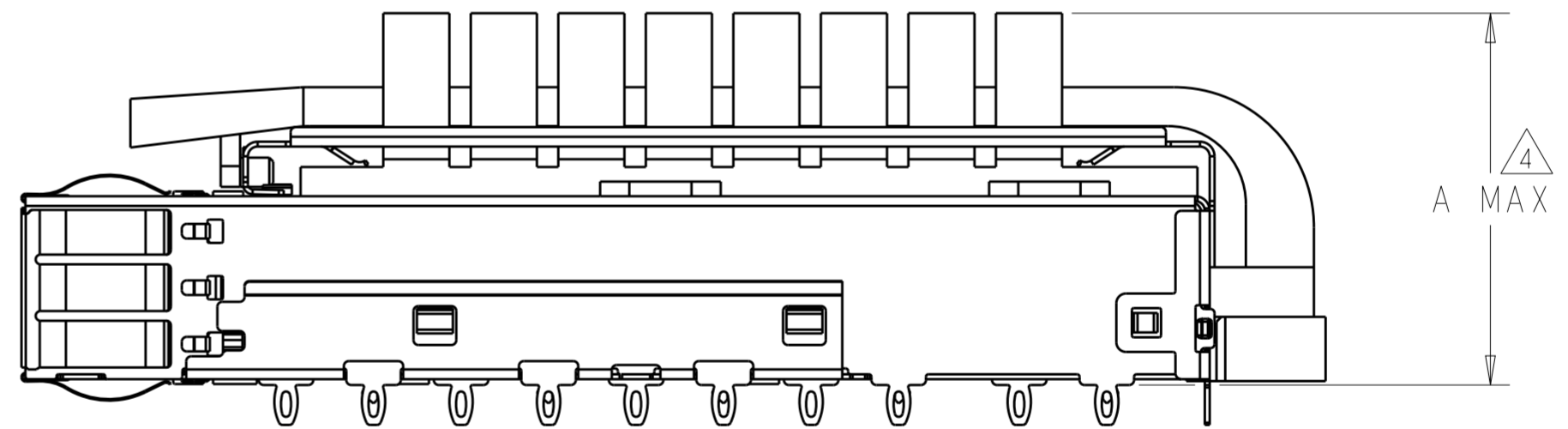

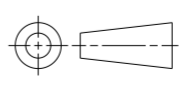
THIS DRAWING IS A CONTROLLED DOCUMENT.		DWN BING LIU 16SEP2014	 TE Connectivity	
DIMENSIONS: mm		CHK JASON YANG 16SEP2014		
TOLERANCES UNLESS OTHERWISE SPECIFIED:		APVD - 01NOV2016	NAME RECEPTACLE CAGE ASSEMBLY WITH HEAT SINKS AND LIGHT PIPES, THRU BEZEL, 1X2, QSFP28, SPRING	
		PRODUCT SPEC 108-19428	SIZE A200779	
MATERIAL SEE NOTES material_2		APPLICATION SPEC 114-32023	DRAWING NO C-2170826	
FINISH SEE NOTES finish_spec_2		WEIGHT -	RESTRICTED TO -	
CUSTOMER DRAWING		SCALE 3:1	SHEET 2 OF 10	
				REV B

THIS DRAWING IS UNPUBLISHED. RELEASED FOR PUBLICATION 20
 © COPYRIGHT 20 BY - ALL RIGHTS RESERVED.

LOC		DIST		REVISIONS			
P	LTR	DESCRIPTION	DATE	DWN	APVD		
-		SEE SHEET 1	-	-	-		

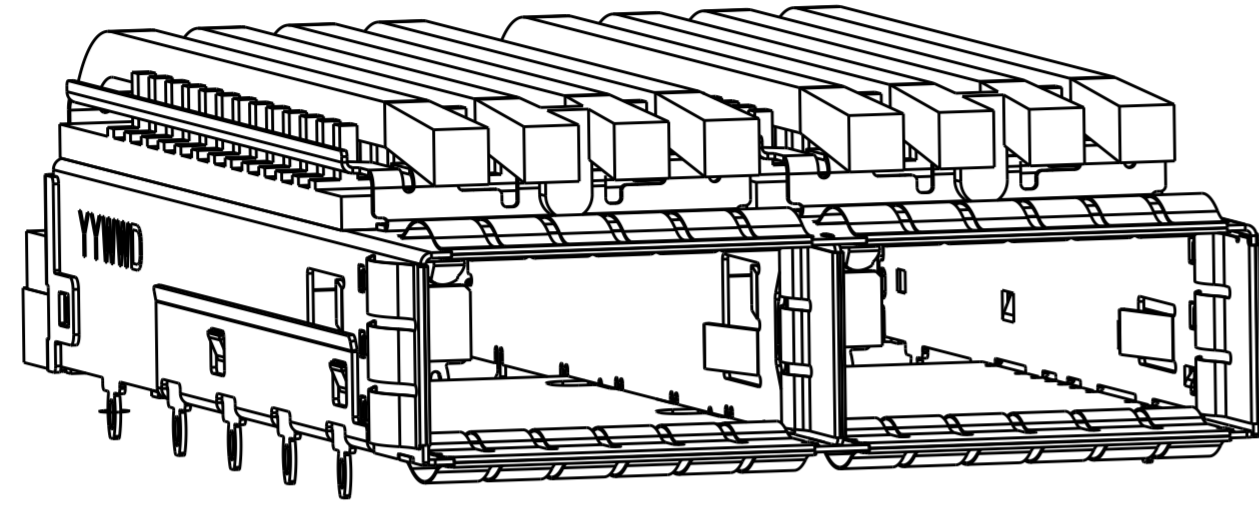

2170826-5 WITH CUSTOMIZED HEAT SINK
 SCALE 3:1

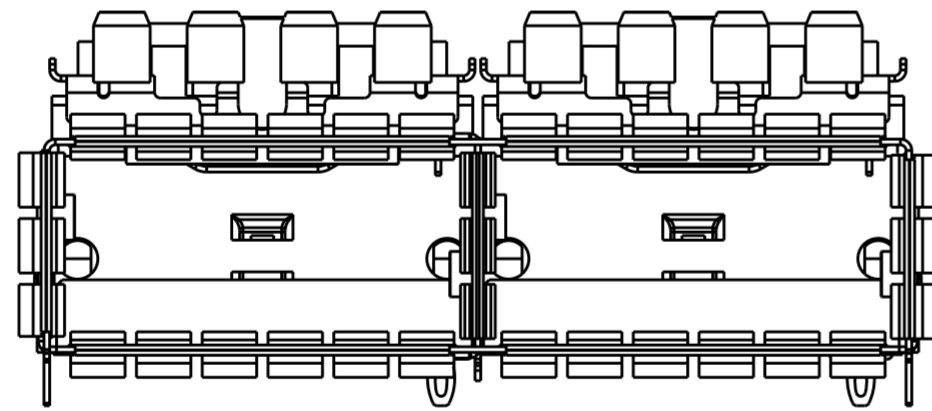

2170826-5 AS SHOWN
 UNSPECIFIED DIMENSIONS ARE SAME AS 2170826-1
 SCALE 3:1

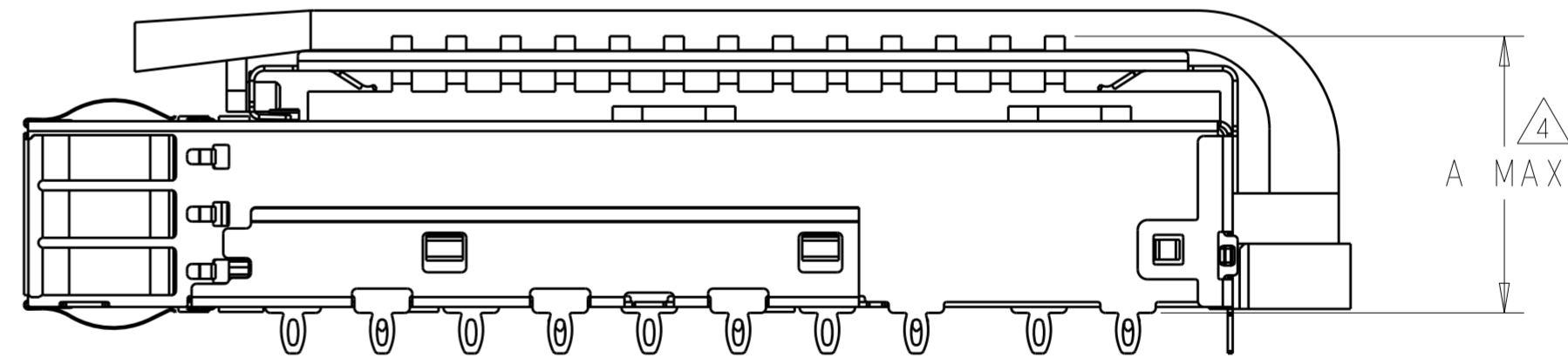

THIS DRAWING IS A CONTROLLED DOCUMENT.		DWN BING LIU 16SEP2014	 TE Connectivity	
DIMENSIONS: mm		CHK JASON YANG 16SEP2014		
TOLERANCES UNLESS OTHERWISE SPECIFIED:		APVD - 01NOV2016	NAME RECEPTACLE CAGE ASSEMBLY WITH HEAT SINKS AND LIGHT PIPES, THRU BEZEL, 1X2, QSFP28, SPRING	
0 PLC ±	1 PLC ±0.25	PRODUCT SPEC 108-19428	SIZE 114-32023	CAGE CODE A200779
2 PLC ±0.2	3 PLC ±	APPLICATION SPEC 114-32023	DRAWING NO C-2170826	RESTRICTED TO -
4 PLC ±	ANGLES ±	WEIGHT -	SCALE 3:1 SHEET 3 OF 10 REV B	
MATERIAL SEE NOTES material_2	FINISH SEE NOTES finish_spec_2	CUSTOMER DRAWING		

THIS DRAWING IS UNPUBLISHED. RELEASED FOR PUBLICATION 20
 © COPYRIGHT 20 BY - ALL RIGHTS RESERVED.

LOC		DIST		REVISIONS			
P	LTR	DESCRIPTION	DATE	DWN	APVD		
-		SEE SHEET 1	-	-	-		

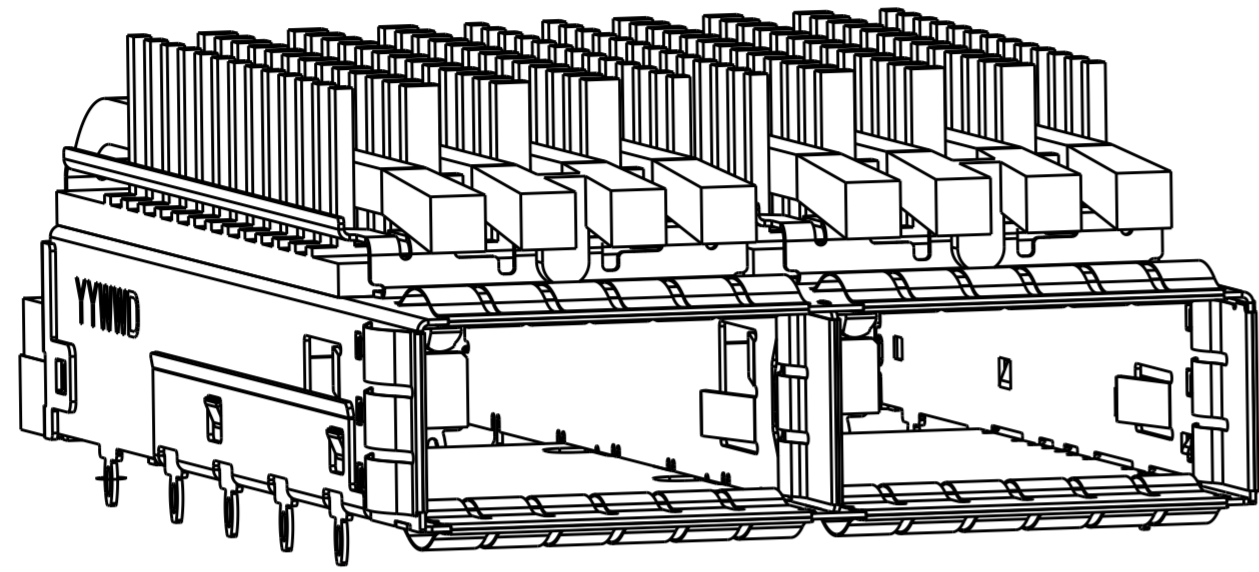

2170826-6 WITH CUSTOMIZED HEAT SINK
 SCALE 3:1

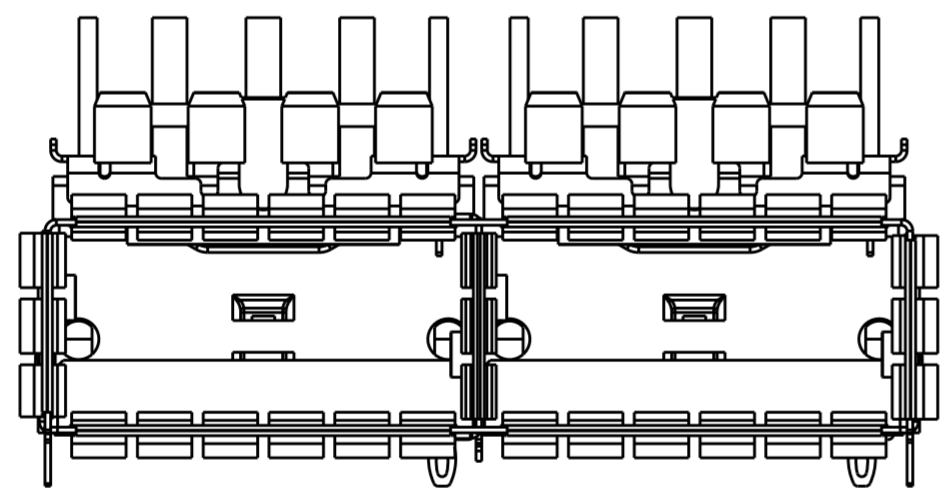

2170826-6 AS SHOWN
 UNSPECIFIED DIMENSIONS ARE SAME AS 2170826-1
 SCALE 3:1

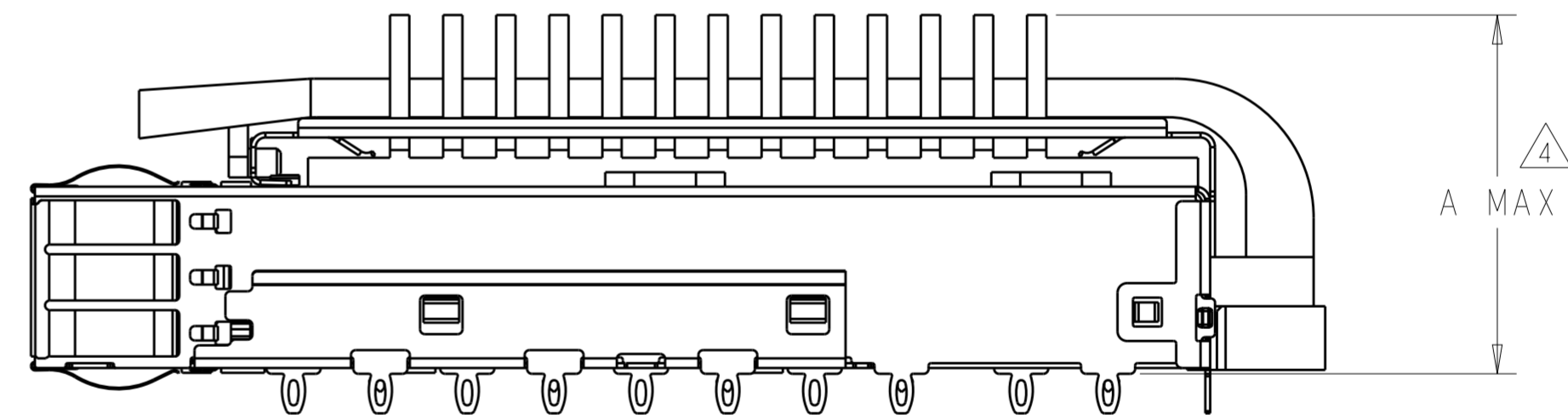

THIS DRAWING IS A CONTROLLED DOCUMENT.		DWN BING LIU 16SEP2014	 TE Connectivity	
DIMENSIONS: mm		CHK JASON YANG 16SEP2014		
TOLERANCES UNLESS OTHERWISE SPECIFIED:		APVD - 01NOV2016	NAME RECEPTACLE CAGE ASSEMBLY WITH HEAT SINKS AND LIGHT PIPES, THRU BEZEL, 1X2, QSFP28, SPRING	
0 PLC ±-	1 PLC ±0.25	PRODUCT SPEC 108-19428	SIZE 114-32023	RESTRICTED TO -
2 PLC ±0.2	3 PLC ±-	APPLICATION SPEC	SCALE 3:1	SHEET 4 OF 10
4 PLC ±-	ANGLES ±-	FINISH	WEIGHT -	REV B
MATERIAL SEE NOTES material_2	FINISH SEE NOTES finish_spec_2	CUSTOMER DRAWING	A200779 C-2170826	

THIS DRAWING IS UNPUBLISHED. RELEASED FOR PUBLICATION 20
 © COPYRIGHT 20 BY - ALL RIGHTS RESERVED.

LOC		DIST		REVISIONS			
P	LTR	DESCRIPTION	DATE	DWN	APVD		
-	-	SEE SHEET 1	-	-	-		

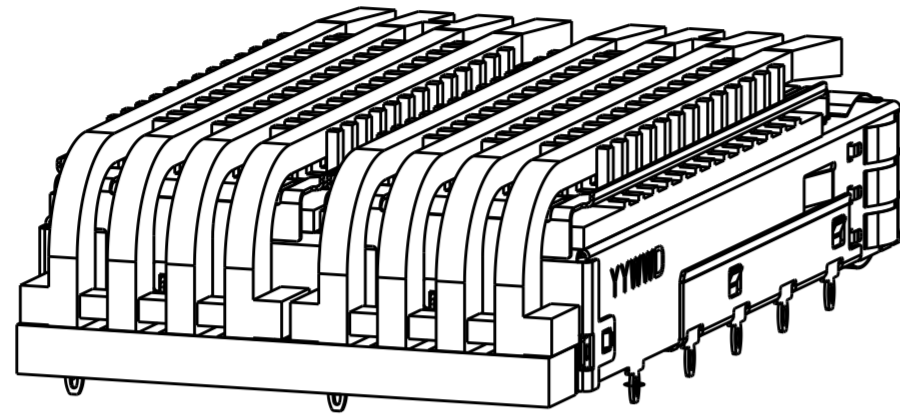

2170826-1 AS SHOWN
SCALE 2:1

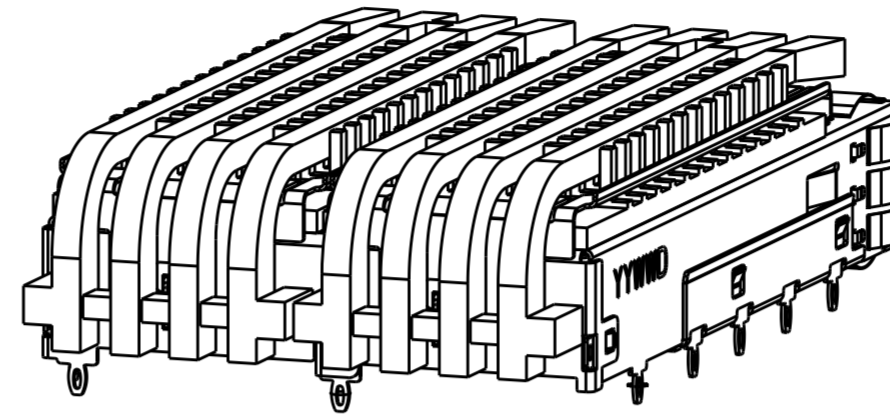

2170826-2 AS SHOWN
SAME AS 2170826-1 EXCEPT FOR WITHOUT ORGANIZER
SCALE 2:1

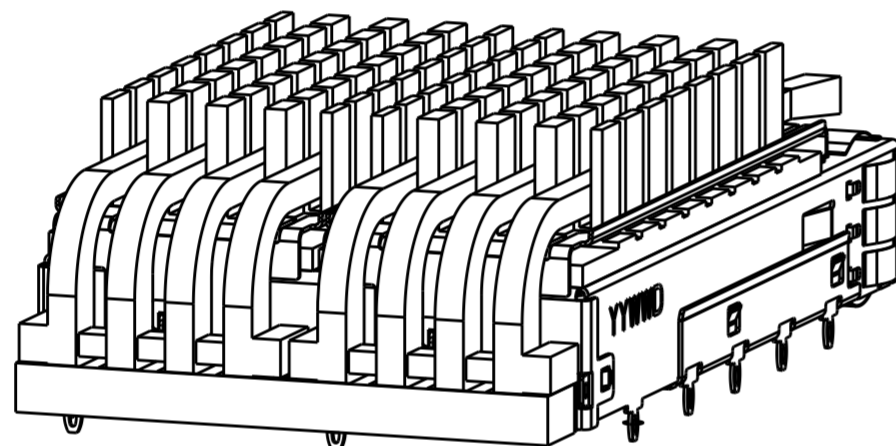

2170826-3 AS SHOWN
SCALE 2:1

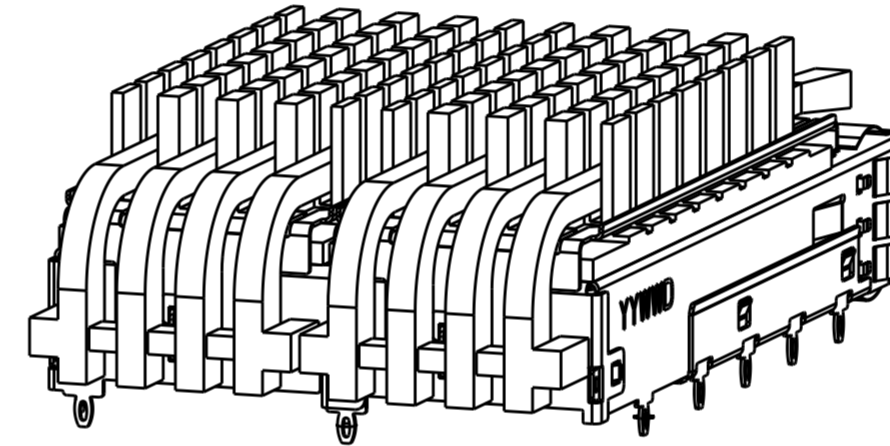

2170826-4 AS SHOWN
SAME AS 2170826-3 EXCEPT FOR WITHOUT ORGANIZER
SCALE 2:1

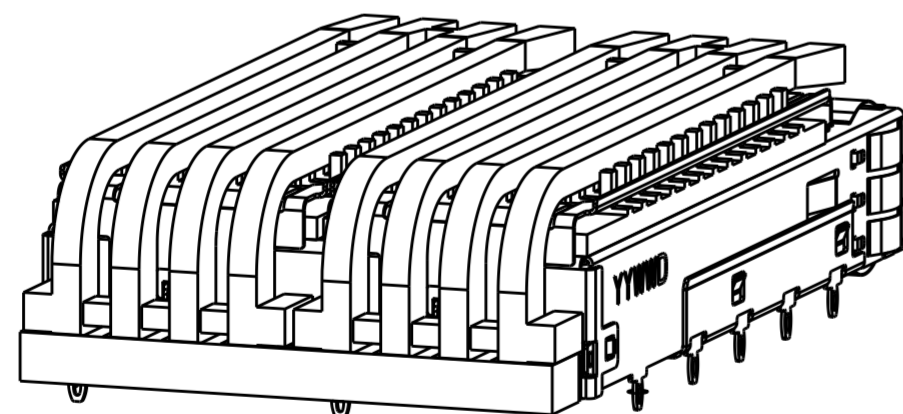

2170826-5 AS SHOWN
SAME AS 2170826-1 EXCEPT FOR HEAT SINK
SCALE 2:1

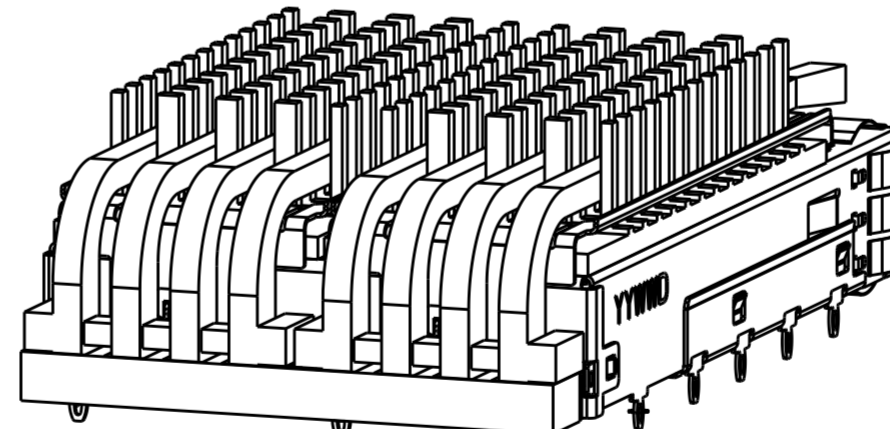

2170826-6 AS SHOWN
SAME AS 2170826-1 EXCEPT FOR HEAT SINK
SCALE 2:1

THIS DRAWING IS A CONTROLLED DOCUMENT.		DWN BING LIU 16SEP2014	 TE Connectivity
		CHK JASON YANG 16SEP2014	
		APVD - 01NOV2016	NAME RECEPTACLE CAGE ASSEMBLY WITH HEAT SINKS AND LIGHT PIPES, THRU BEZEL, 1X2, QSFP28, SPRING
DIMENSIONS: mm		PRODUCT SPEC 108-19428	SIZE A200779
TOLERANCES UNLESS OTHERWISE SPECIFIED: 0 PLC ± 1 PLC ±0.25 2 PLC ±0.2 3 PLC ± 4 PLC ± ANGLES ±		APPLICATION SPEC 114-32023	CAGE CODE C-2170826
MATERIAL SEE NOTES material_2		FINISH SEE NOTES finish_spec_2	DRAWING NO C-2170826
		WEIGHT -	RESTRICTED TO -
		CUSTOMER DRAWING	SCALE 3:1 SHEET 5 OF 10 REV B

THIS DRAWING IS UNPUBLISHED. RELEASED FOR PUBLICATION 20
 © COPYRIGHT 20 BY - ALL RIGHTS RESERVED.

LOC		DIST		REVISIONS			
P	LTR	DESCRIPTION	DATE	DWN	APVD		
-	-	SEE SHEET 1	-	-	-		

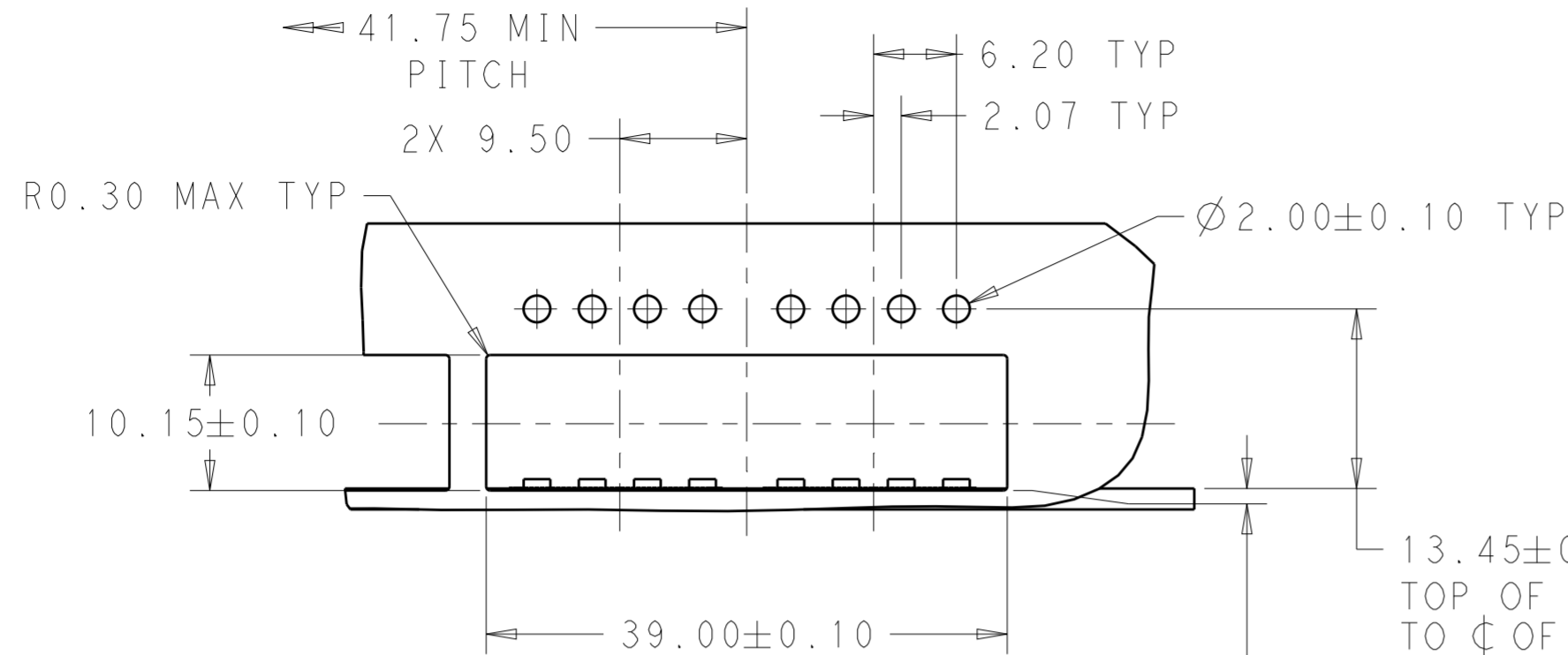

CAGE ASSEMBLY IS OMITED

13.45±0.10
TOP OF PCB
TO ϕ OF LIGHT PIPES
0.15±0.10
(BOTTOM OF
CUT-OUT IN BEZEL
TO TOP PCB)

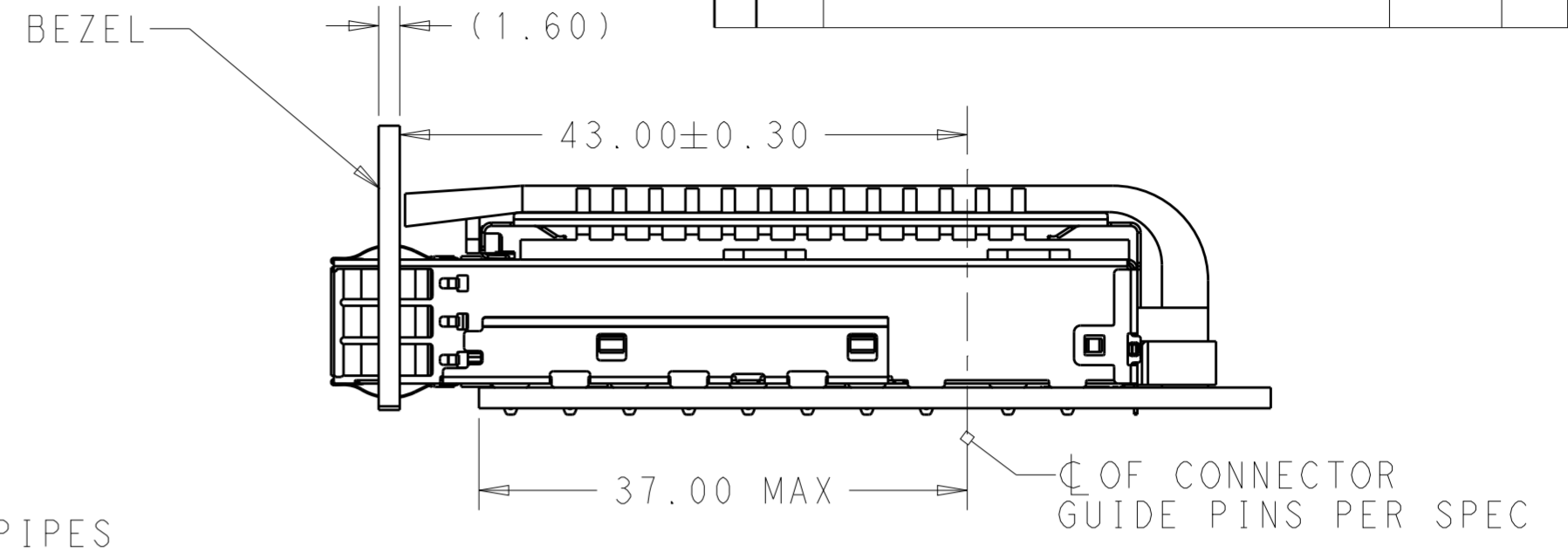

SINGLE SIDE MOUNTING
SCALE 2:1

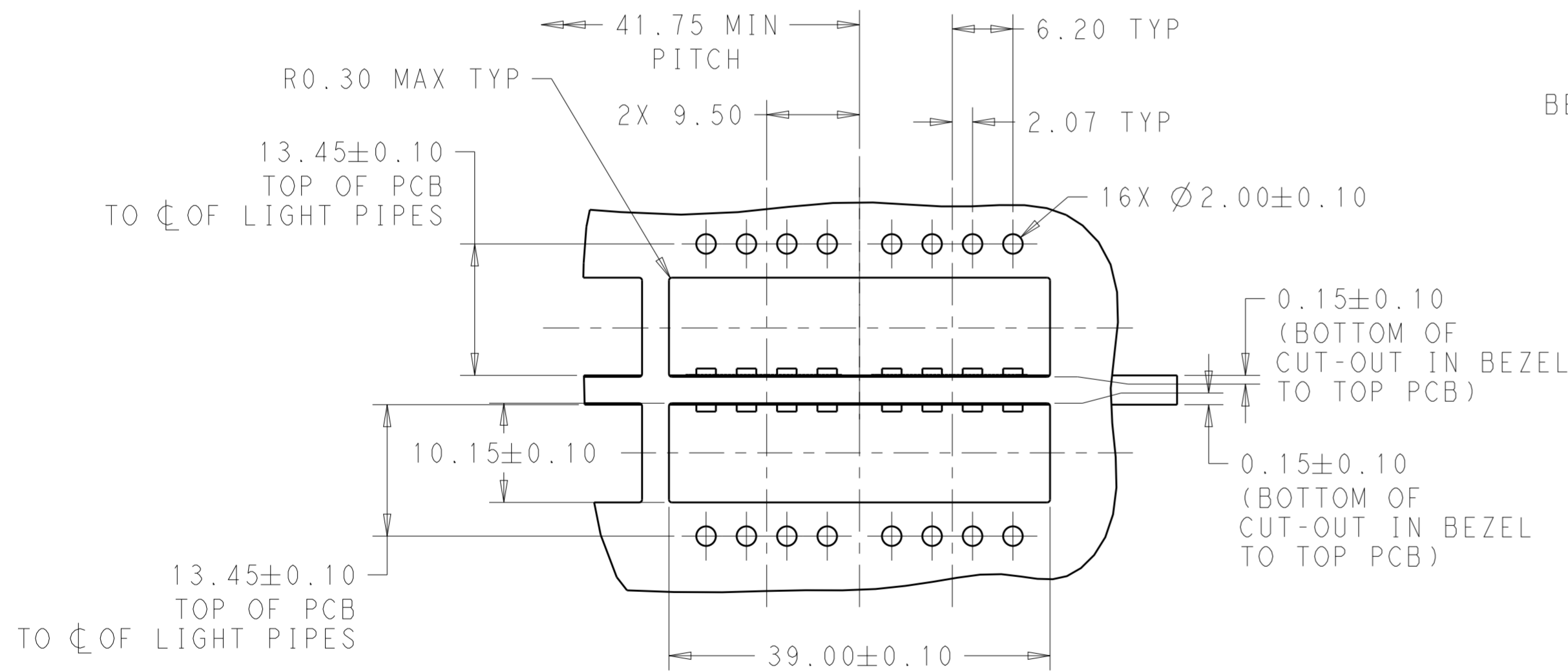

CAGE ASSEMBLY IS OMITED

13.45±0.10
TOP OF PCB
TO ϕ OF LIGHT PIPES
0.15±0.10
(BOTTOM OF
CUT-OUT IN BEZEL
TO TOP PCB)
0.15±0.10
(BOTTOM OF
CUT-OUT IN BEZEL
TO TOP PCB)

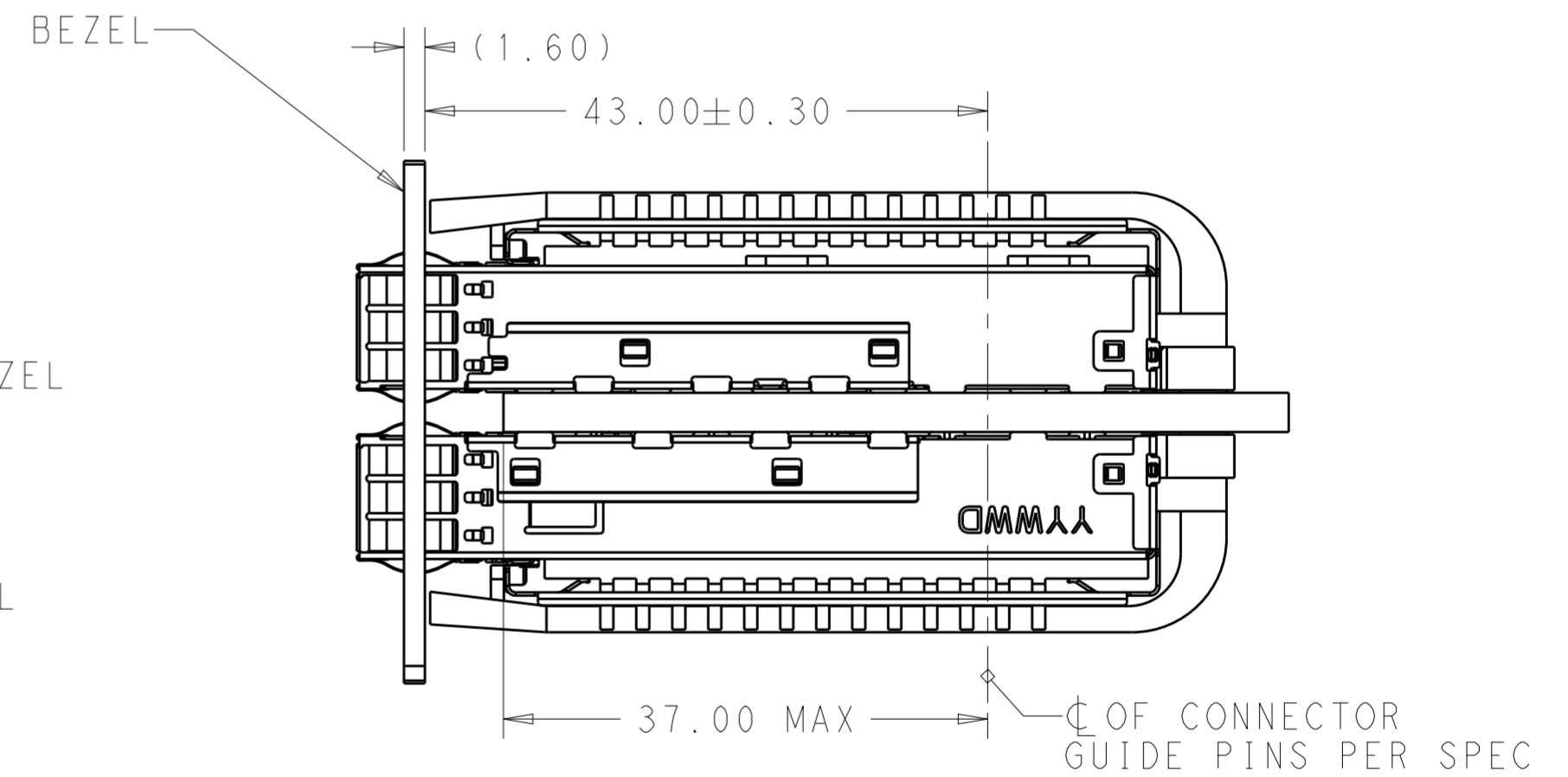

BELLY TO BELLY MOUNTING
SCALE 2:1

THIS DRAWING IS A CONTROLLED DOCUMENT.		DWN BING LIU 16SEP2014	 TE Connectivity	
		CHK JASON YANG 16SEP2014		
DIMENSIONS: mm		APVD 01NOV2016	NAME RECEPTACLE CAGE ASSEMBLY WITH HEAT SINKS AND LIGHT PIPES, THRU BEZEL, 1X2, QSFP28, SPRING	
TOLERANCES UNLESS OTHERWISE SPECIFIED: 0 PLC ± 1 PLC ±0.25 2 PLC ±0.2 3 PLC ± 4 PLC ± ANGLES ± FINISH		PRODUCT SPEC 108-19428	SIZE A200779	
MATERIAL SEE NOTES material_2		APPLICATION SPEC 114-32023	DRAWING NO C-2170826	
		WEIGHT -	RESTRICTED TO -	
		CUSTOMER DRAWING	SCALE 3:1 SHEET 6 OF 10 REV B	

THIS DRAWING IS UNPUBLISHED. RELEASED FOR PUBLICATION 20
 © COPYRIGHT 20 BY - ALL RIGHTS RESERVED.

LOC	DIST	REVISIONS			
P	LTR	DESCRIPTION	DATE	DWN	APVD
-	-	SEE SHEET 1	-	-	-

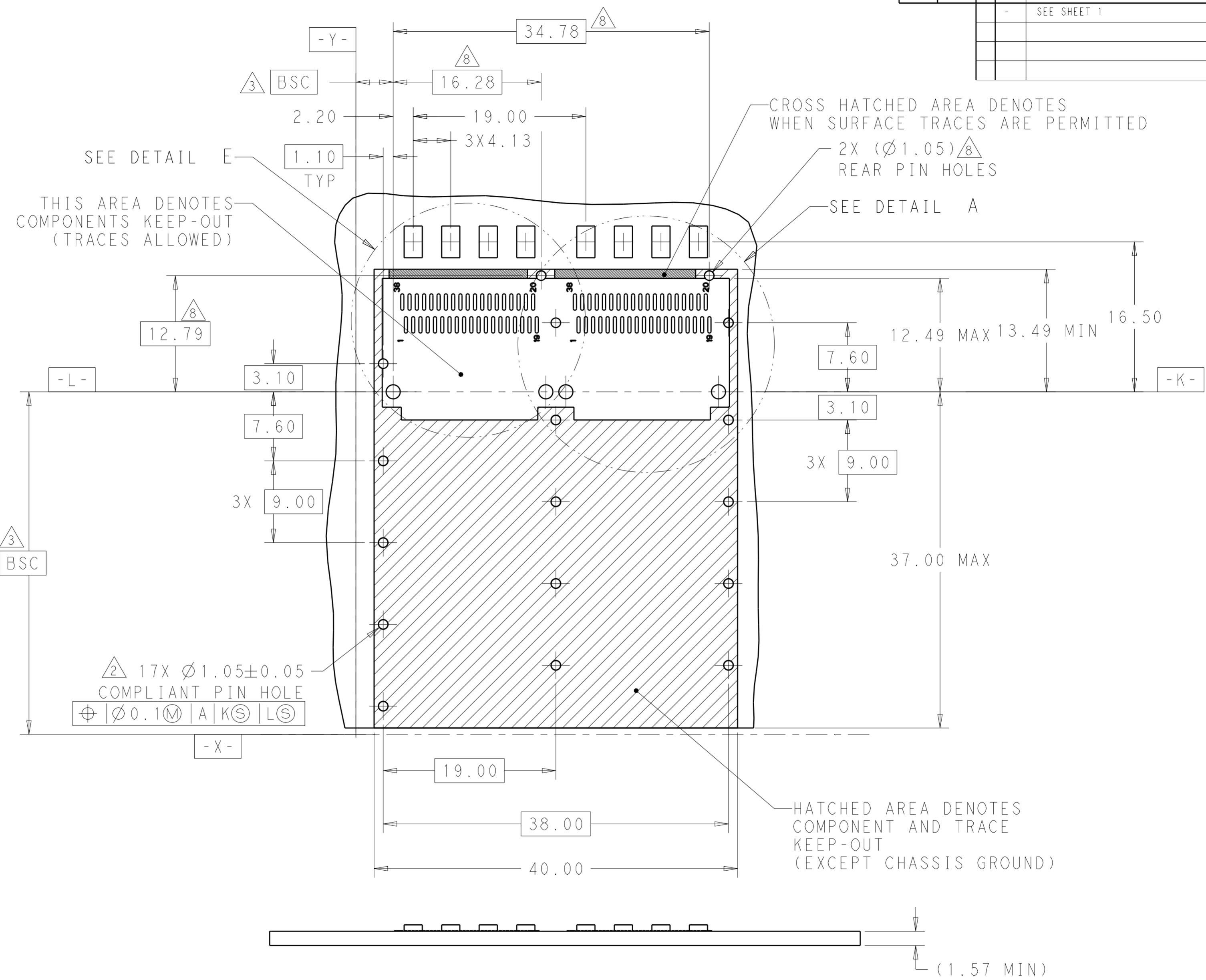

2 17X Ø1.05±0.05
 COMPLIANT PIN HOLE
 Ø0.1M | A | K | L | S

RECOMMENDED PCB LAYOUT
 SINGLE TYPE
 PCB TOLERANCE: ±0.05
 SCALE 3:1

THIS DRAWING IS A CONTROLLED DOCUMENT.		DWN BING LIU 16SEP2014	TE Connectivity	
		CHK JASON YANG 16SEP2014		
		APVD - 01NOV2016	NAME RECEPTACLE CAGE ASSEMBLY WITH HEAT SINKS AND LIGHT PIPES, THRU BEZEL, 1X2, QSFP28, SPRING	
DIMENSIONS: mm		PRODUCT SPEC 108-19428	SIZE A2	CAGE CODE 00779
TOLERANCES UNLESS OTHERWISE SPECIFIED: 0 PLC ±- 1 PLC ±0.25 2 PLC ±0.2 3 PLC ±- 4 PLC ±- ANGLES ±- FINISH SEE NOTES		APPLICATION SPEC 114-32023	DRAWING NO C-2170826	RESTRICTED TO -
MATERIAL SEE NOTES material_2		WEIGHT -	SCALE 3:1 SHEET 7 OF 10 REV B	
		CUSTOMER DRAWING		

THIS DRAWING IS UNPUBLISHED. RELEASED FOR PUBLICATION 20
 © COPYRIGHT 20 BY - ALL RIGHTS RESERVED.

LOC	DIST	REVISIONS			
P	LTR	DESCRIPTION	DATE	DWN	APVD
-	-	SEE SHEET 1	-	-	-

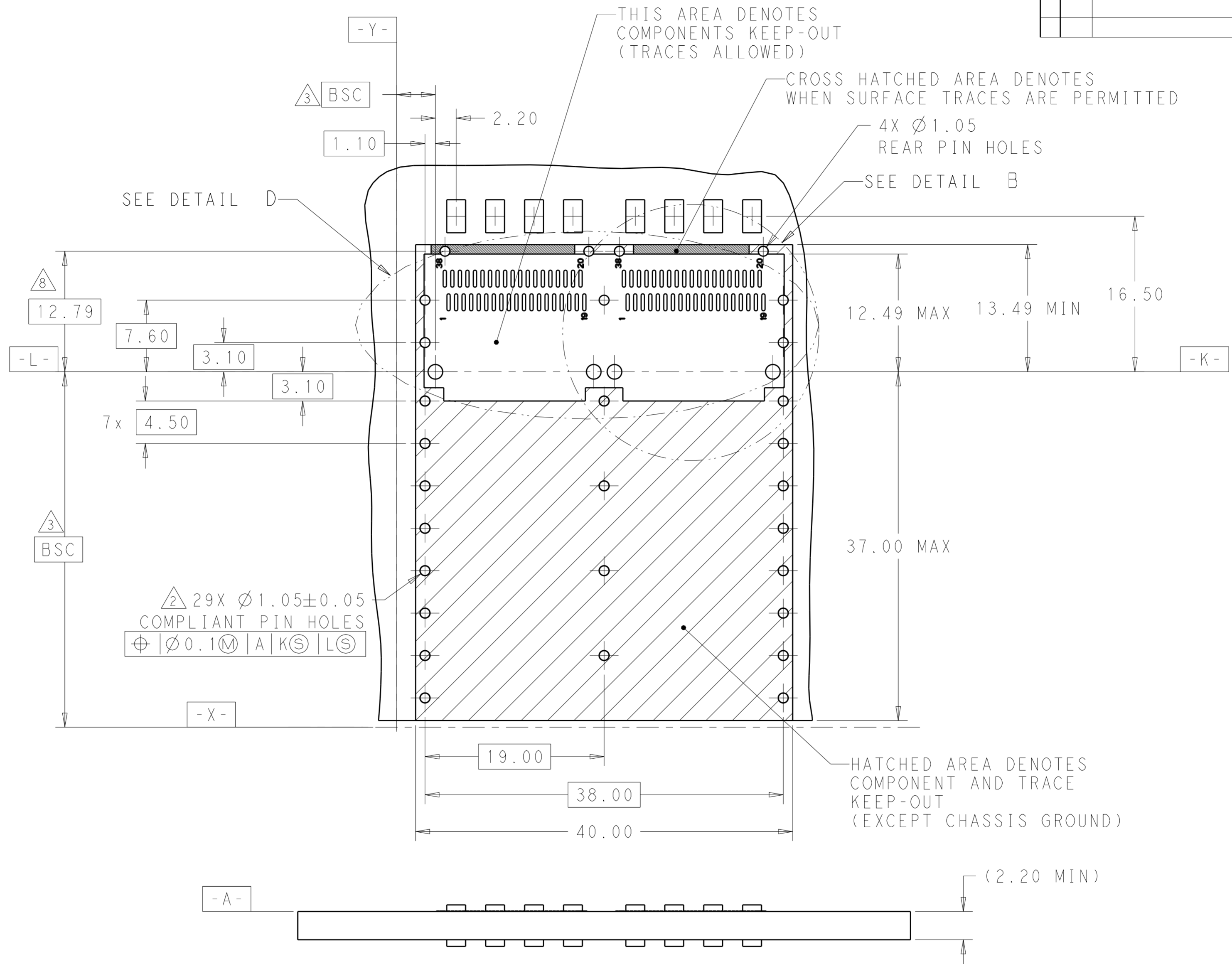

RECOMMENDED PCB LAYOUT
 BELLY TO BELLY TYPE
 PCB TOLERANCE: ±0.05
 SCALE 3:1

THIS DRAWING IS A CONTROLLED DOCUMENT.		DWN BING LIU 16SEP2014	TE Connectivity
DIMENSIONS: mm		CHK JASON YANG 16SEP2014	
		APVD 01NOV2016	
TOLERANCES UNLESS OTHERWISE SPECIFIED:		PRODUCT SPEC 108-19428	NAME RECEPTACLE CAGE ASSEMBLY WITH HEAT SINKS AND LIGHT PIPES, THRU BEZEL, 1X2, QSFP28, SPRING
0 PLC ±		APPLICATION SPEC 114-32023	SIZE A200779
1 PLC ±0.25		WEIGHT -	DRAWING NO C-2170826
2 PLC ±0.2		CUSTOMER DRAWING	RESTRICTED TO -
3 PLC ±		SCALE 3:1	SHEET 8 OF 10
4 PLC ±			REV B
ANGLES ±			
FINISH SEE NOTES			
MATERIAL SEE NOTES			
material_2			
finish_spec_2			

THIS DRAWING IS UNPUBLISHED. RELEASED FOR PUBLICATION 20
 © COPYRIGHT 20 BY - ALL RIGHTS RESERVED.

LOC		DIST		REVISIONS			
P	LTR	DESCRIPTION		DATE	DWN	APVD	
-	-	SEE SHEET 1		-	-	-	

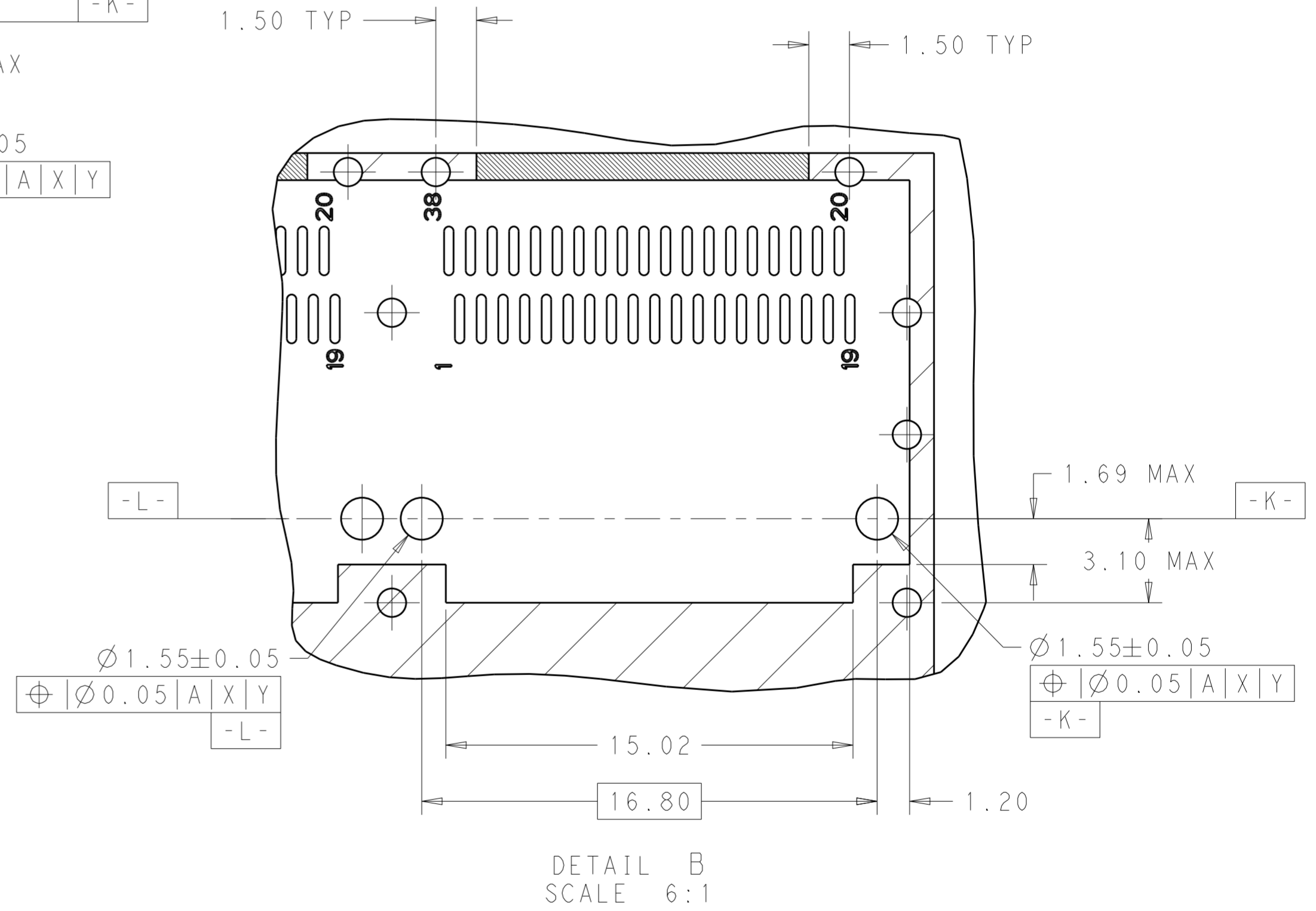
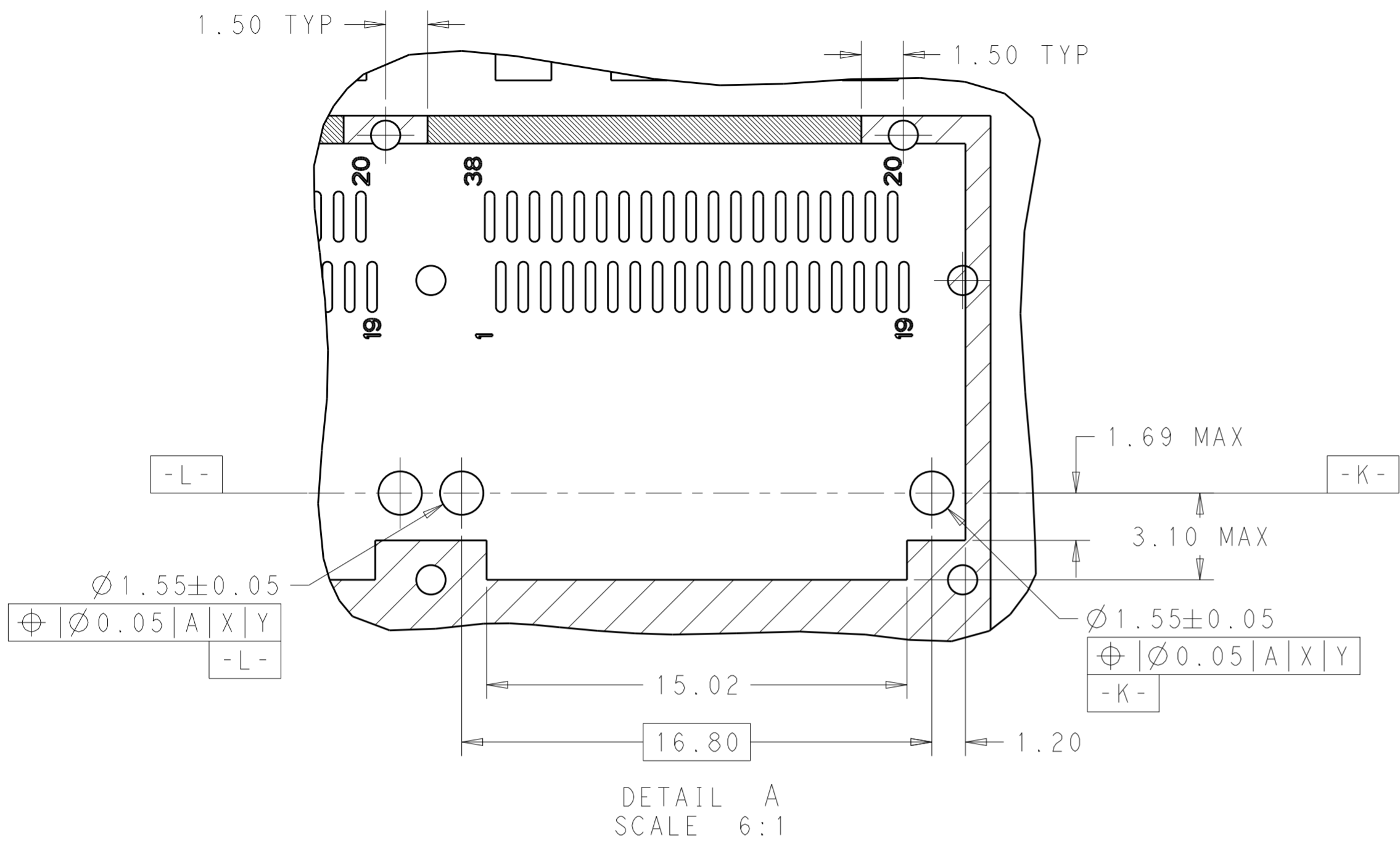

THIS DRAWING IS A CONTROLLED DOCUMENT.		DWN BING LIU 16SEP2014	STE TE Connectivity
		CHK JASON YANG 16SEP2014	
		APVD - 01NOV2016	NAME RECEPTACLE CAGE ASSEMBLY WITH HEAT SINKS AND LIGHT PIPES, THRU BEZEL, 1X2, QSFP28, SPRING
DIMENSIONS: mm		PRODUCT SPEC 108-19428	SIZE A200779
TOLERANCES UNLESS OTHERWISE SPECIFIED: 0 PLC ± 1 PLC ±0.25 2 PLC ±0.2 3 PLC ± 4 PLC ± ANGLES ±		APPLICATION SPEC 114-32023	DRAWING NO C-2170826
MATERIAL SEE NOTES material_2		FINISH SEE NOTES finish_spec_2	RESTRICTED TO -
		WEIGHT -	SCALE 3:1 SHEET 9 OF 10 REV B
		CUSTOMER DRAWING	

THIS DRAWING IS UNPUBLISHED. RELEASED FOR PUBLICATION 20
 © COPYRIGHT 20 BY - ALL RIGHTS RESERVED.

LOC		DIST		REVISIONS			
P	LTR	DESCRIPTION	DATE	DWN	APVD		
-	-	SEE SHEET 1	-	-	-		

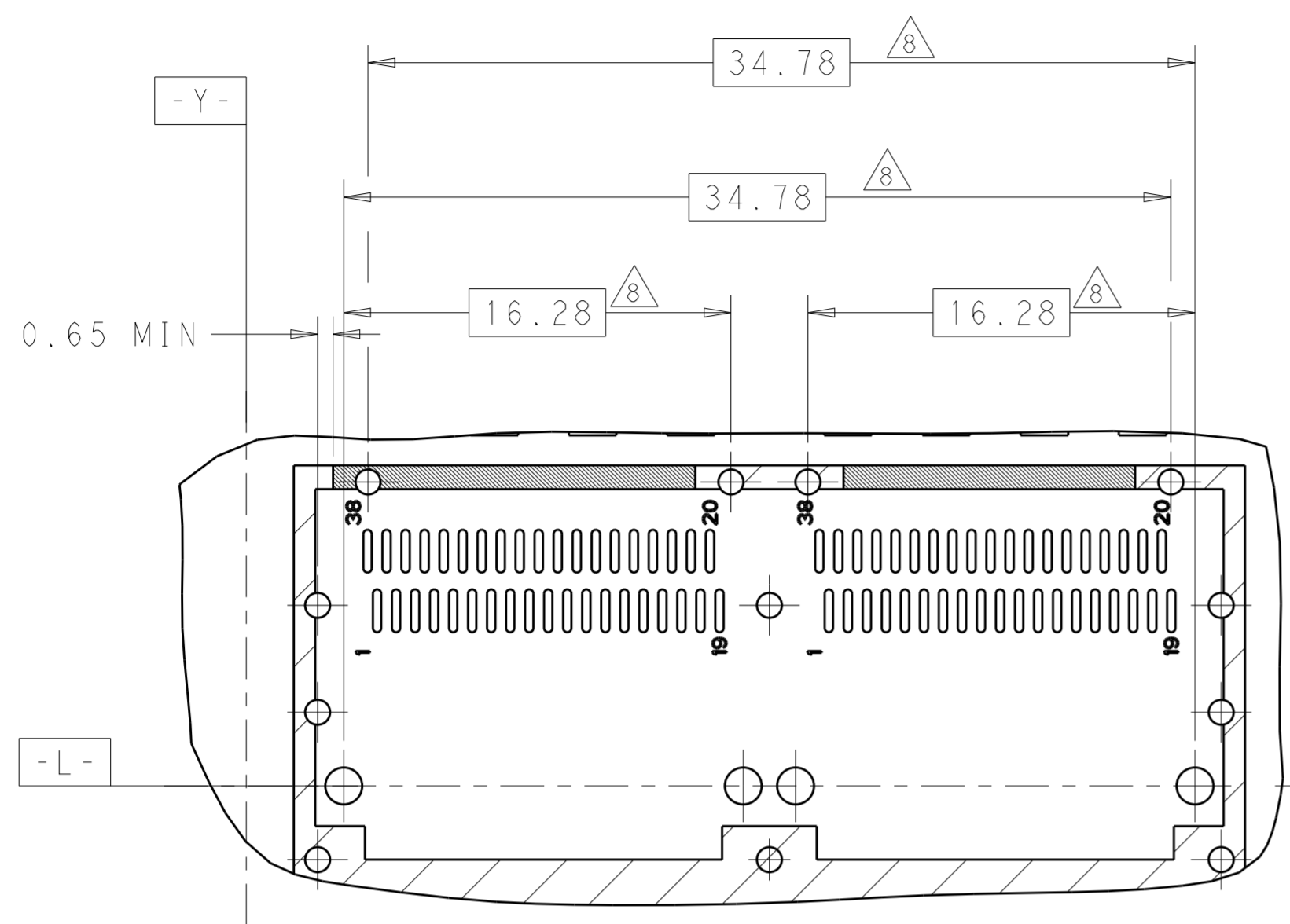

DETAIL D
SCALE 4:1

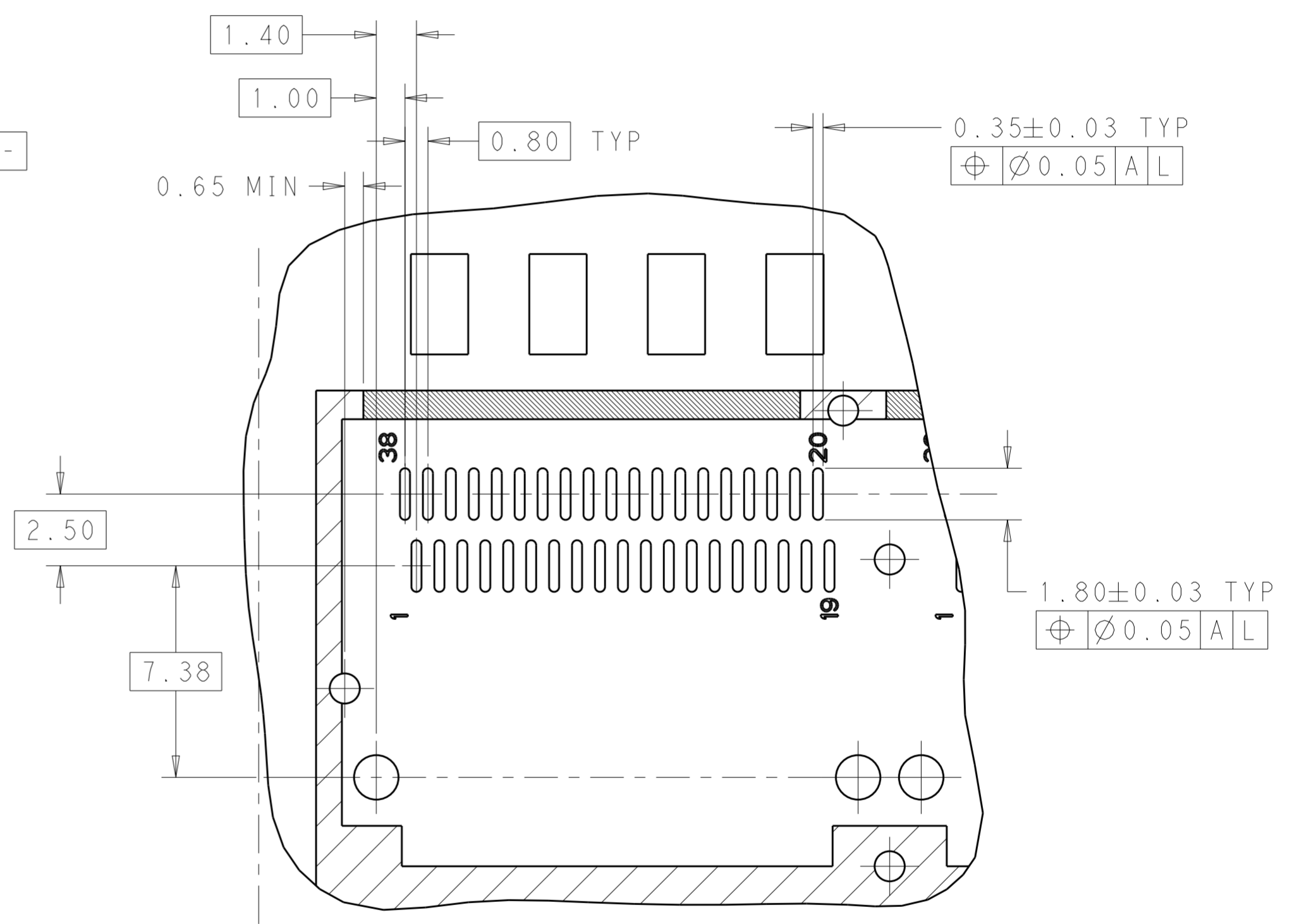

DETAIL E
SCALE 6:1

THIS DRAWING IS A CONTROLLED DOCUMENT.		DWN BING LIU 16SEP2014	STE TE Connectivity
		CHK JASON YANG 16SEP2014	
		APVD - 01NOV2016	NAME RECEPTACLE CAGE ASSEMBLY WITH HEAT SINKS AND LIGHT PIPES, THRU BEZEL, 1X2, QSFP28, SPRING
DIMENSIONS: mm		PRODUCT SPEC 108-19428	SIZE A200779
TOLERANCES UNLESS OTHERWISE SPECIFIED: 0 PLC ± 1 PLC ±0.25 2 PLC ±0.2 3 PLC ± 4 PLC ± ANGLES ±		APPLICATION SPEC 114-32023	CAGE CODE C-2170826
MATERIAL SEE NOTES material_2		FINISH SEE NOTES finish_spec_2	DRAWING NO. G-2170826
		WEIGHT -	RESTRICTED TO -
		CUSTOMER DRAWING	SCALE 3:1 SHEET 10 OF 10 REV B