



Chipsmall Limited consists of a professional team with an average of over 10 year of expertise in the distribution of electronic components. Based in Hongkong, we have already established firm and mutual-benefit business relationships with customers from,Europe,America and south Asia,supplying obsolete and hard-to-find components to meet their specific needs.

With the principle of “Quality Parts,Customers Priority,Honest Operation,and Considerate Service”,our business mainly focus on the distribution of electronic components. Line cards we deal with include Microchip,ALPS,ROHM,Xilinx,Pulse,ON,Everlight and Freescale. Main products comprise IC,Modules,Potentiometer,IC Socket,Relay,Connector.Our parts cover such applications as commercial,industrial, and automotives areas.

We are looking forward to setting up business relationship with you and hope to provide you with the best service and solution. Let us make a better world for our industry!



Contact us

Tel: +86-755-8981 8866 Fax: +86-755-8427 6832

Email & Skype: info@chipsmall.com Web: www.chipsmall.com

Address: A1208, Overseas Decoration Building, #122 Zhenhua RD., Futian, Shenzhen, China





2183 Aerial Hanger Kit

August 2000
78-8130-2365-8-A

Important Notice

Before using this product, you must evaluate it and determine if it is suitable for your intended application. You assume all risks and liability associated with such use.

Warranty; Limited Remedy; Limited Liability. This product will be free from defects in material and manufacture as of the date of purchase. **3M MAKES NO OTHER WARRANTIES INCLUDING, BUT NOT LIMITED TO, ANY IMPLIED WARRANTY OF MERCHANTABILITY OR FITNESS FOR A PARTICULAR PURPOSE.** If this product is defective within the warranty period stated above, your exclusive remedy shall be, at 3M's option, to replace or repair the 3M product or refund the purchase price of the 3M product. **Except where prohibited by law, 3M will not be liable for any loss or damage arising from this 3M product, whether direct, indirect, special, incidental or consequential regardless of the legal theory asserted.**



Telecommunications

6801 River Place Blvd.
Austin, TX 78726-9000
800/426-8688
www.3M.com/telecom

Litho in USA
© 3M IPC 2000 78-8130-2365-8-A

1.0 General

3M™ 2183 Aerial Hanger Kit is used with the 3M™ 2178 Fiber Optic Splice Case for aerial applications. The 2183 Kit will also accommodate the 2178 Splice Case with one or two 3M™ 2181 Cable Addition Kits.

2.0 Grounding

If required, bond braid is connected between aerial hanger and either ground stud on splice case. Secure bond braid before aerial hanger is installed on splice case.



3.0 Aerial Hanger Bracket Installation

- 3.1 Remove corner inserts on the strand side by tapping each insert on the back of the 2178 base.

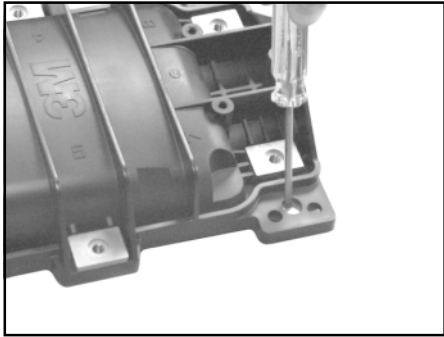

- 3.2 Install both 2183 corner inserts with the bolts facing the closure bottom.

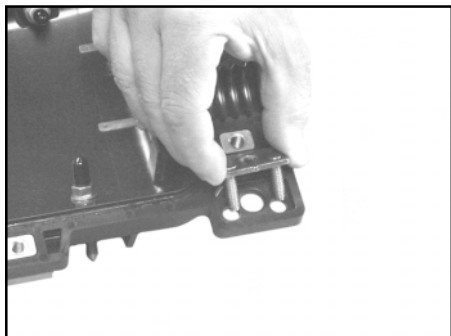

- 3.3 Fasten the hanger bracket to the insert with the nuts provided. Torque nuts to 100 inch pounds (1130 cm • N) to secure hanger.

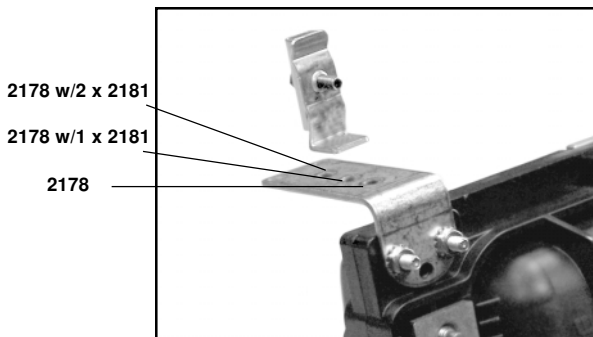

- 3.4 Offset position - Used when hanging the 2178 Splice Case below one or more existing cables.

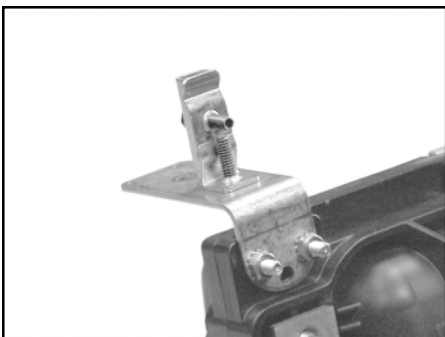

4.0 Hanger Bracket

- 4.1 Different sized strand may be accommodated when securing bracket by rotating notched caps.

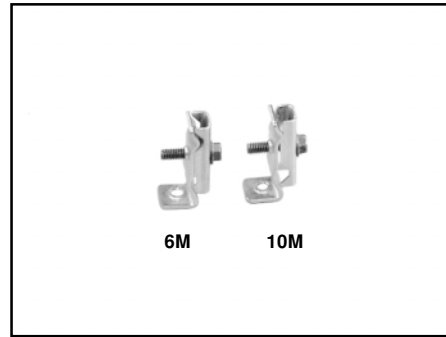

- 4.2 Secure closure to strand using proper position at bottom of external bonding/hanger bracket. (Strand is always placed in lower position of bracket).

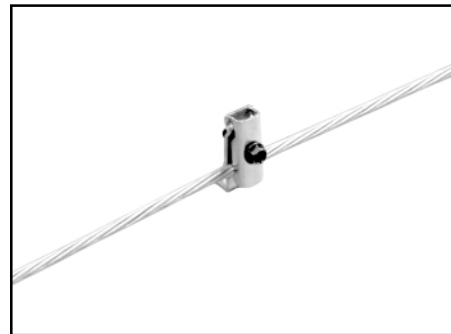

- 4.3 Tighten bolt in external bonding/hanger bracket to approximately 50 inch pounds (565 cm • N) to secure hanger. For self-supporting cable tighten to 75 inch pounds (850 cm • N) to secure hanger.