



Chipsmall Limited consists of a professional team with an average of over 10 year of expertise in the distribution of electronic components. Based in Hongkong, we have already established firm and mutual-benefit business relationships with customers from,Europe,America and south Asia,supplying obsolete and hard-to-find components to meet their specific needs.

With the principle of “Quality Parts,Customers Priority,Honest Operation,and Considerate Service”,our business mainly focus on the distribution of electronic components. Line cards we deal with include Microchip,ALPS,ROHM,Xilinx,Pulse,ON,Everlight and Freescale. Main products comprise IC,Modules,Potentiometer,IC Socket,Relay,Connector.Our parts cover such applications as commercial,industrial, and automotives areas.

We are looking forward to setting up business relationship with you and hope to provide you with the best service and solution. Let us make a better world for our industry!



Contact us

Tel: +86-755-8981 8866 Fax: +86-755-8427 6832

Email & Skype: info@chipsmall.com Web: www.chipsmall.com

Address: A1208, Overseas Decoration Building, #122 Zhenhua RD., Futian, Shenzhen, China



Components of electronic housing - UM-PRO LID-73N BK - 2200174

Please be informed that the data shown in this PDF Document is generated from our Online Catalog. Please find the complete data in the user's documentation. Our General Terms of Use for Downloads are valid (<http://phoenixcontact.com/download>)

Panel mounting base, Color: black



Product Features

- ✓ Plug-in assembly reduces assembly time and therefore saves costs
- ✓ Mounting close to the edge provides wiring advantages
- ✓ Freely positionable covers offer flexibility
- ✓ Additional foot elements increase mechanical stability
- ✓ PE contacts that can be fitted on both sides ensure safety
- ✓ Additional labeling of PCB with Phoenix Contact PMB module marker carrier (drill hole diameter 4 mm)
- ✓ Temperature range up to 100°C extends the possible fields of application (UM-PRO)
- ✓ Well-designed profile geometry increases the form stability
- ✓ Device communication can be extended by BUS cross contacting
- ✓ Labeling area for standard SK strips or TML marking foil (max. height 6 mm)



Key commercial data

| | |
|--------------------------------------|----------|
| Packing unit | 1 pc |
| Minimum order quantity | 10 pc |
| Weight per Piece (excluding packing) | 8.0 GRM |
| Custom tariff number | 39269097 |
| Country of origin | Poland |

Technical data

General

| | |
|------------------|---------------------|
| Housing type | Panel mounting base |
| Housing material | Polyamide |
| Color | black |

Components of electronic housing - UM-PRO LID-73N BK - 2200174

Classifications

eCl@ss

| | |
|------------|----------|
| eCl@ss 4.0 | 27180401 |
| eCl@ss 4.1 | 27180401 |
| eCl@ss 5.0 | 27180506 |
| eCl@ss 5.1 | 27180506 |
| eCl@ss 6.0 | 27400501 |
| eCl@ss 7.0 | 27182701 |
| eCl@ss 8.0 | 27182701 |

ETIM

| | |
|----------|----------|
| ETIM 3.0 | EC001031 |
| ETIM 4.0 | EC000482 |
| ETIM 5.0 | EC000721 |

UNSPSC

| | |
|---------------|----------|
| UNSPSC 6.01 | 31261501 |
| UNSPSC 7.0901 | 31261501 |
| UNSPSC 11 | 31261501 |
| UNSPSC 12.01 | 31261501 |
| UNSPSC 13.2 | 31261501 |

Approvals

Approvals

Approvals

UL Recognized

Ex Approvals

Approvals submitted

Approval details

| |
|---|
| UL Recognized  |
|---|

Components of electronic housing - UM-PRO LID-73N BK - 2200174

Drawings

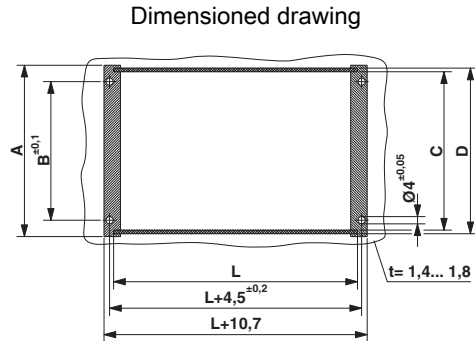

L = length of cover required; dimensions A=76 mm; B=58 mm; C=69 mm; D=73 mm