



Chipsmall Limited consists of a professional team with an average of over 10 year of expertise in the distribution of electronic components. Based in Hongkong, we have already established firm and mutual-benefit business relationships with customers from,Europe,America and south Asia,supplying obsolete and hard-to-find components to meet their specific needs.

With the principle of “Quality Parts,Customers Priority,Honest Operation,and Considerate Service”,our business mainly focus on the distribution of electronic components. Line cards we deal with include Microchip,ALPS,ROHM,Xilinx,Pulse,ON,Everlight and Freescale. Main products comprise IC,Modules,Potentiometer,IC Socket,Relay,Connector.Our parts cover such applications as commercial,industrial, and automotives areas.

We are looking forward to setting up business relationship with you and hope to provide you with the best service and solution. Let us make a better world for our industry!



Contact us

Tel: +86-755-8981 8866 Fax: +86-755-8427 6832

Email & Skype: info@chipsmall.com Web: www.chipsmall.com

Address: A1208, Overseas Decoration Building, #122 Zhenhua RD., Futian, Shenzhen, China



HOUSING UPPER PART: RPI HS BC 107,6

Assembly example
Overall dimensions complaint DIN 43880

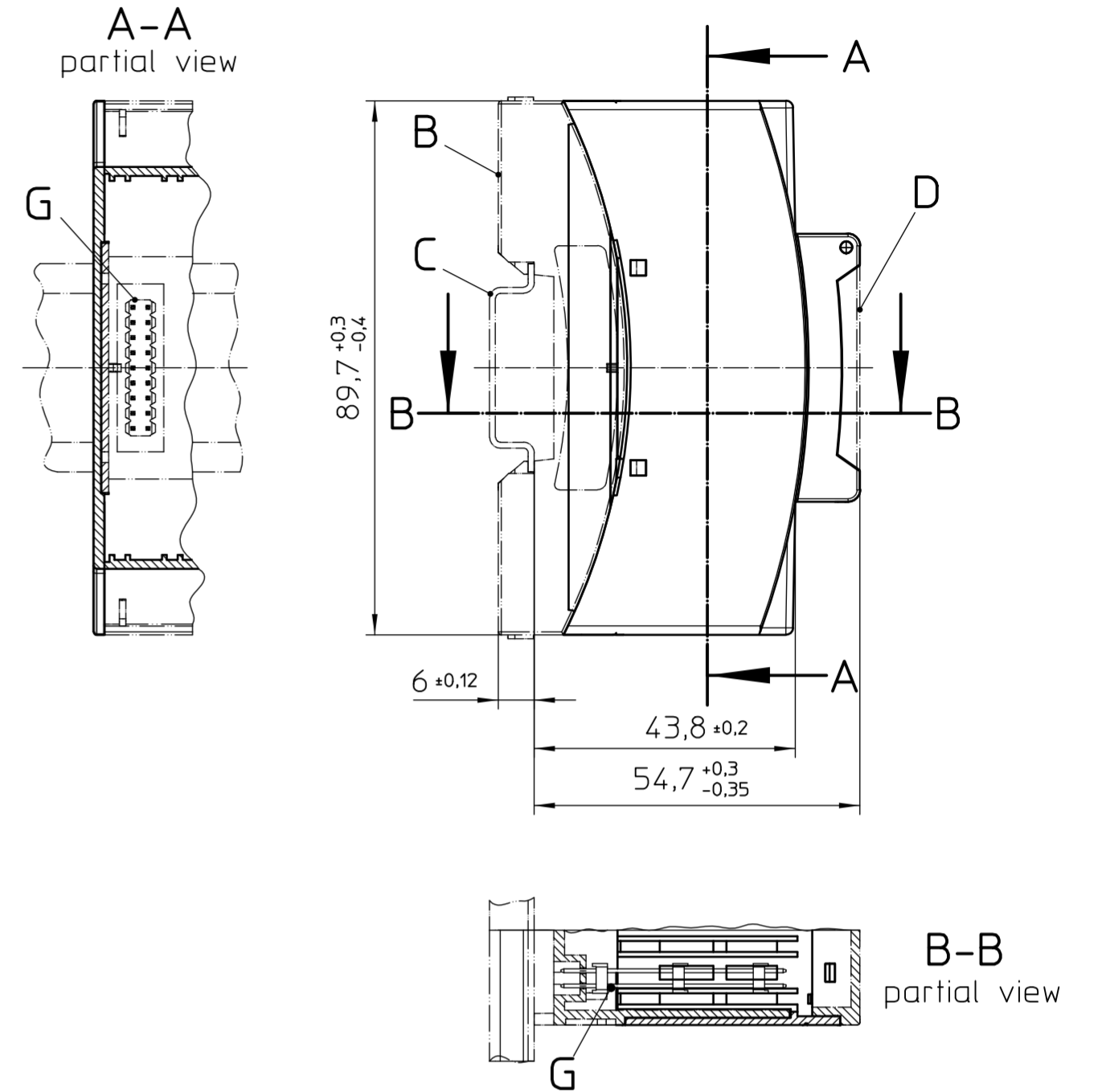
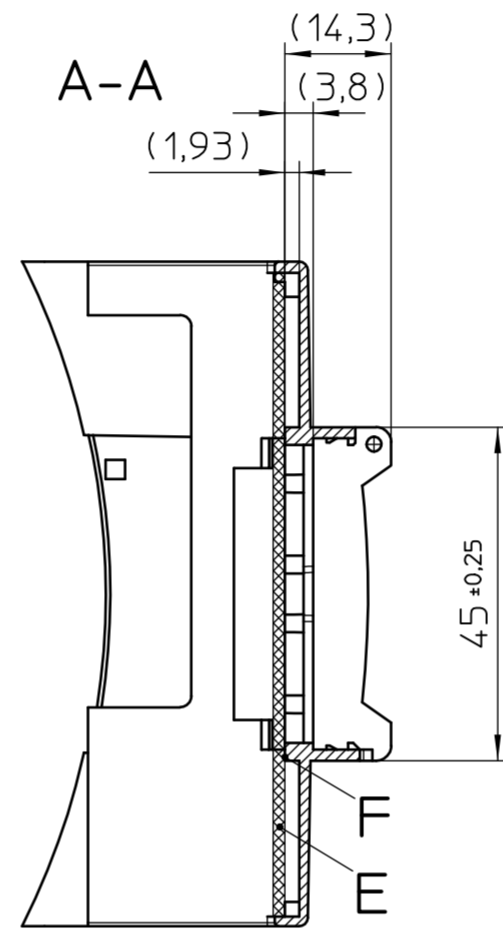
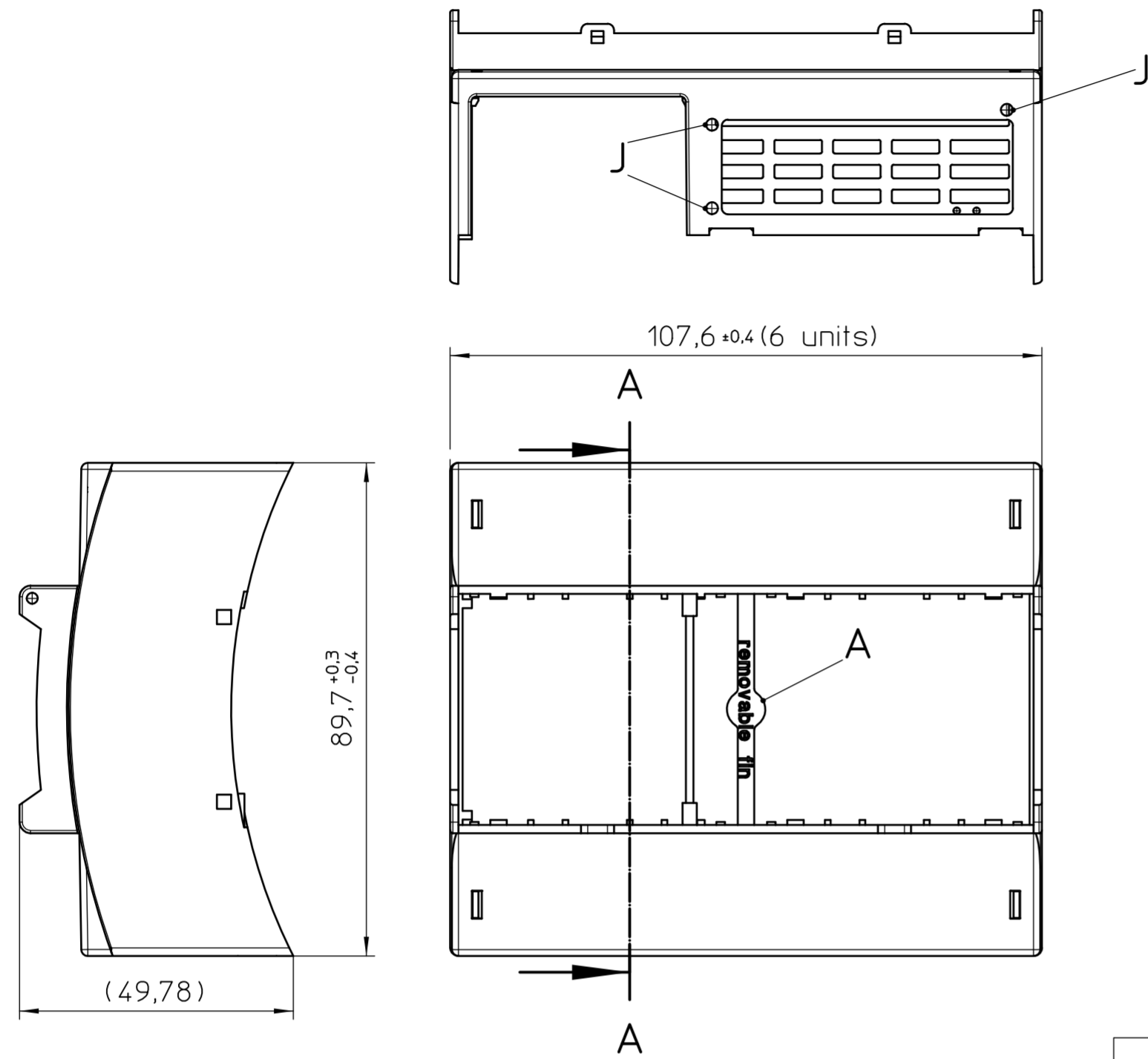

Transfer or duplication of this document as well as the utilisation or communication of its content are not permitted unless express consent is granted. Violations give rise to claims for damages. All rights reserved in case of patent, utility model or design patent registrations.

Weitergabe sowie Vervielfältigung dieses Dokuments, Verwertung und Mitteilung seines Inhalts sind verboten, soweit nicht ausdrücklich gestattet. Zuwiderhandlungen verpflichten zu Schadensersatz. Alle Rechte für den Fall der Patent-, Gebrauchsmuster- oder Designanmeldung vorbehalten.

PCB HOLDER

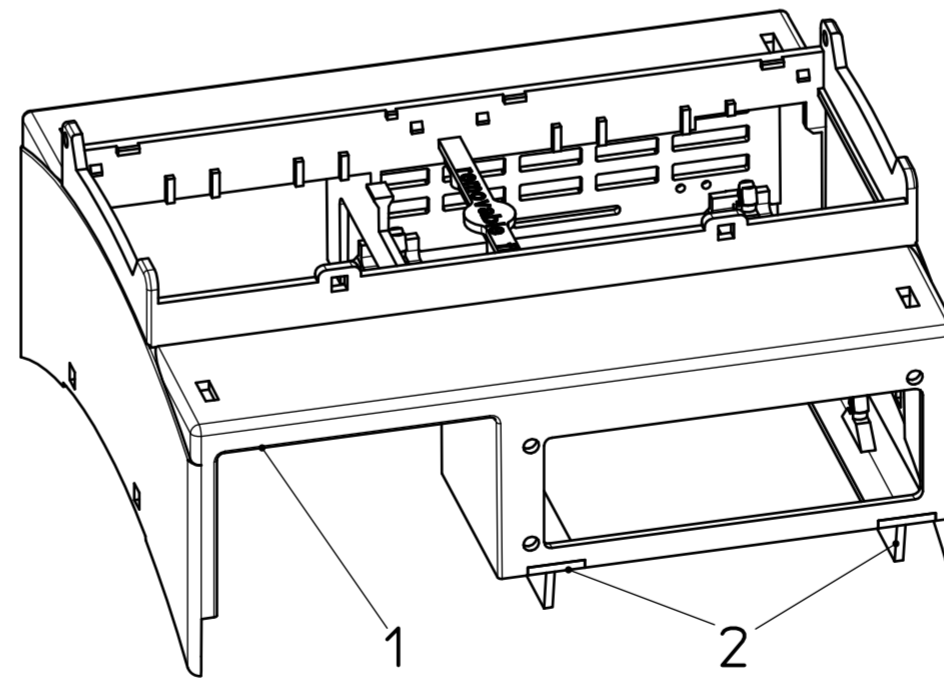
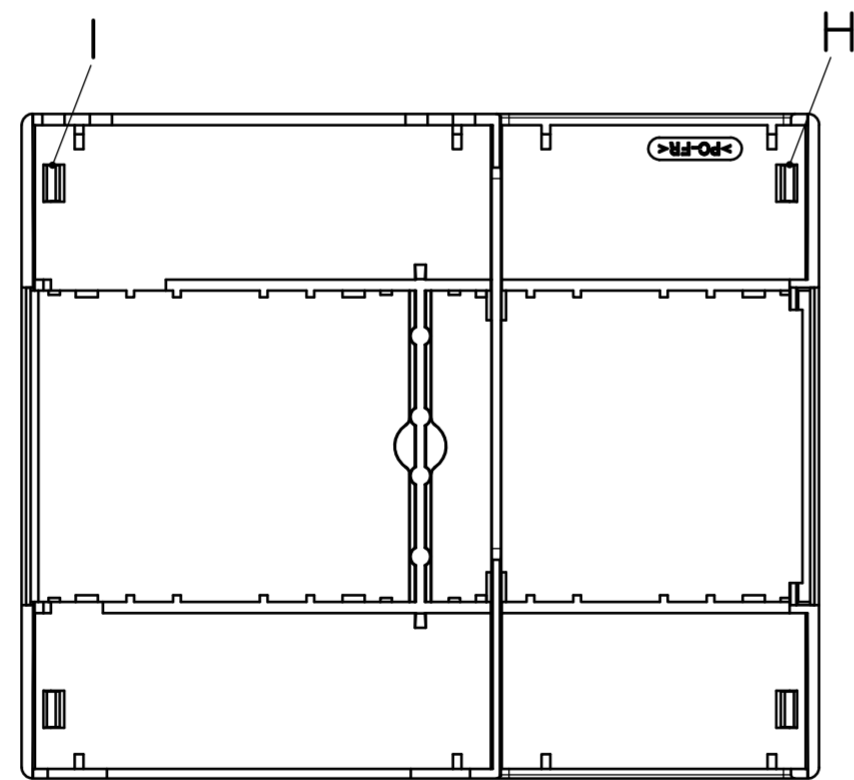
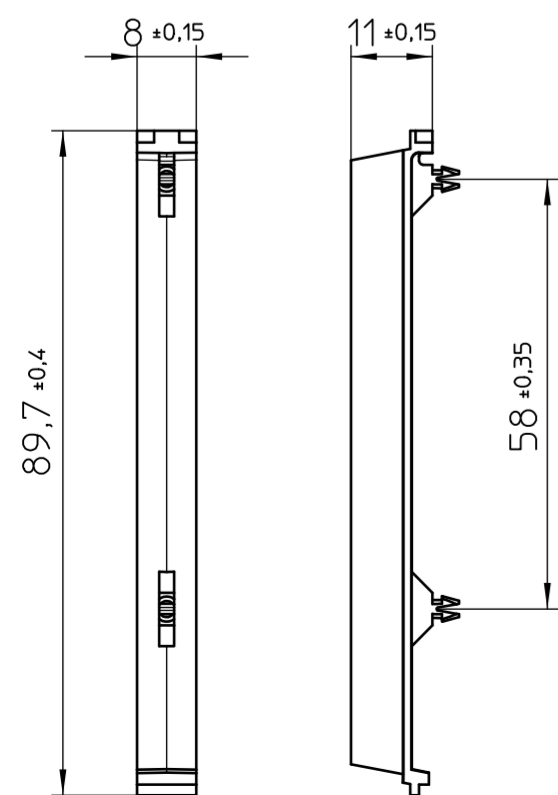

General Information:

- Simplified representation
- Document excluded from change process
- Linear dimensions [mm]
- Tolerances apply in a normale climate according to DIN 50014-23/50-2.
- Further information: www.phoenixcontact.com webcode: #0664

- A. Removeable fin
- B. Housing lower part (BC 107,6 UT HBUS)
- C. Mounting rail like EN 60715: TH 35-7,5 or mounting rail TH 35-15x1,5 similar to EN 60715
- D. Cover
- E. PCB
- F. Position PCB Ext and PCB Int
- G. Plug for HBUS (PSTD 0,65X0,65/18-3IS-2,54)
- H. Latching for PCB (RPI-BC EXT-PCB HBUS SET)
- I. Latching for PCB (RPI-BC INT-PCB SET)
- J. Mounting holes for RPI-BC A+-ADAPTER ATGY

KIT

RPI-BC 107,6 DEV-KIT P10

Pos.	QTY	Description
1	1	HOUSING UPPER PART
2	2	PCB Holder

DIN A2	document-No. / RI 00911685 / 01	date 11.02.2016	scale 1:1
	ident.-No. 2202875	document-type Customer drawing	
page 1 of 1	description RPI-BC 107,6 DEV-KIT KMGY P10		