



Chipsmall Limited consists of a professional team with an average of over 10 year of expertise in the distribution of electronic components. Based in Hongkong, we have already established firm and mutual-benefit business relationships with customers from,Europe,America and south Asia,supplying obsolete and hard-to-find components to meet their specific needs.

With the principle of “Quality Parts,Customers Priority,Honest Operation,and Considerate Service”,our business mainly focus on the distribution of electronic components. Line cards we deal with include Microchip,ALPS,ROHM,Xilinx,Pulse,ON,Everlight and Freescale. Main products comprise IC,Modules,Potentiometer,IC Socket,Relay,Connector.Our parts cover such applications as commercial,industrial, and automotives areas.

We are looking forward to setting up business relationship with you and hope to provide you with the best service and solution. Let us make a better world for our industry!



Contact us

Tel: +86-755-8981 8866 Fax: +86-755-8427 6832

Email & Skype: info@chipsmall.com Web: www.chipsmall.com

Address: A1208, Overseas Decoration Building, #122 Zhenhua RD., Futian, Shenzhen, China



REVISIONS					
P	LTR	DESCRIPTION	DATE	DWN	APVD
A		RELEASED DRAWING	28JULY2016	TZ	SZ

NOTES, UNLESS OTHERWISE SPECIFIED:

1. "TE", PART NUMBER AND DATE CODE TO BE MARKED IN AREA SHOWN.
2. MATERIAL:
 HOUSING - GLASS FILLED HIGH TEMP THERMO PLASTIC.
 COLOR: BLACK, UL94 V-0.
 SIGNAL CONTACT - HIGH CONDUCTIVITY COPPER ALLOY.
 POWER CONTACT - HIGH CONDUCTIVITY COPPER ALLOY.
3. CONTACT PLATING:
 MATING AREA - NOBLE METAL OVERALL NICKEL
 TAIL SIDE AREA - MATTE TIN OVERALL NICKEL.
4. MECHANICAL CONNECTOR KEEP OUT ZONE.
5. DATUM AND BASIC DIMENSIONS ESTABLISHED BY CUSTOMER.
6. PCB - ALL HOLE DIAMETERS ARE FINISHED HOLE SIZES.
7. PCB HOLE:
 POWER - 1.15±0.025 MM DRILLED HOLES SIZE PLATING WITH 0.0076 MM MIN.
 Sn OVER 0.025-0.076 MM Cu PLATING TO ACHIEVE A 1.02 MM DIA. HOLE.
 SIGNAL - 0.835±0.025 MM DRILLED HOLES SIZE PLATING WITH 0.0076 MM MIN.
 Sn OVER 0.025-0.076 MM Cu PLATING TO ACHIEVE A 0.72 MM DIA. HOLE.

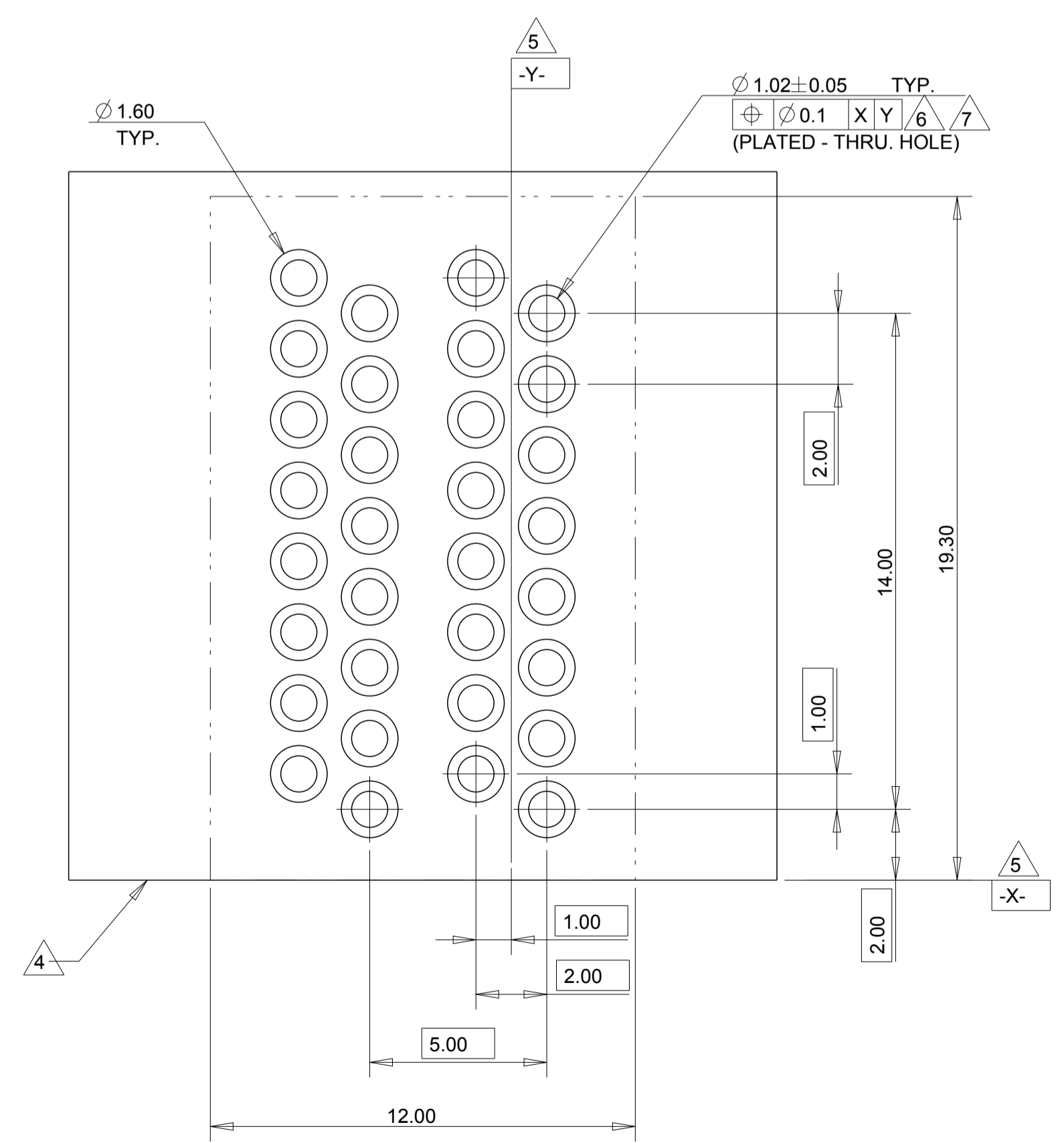
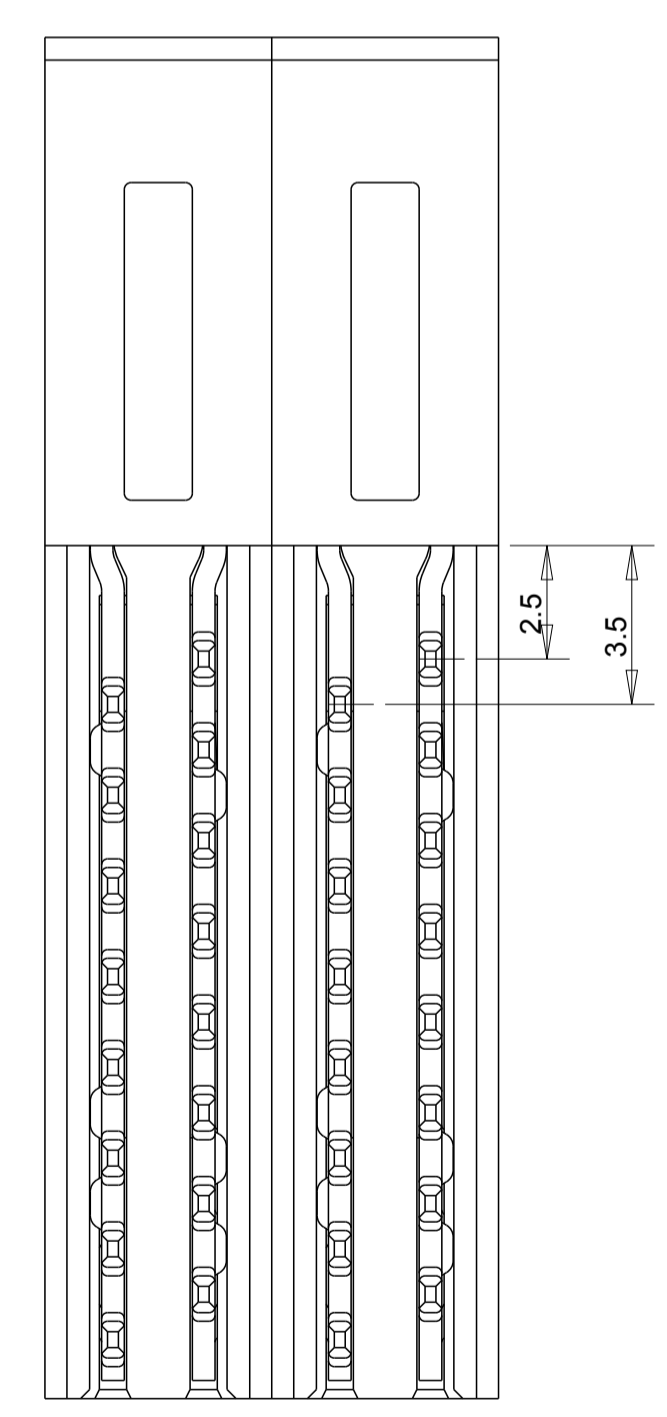
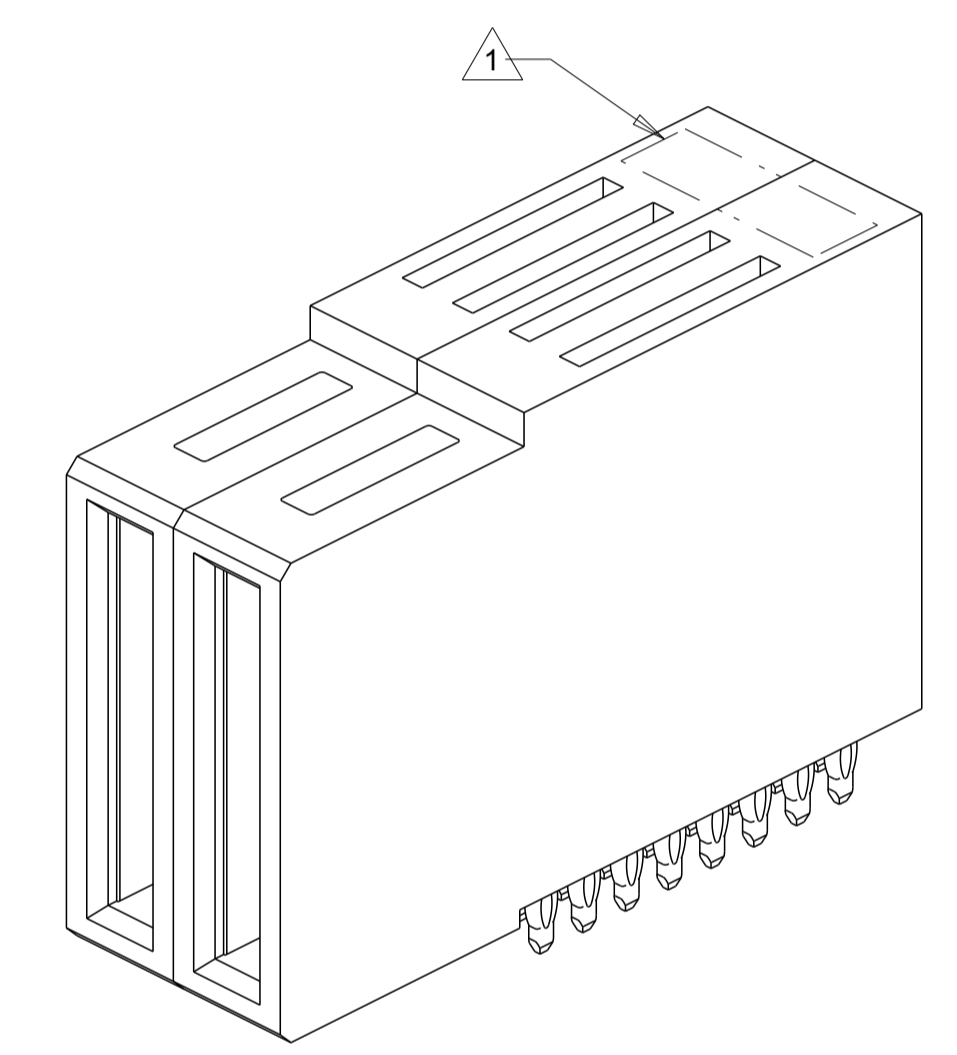
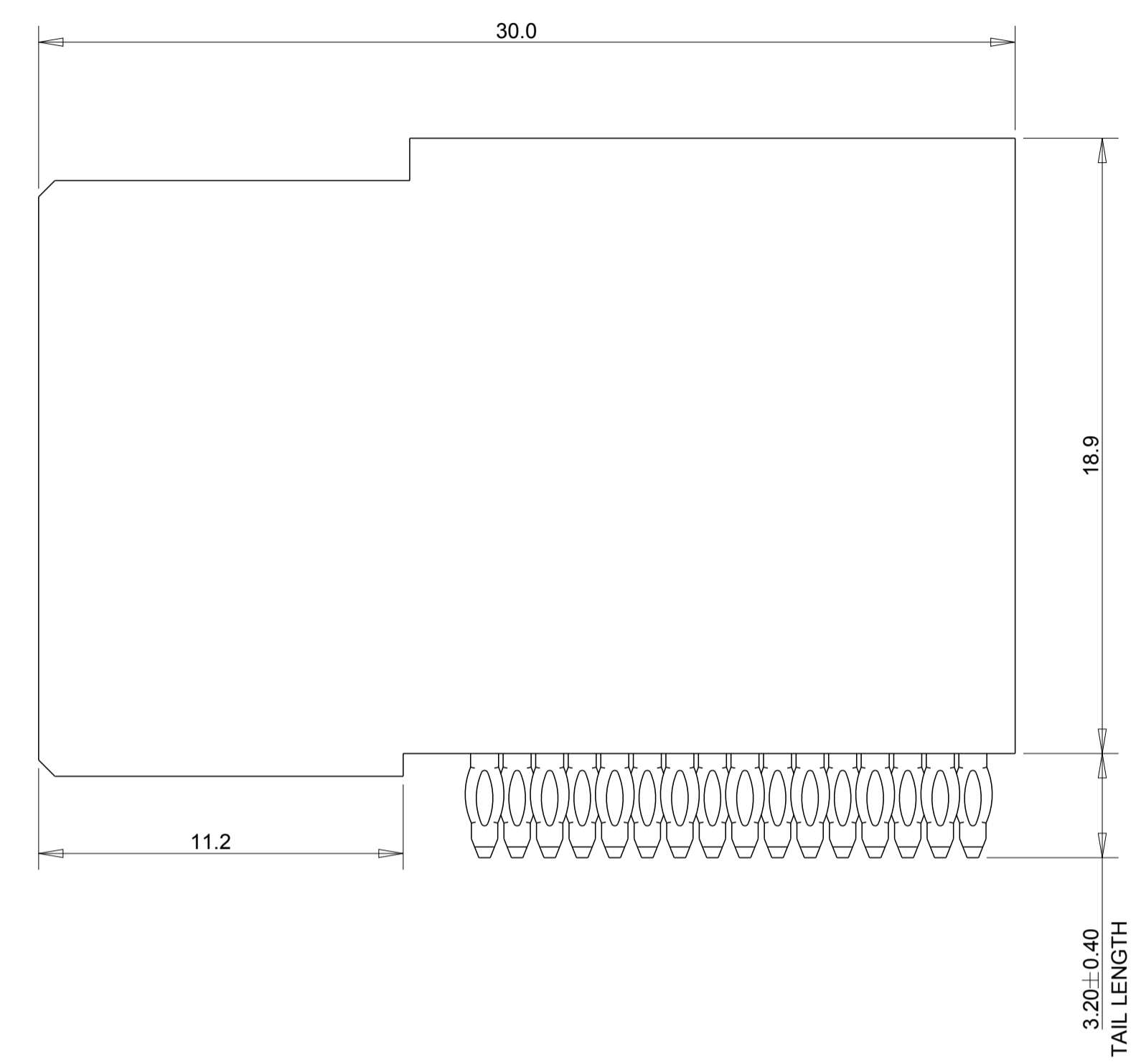
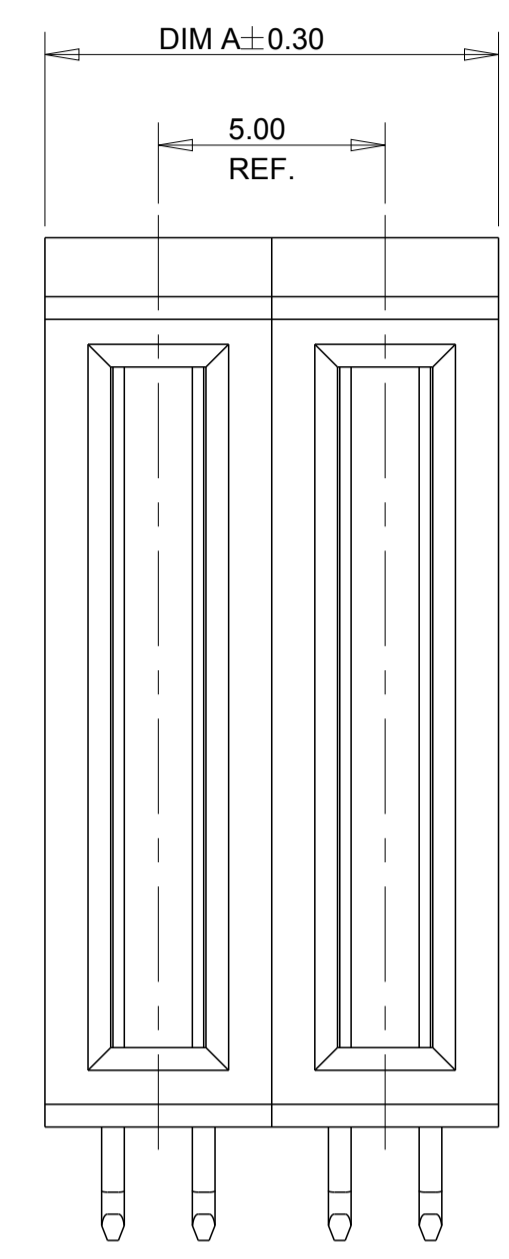

PART NUMBER	HOUSING	POWER	
		P 2	P 1
2204403-1	2204313-1	P R	P R
2P			

POWER CONTACT PRESS FIT	PR
DESCRIPTION	CODE

10.0	2P	2204403-1
DIM A	DESCRIPTION	PART NUMBER

THIS DRAWING IS A CONTROLLED DOCUMENT.

DWN: THOMAS ZHAO 16JUN2014	TE Connectivity Customer Drawing RIGHT ANGLE REC. PRESS FIT MULTI-BEAM HD W/GUIDELESS
CHK: SUNY ZHAO 16JUN2014	
APVD: SUNY ZHAO 16JUN2014	NAME: SUNY ZHAO
PRODUCT SPEC: -	APPLICATION SPEC: -
MATERIAL: -	WEIGHT: -
FINISH: -	RESTRICTED TO: -

SIZE: A1 CAGE CODE: - DRAWING NO: 2204403 SCALE: 1:1 SHEET 1 OF 1 REV A