



Chipsmall Limited consists of a professional team with an average of over 10 year of expertise in the distribution of electronic components. Based in Hongkong, we have already established firm and mutual-benefit business relationships with customers from,Europe,America and south Asia,supplying obsolete and hard-to-find components to meet their specific needs.

With the principle of “Quality Parts,Customers Priority,Honest Operation,and Considerate Service”,our business mainly focus on the distribution of electronic components. Line cards we deal with include Microchip,ALPS,ROHM,Xilinx,Pulse,ON,Everlight and Freescale. Main products comprise IC,Modules,Potentiometer,IC Socket,Relay,Connector.Our parts cover such applications as commercial,industrial, and automotives areas.

We are looking forward to setting up business relationship with you and hope to provide you with the best service and solution. Let us make a better world for our industry!



## Contact us

Tel: +86-755-8981 8866 Fax: +86-755-8427 6832

Email & Skype: info@chipsmall.com Web: www.chipsmall.com

Address: A1208, Overseas Decoration Building, #122 Zhenhua RD., Futian, Shenzhen, China



REVISIONS

P	LTR	DESCRIPTION	DATE	DWN	APVD
	A	REVISED AS PER ECR-15-009852	13JUL2015	RS	JL
	A1	REVISED AS PER ECR-15-012327	20AUG2015	RS	JL

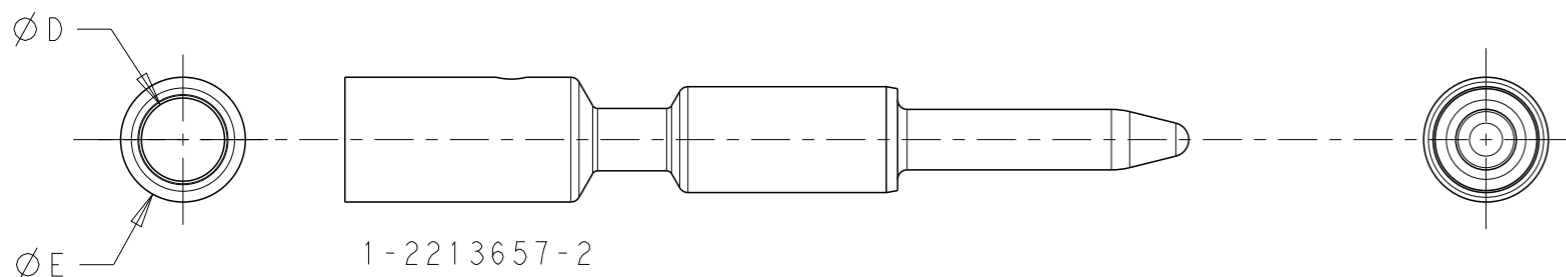
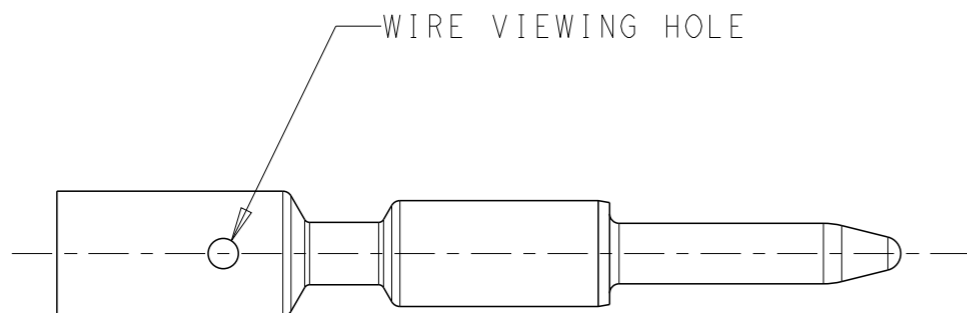

1-2213657-2

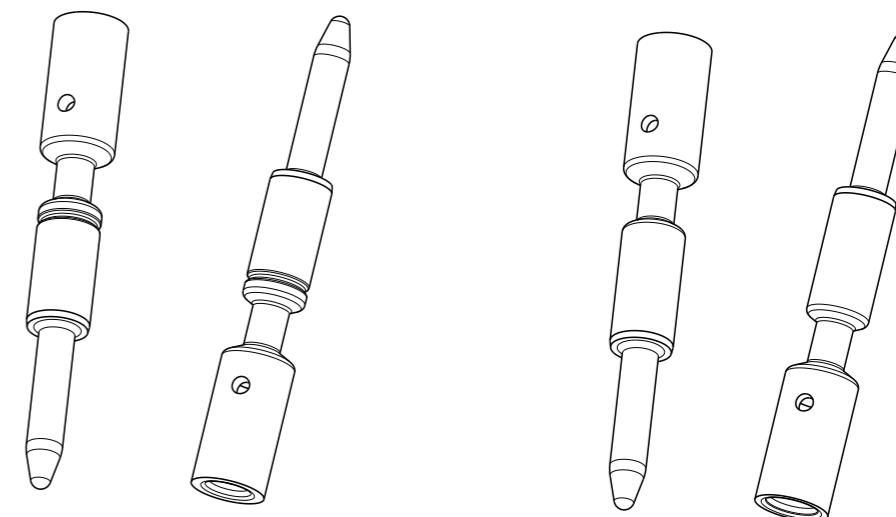

2213657-2

1-2213657-2

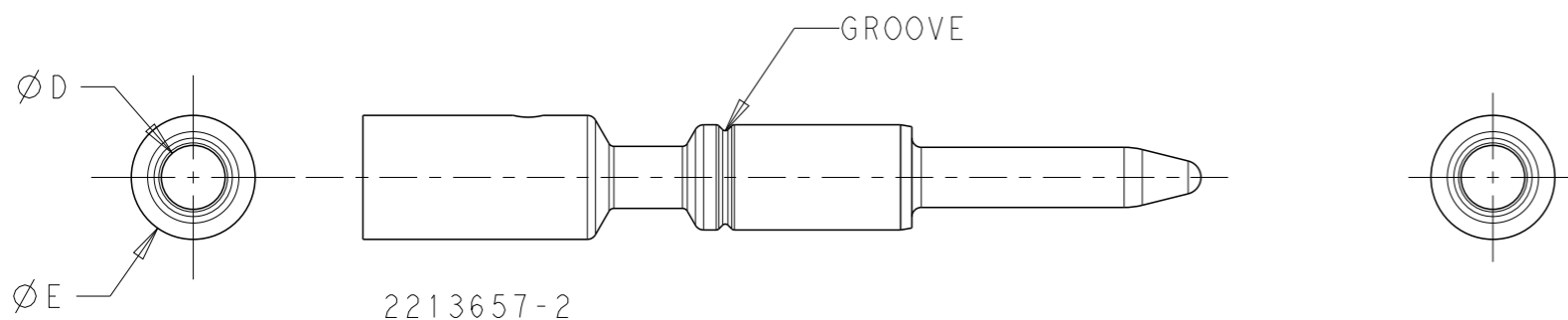

2213657-2

NOTES:

- MATERIALS AND FINISH:  
COPPER ALLOY, FINISH: Sn OVER Ni
- MUST COMPLY WITH DIRECTIVE 2002/95/EC (ROHS)
- THIS PRODUCT HAS NOT COMPLETED VALIDATION TESTING

2.5	3.30	2.20	0	1-2213657-2
1.5	3.30	1.70	1	2213657-2
WIRE (sqmm)	DIM. "E"	DIM. "D"	NO. OF GROOVES	PART NO

THIS DRAWING IS A CONTROLLED DOCUMENT.		DWN RAVI.S 17APR2015	 TE Connectivity		
DIMENSIONS: mm		CHK LATORRE JUSTIN 17APR2015			
TOLERANCES UNLESS OTHERWISE SPECIFIED:		APVD LATORRE JUSTIN 17APR2015	NAME MACHINED PIN CONTACT NECTOR* M-LINE-SEALED		
0 PLC ±- 1 PLC ±0.3 2 PLC ±0.15 3 PLC ±- 4 PLC ±- ANGLES ±-		PRODUCT SPEC 108-133014	SIZE A3		
MATERIAL NOTE 1		APPLICATION SPEC 114-32111	CAGE CODE -	DRAWING NO C-2213657	RESTRICTED TO -
FINISH NOTE 1		WEIGHT -	SCALE 10:1		
		Customer Drawing	SHEET 1 OF 1		
			REV A1		