



Chipsmall Limited consists of a professional team with an average of over 10 year of expertise in the distribution of electronic components. Based in Hongkong, we have already established firm and mutual-benefit business relationships with customers from,Europe,America and south Asia,supplying obsolete and hard-to-find components to meet their specific needs.

With the principle of “Quality Parts,Customers Priority,Honest Operation,and Considerate Service”,our business mainly focus on the distribution of electronic components. Line cards we deal with include Microchip,ALPS,ROHM,Xilinx,Pulse,ON,Everlight and Freescale. Main products comprise IC,Modules,Potentiometer,IC Socket,Relay,Connector.Our parts cover such applications as commercial,industrial, and automotives areas.

We are looking forward to setting up business relationship with you and hope to provide you with the best service and solution. Let us make a better world for our industry!



Contact us

Tel: +86-755-8981 8866 Fax: +86-755-8427 6832

Email & Skype: info@chipsmall.com Web: www.chipsmall.com

Address: A1208, Overseas Decoration Building, #122 Zhenhua RD., Futian, Shenzhen, China



LOC		DIST		REVISONS			
GP	00	P	LTN	DESCRIPTION	DATE	DWN	APVD
		A		INITIAL RELEASE	20APR2014	CW	SH
		B		ADD-3	25OCT2016	PP	SH

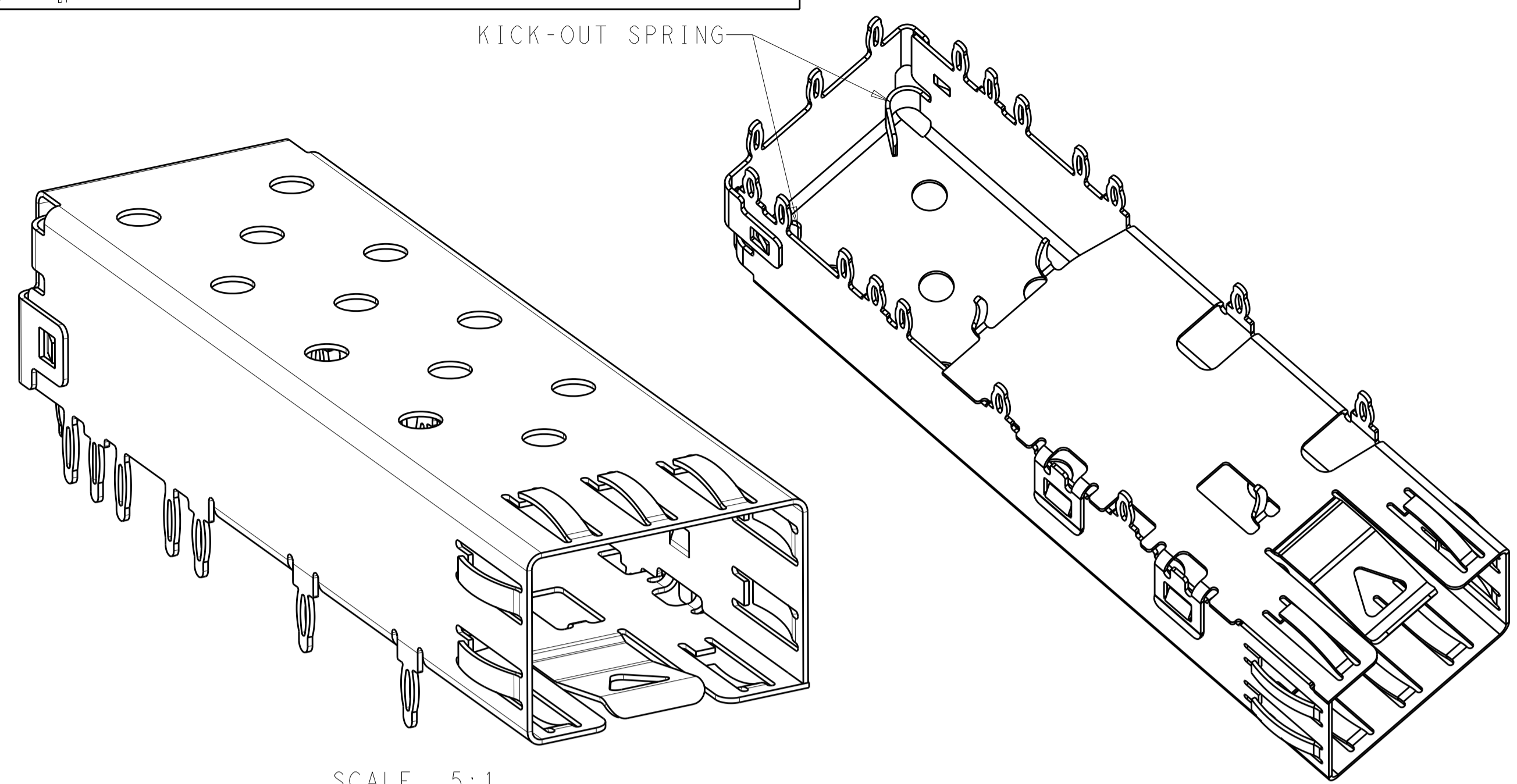

SCALE 5:1

SCALE 4:1

- 1 MATERIAL: 0.25mm THICK STAINLESS STEEL.
- 2 FINISH: NICKEL, NON PLATED EDGES PERMISSIBLE.
- 3. MATES WITH SFP MSA COMPLIANT TRANSCEIVERS.
- 4 PADS AND VIAS CHASSIS GROUND.
- 5 DATUM AND BASIC DIMENSION ESTABLISHED BY CUSTOMER.
- 6. MINIMUM PC BOARD THICKNESS:
SINGLE SIDED = 1.50 mm
- 7 REFERENCE APPLICATION SPEC. 114-13120, HOLE A, FOR
RECOMMENDED DRILL HOLE DIAMETER AND PLATING THICKNESS(EXCEPT IMMERSION SILVER PLATING).
- 8 REFERENCE APPLICATION SPEC. 114-13120, HOLE C, FOR
RECOMMENDED DRILL HOLE DIAMETER AND PLATING THICKNESS(EXCEPT IMMERSION SILVER PLATING).
- 9. THE RECOMMENDED DIMENSIONS FOR HOLES ON PAGE 2/2 ARE NOT COMPATIBLE WITH IMMERSION SILVER PLATING HOLES
BECAUSE OF OVERLARGE INSERTION FORCE.

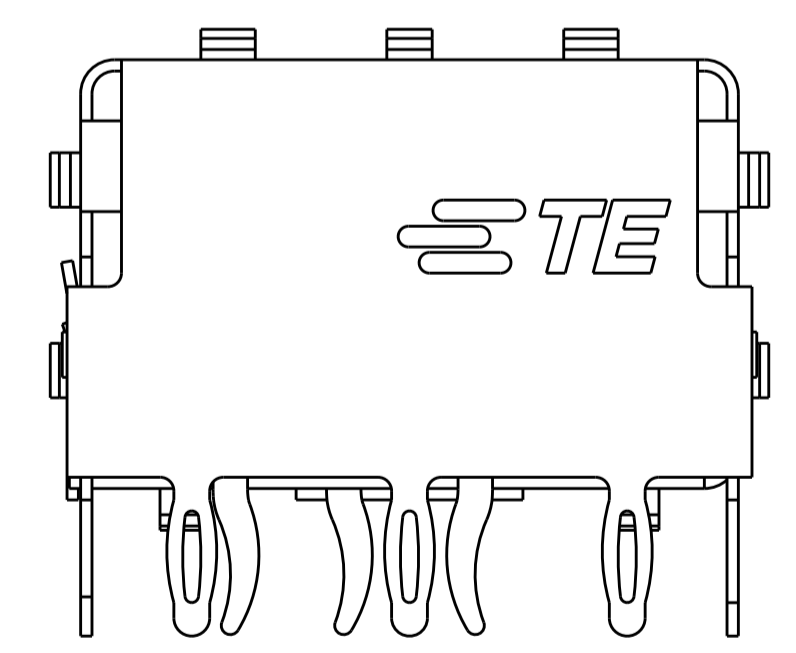
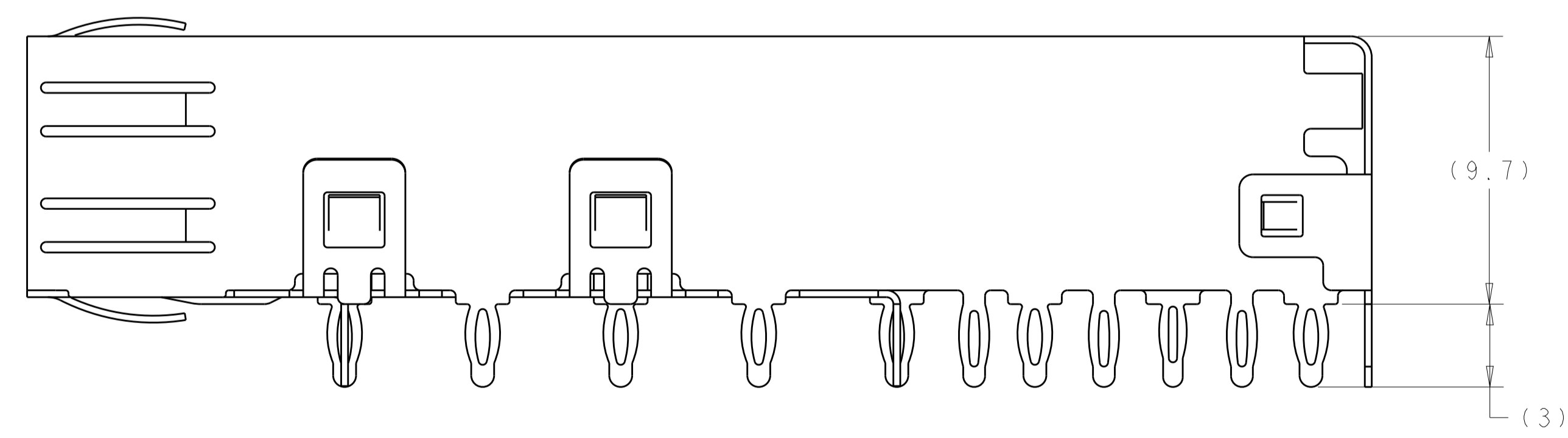
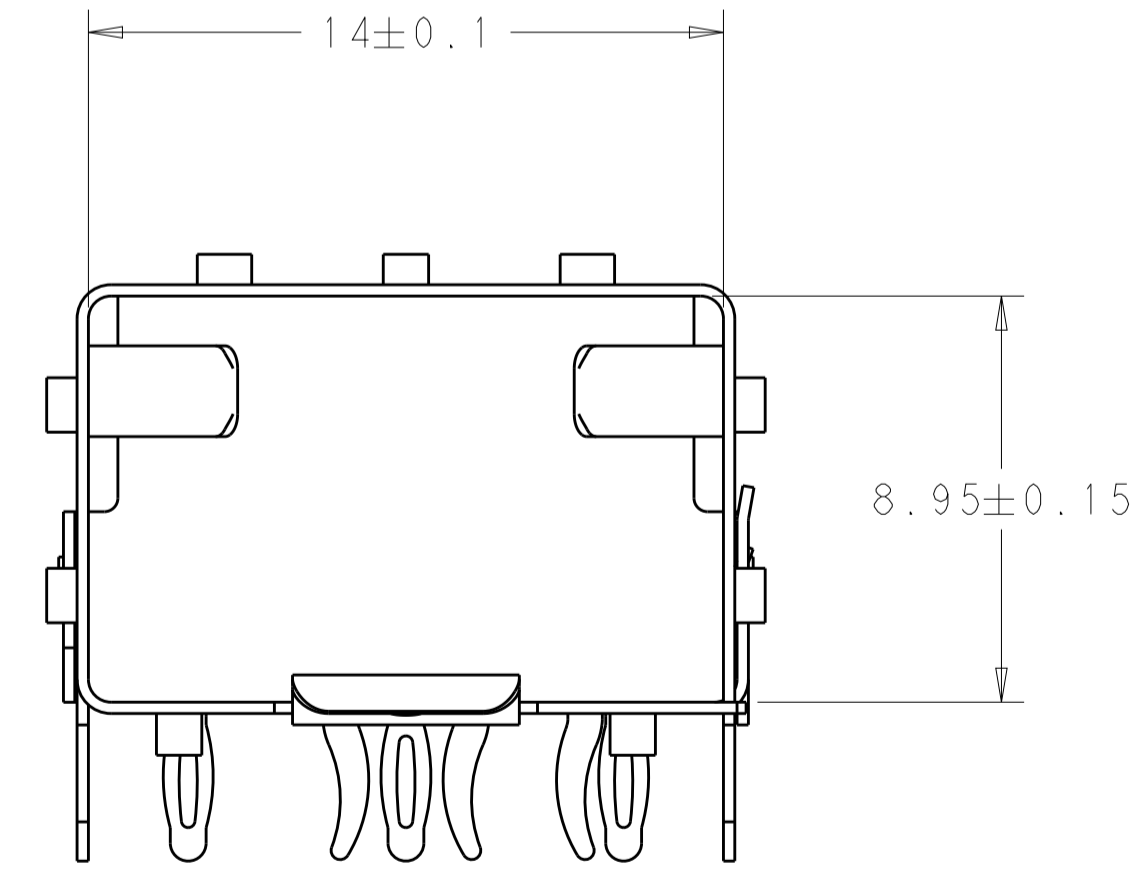
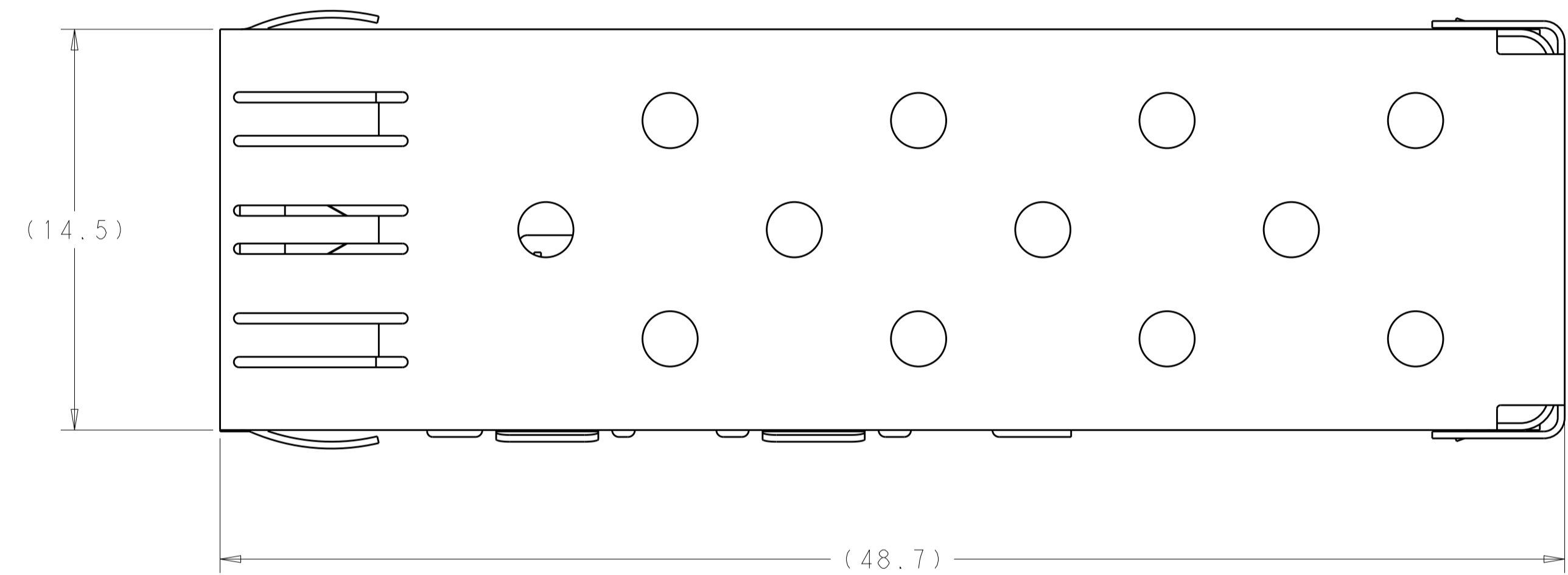

WITHOUT KICK-OUT SPRING(PAGE 2)	2227023-3
WITH KICK-OUT SPRING(PAGE 1)	2227023-1
DESCRIPTION	PART NUMBER

THIS DRAWING IS A CONTROLLED DOCUMENT. DIMENSIONING AND TOLERANCING PER ASME Y14.5M-2009		DWN C. VALENTINE 07NOV2012	APVD M. SCHMITT 07NOV2012	NAME SFP, 1X1 SINGLE PIECE CAGE, PRESS FIT
DIMENSIONS: mm	TOLERANCES UNLESS OTHERWISE SPECIFIED: 0 PLC ± 1 PLC ±0.2 2 PLC ±0.1 3 PLC ±0.1 4 PLC ± ANGLES ±	CHK M. SCHMITT 07NOV2012	PRODUCT SPEC 108-1950	RESTRICTED TO
MATERIAL	FINISH	APPLICATION SPEC 114-13120	SIZE A100779	SCALE 6:1 SHEET 1 OF 3 REV B
CUSTOMER DRAWING		WEIGHT	C=2227023	

LOC		DIST		REVISIONS			
P.	LTN	DESCRIPTION	DATE	DWN	APVD		
-	-	SEE SHEET 1	-	-	-		

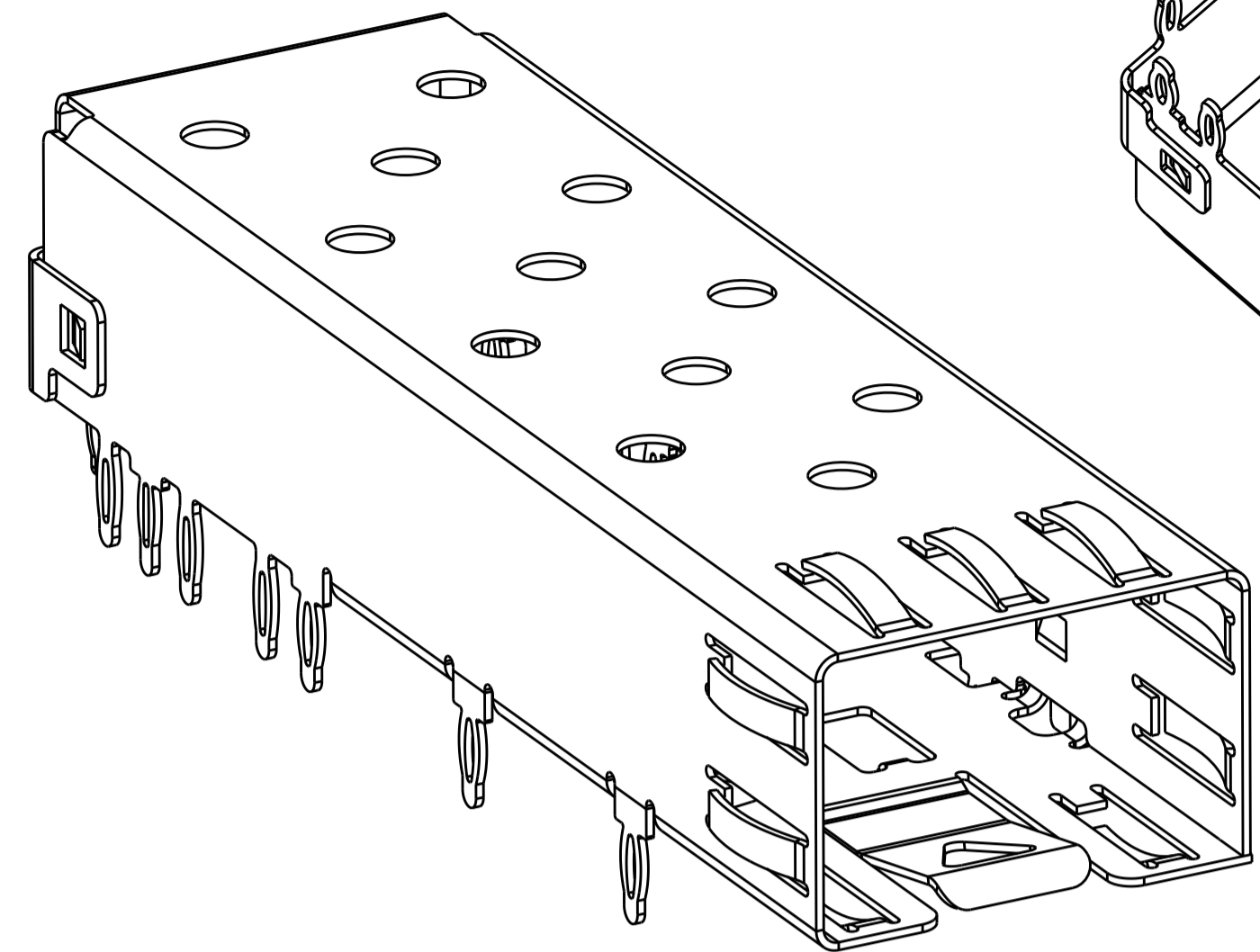

SCALE 5:1

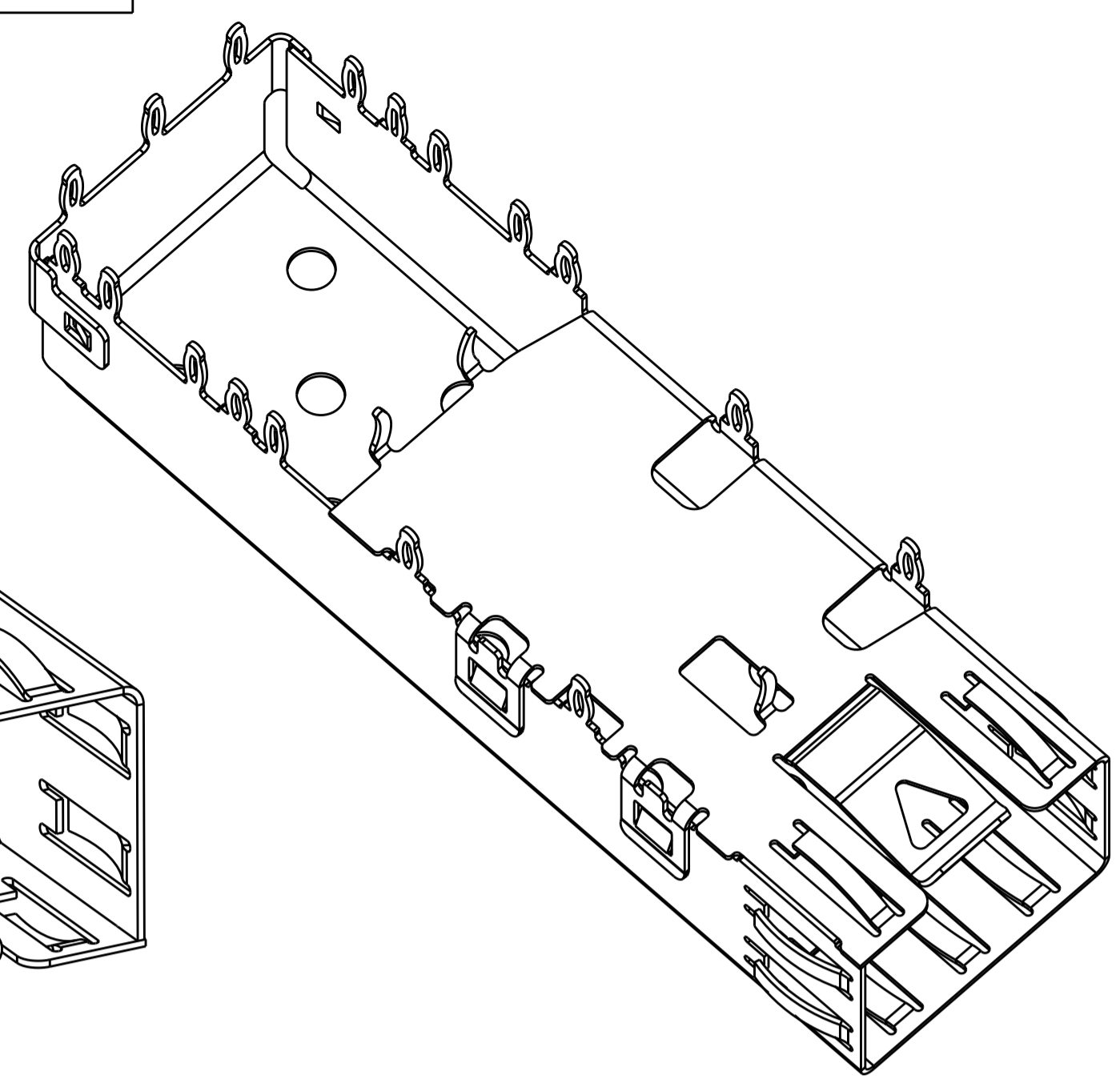

SCALE 4:1

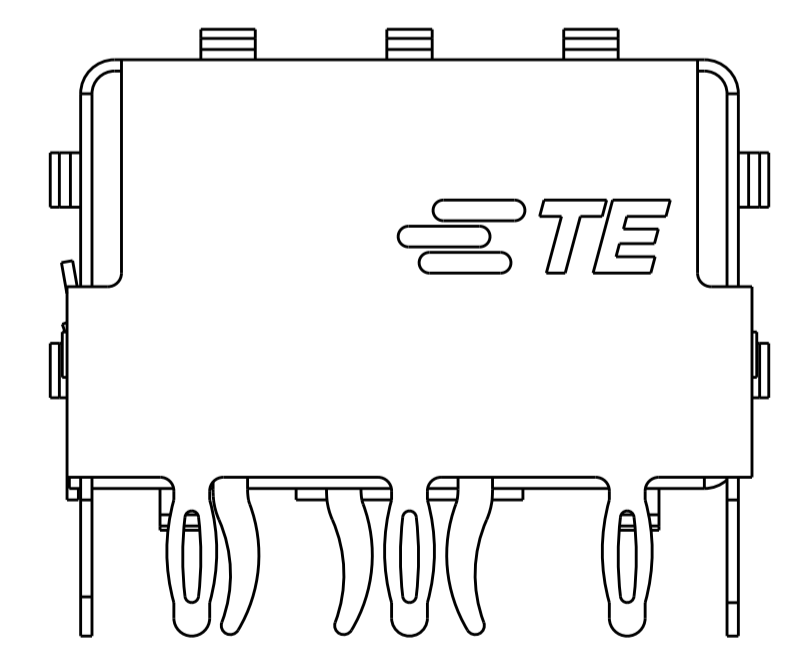
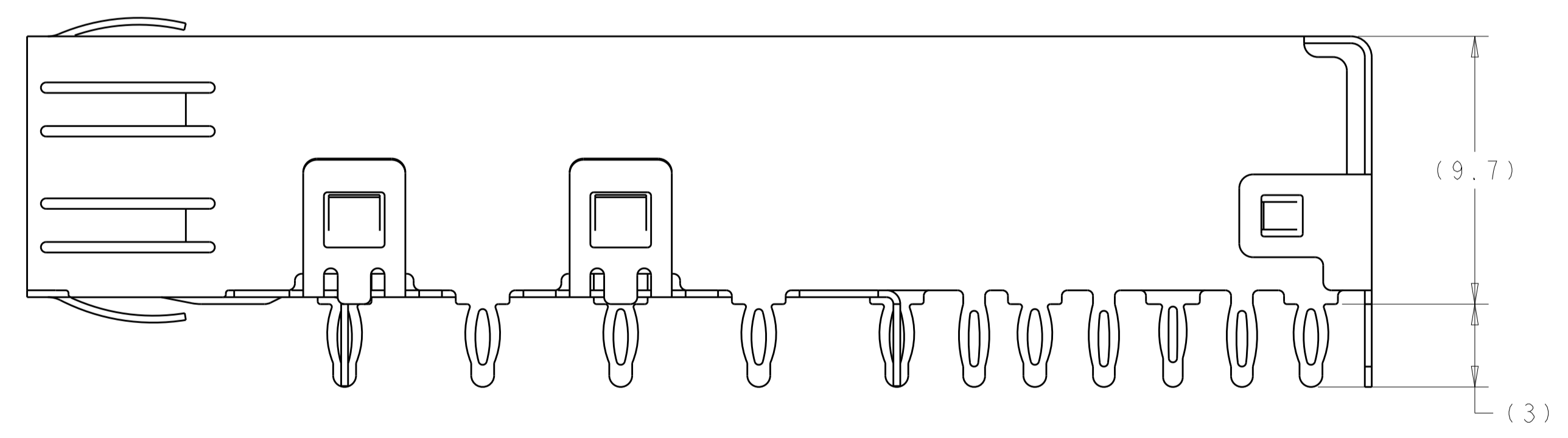
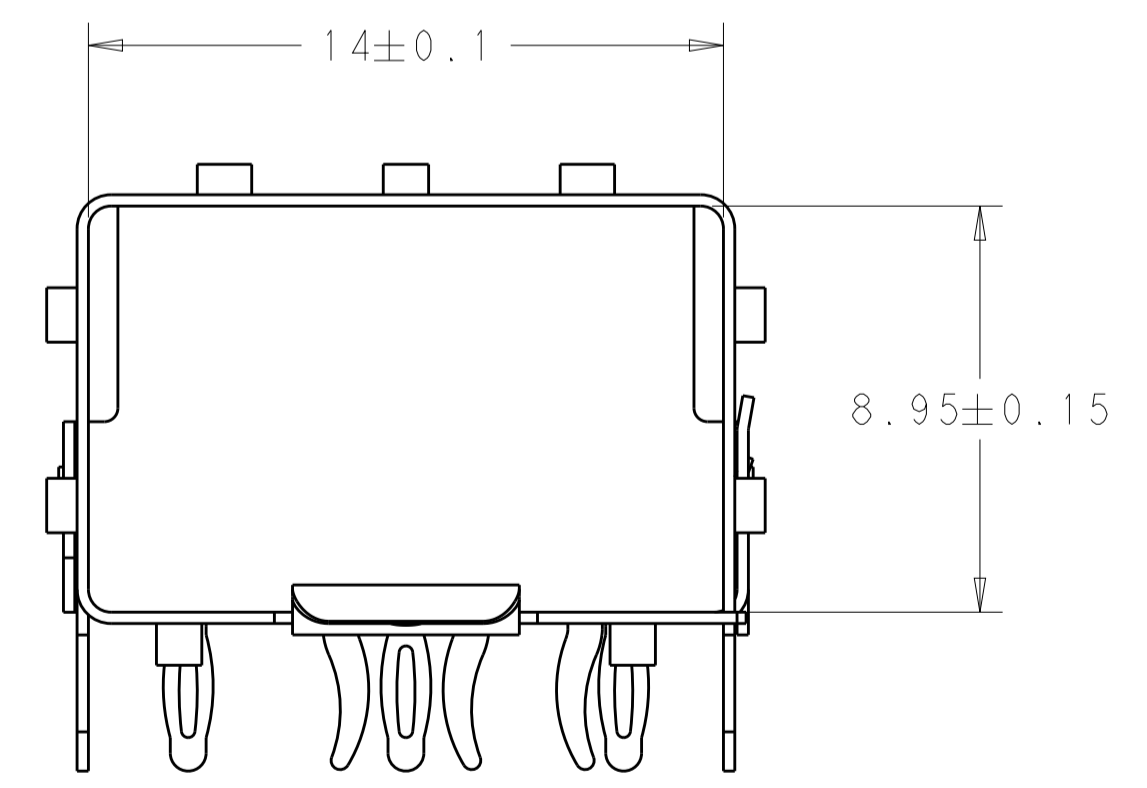
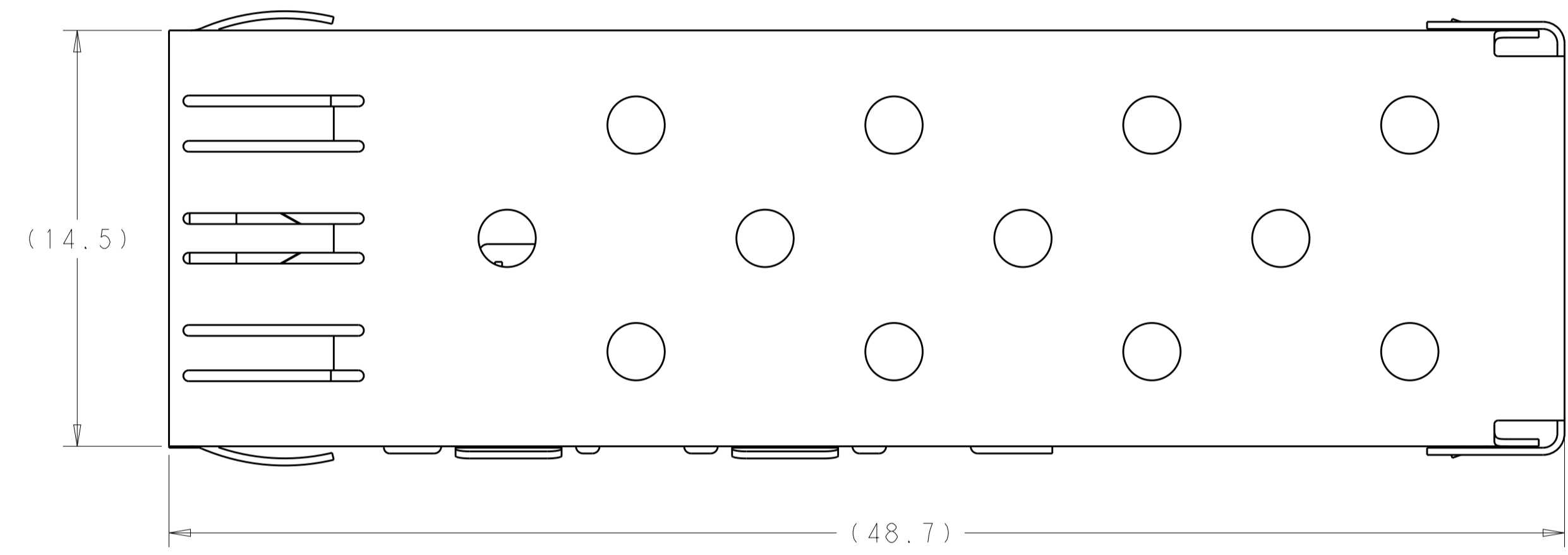

THIS DRAWING IS A CONTROLLED DOCUMENT.		DWN C. VALENTIN 07NOV2012	TE Connectivity
DIMENSIONS:		CHK M. SCHMITT 07NOV2012	
mm	TOLERANCES UNLESS OTHERWISE SPECIFIED:	APVD M. SCHMITT 07NOV2012	NAME SFP, 1X1 SINGLE PIECE CAGE, PRESS FIT
0 PLC	±	PRODUCT SPEC	108-1950
1 PLC	±0.2	APPLICATION SPEC	114-13120
2 PLC	±0.1	SIZE	A100779
3 PLC	±0.1	WEIGHT	C=2227023
4 PLC	±	Customer Drawing	SCALE 6:1 SHEET 2 OF 3 REV B
ANGLES	±		
FINISH			

LOC	DIST	REV	DATE	DWN	APVD
GP	00				

REVISIONS		
REV	DESCRIPTION	DATE
-	SEE SHEET 1	-

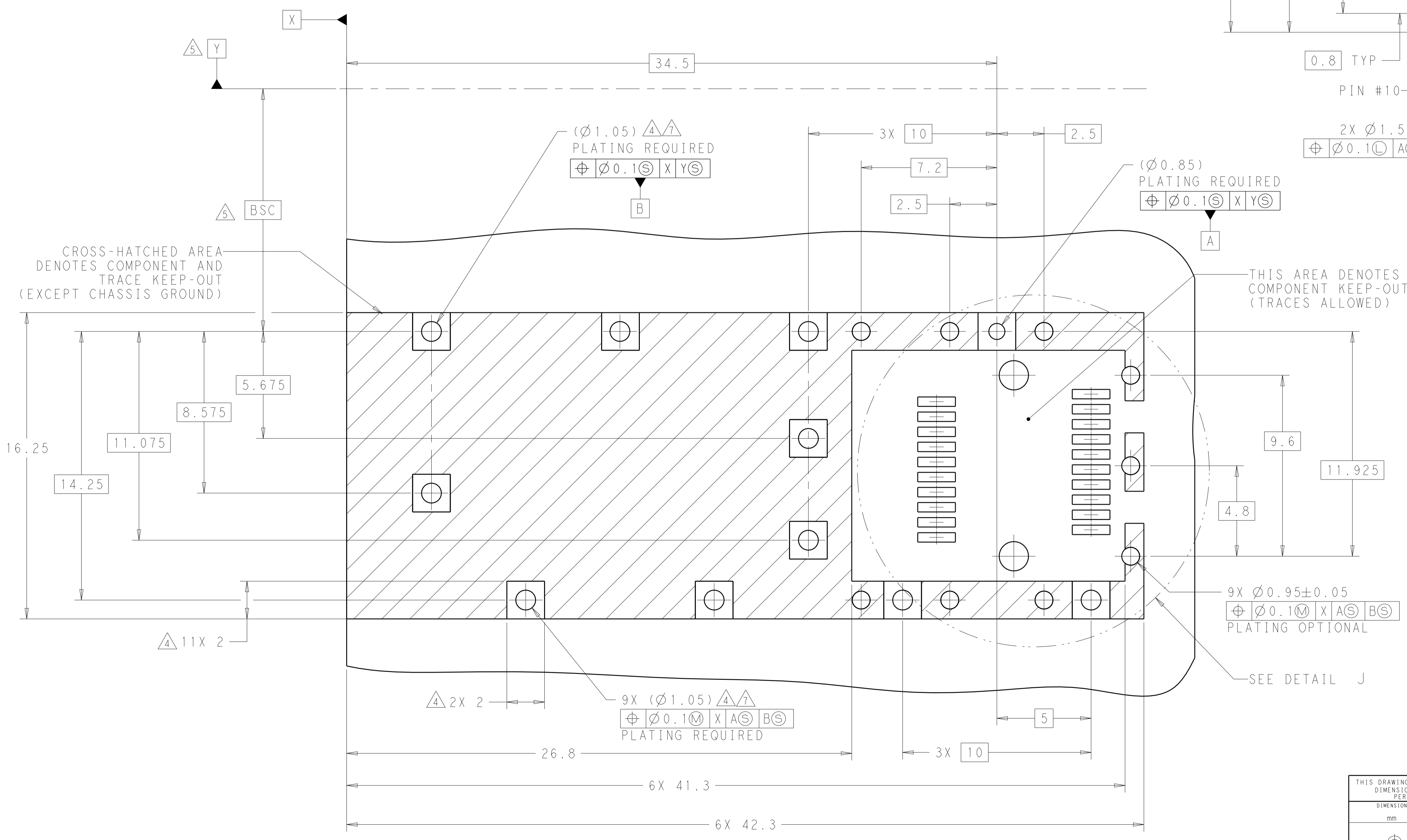
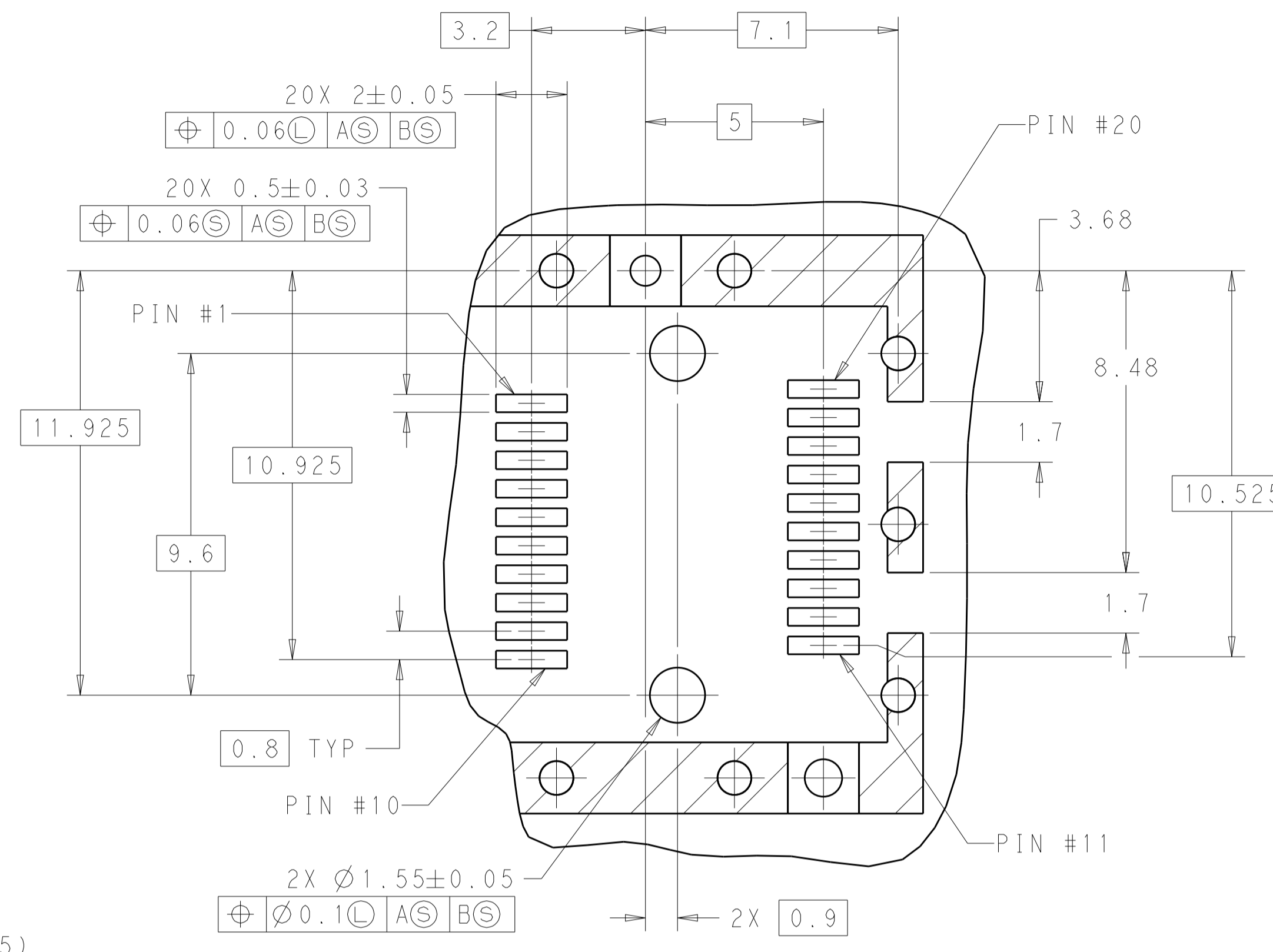
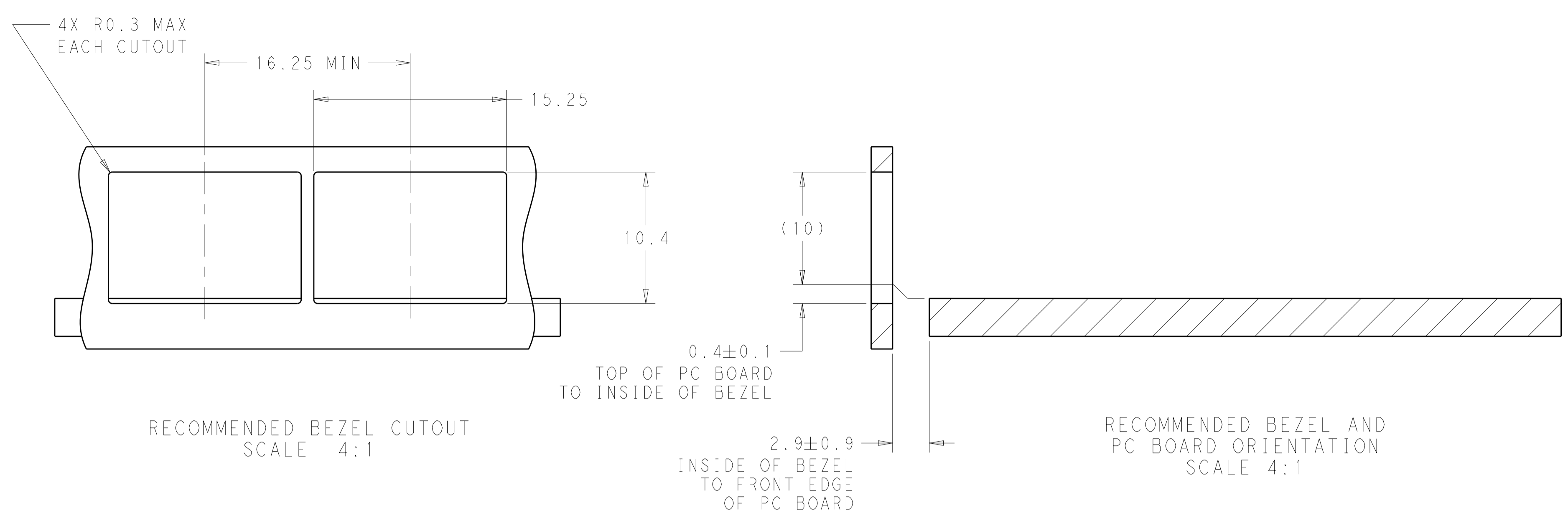

THIS DRAWING IS A CONTROLLED DOCUMENT. DIMENSIONING AND TOLERANCING PER ASME Y14.5M-2009		DWN: C. VALENTINE 07NOV2012 CHK: M. SCHMITT 07NOV2012 APVD: M. SCHMITT 07NOV2012	NAME: SFP, 1X1 SINGLE PIECE CAGE, PRESS FIT
DIMENSIONS: mm	TOLERANCES UNLESS OTHERWISE SPECIFIED:	PRODUCT SPEC: 108-1950	SIZE: A1
0 PLC ±0.2	1 PLC ±0.1	APPLICATION SPEC: 114-13120	RESTRICTED TO: -
2 PLC ±0.1	3 PLC ±0.1	WEIGHT: -	SCALE: 1:1
4 PLC ±0.1	ANGLES ±0.1	CUSTOMER DRAWING	SHEET 3 OF 3
MATERIAL: -	FINISH: -	SCALE: 1:1	REV: B