



Chipsmall Limited consists of a professional team with an average of over 10 year of expertise in the distribution of electronic components. Based in Hongkong, we have already established firm and mutual-benefit business relationships with customers from,Europe,America and south Asia,supplying obsolete and hard-to-find components to meet their specific needs.

With the principle of "Quality Parts,Customers Priority,Honest Operation,and Considerate Service",our business mainly focus on the distribution of electronic components. Line cards we deal with include Microchip,ALPS,ROHM,Xilinx,Pulse,ON,Everlight and Freescale. Main products comprise IC,Modules,Potentiometer,IC Socket,Relay,Connector.Our parts cover such applications as commercial,industrial, and automotives areas.

We are looking forward to setting up business relationship with you and hope to provide you with the best service and solution. Let us make a better world for our industry!



Contact us

Tel: +86-755-8981 8866 Fax: +86-755-8427 6832

Email & Skype: info@chipsmall.com Web: www.chipsmall.com

Address: A1208, Overseas Decoration Building, #122 Zhenhua RD., Futian, Shenzhen, China



LOC	DIST	REVISIONS			
P	LTN	DESCRIPTION	DATE	DWN	APVD
A		RELEASED FOR PRODUCTION	03MAR2016	TX	SH
A1		ADDED NEW DASH NUMBER 2227670 -7	15JUL2016	TX	SH
B		REVISED PER ECO-16-014569	18OCT2016	TX	SH

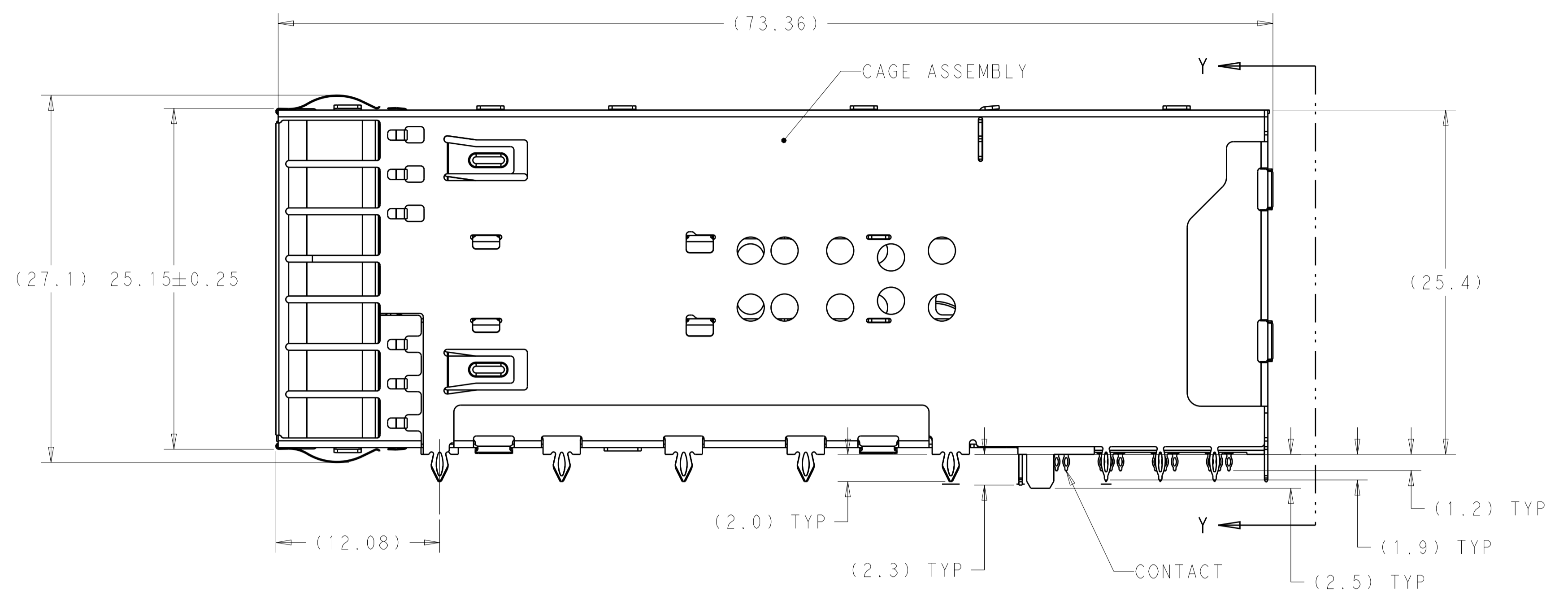
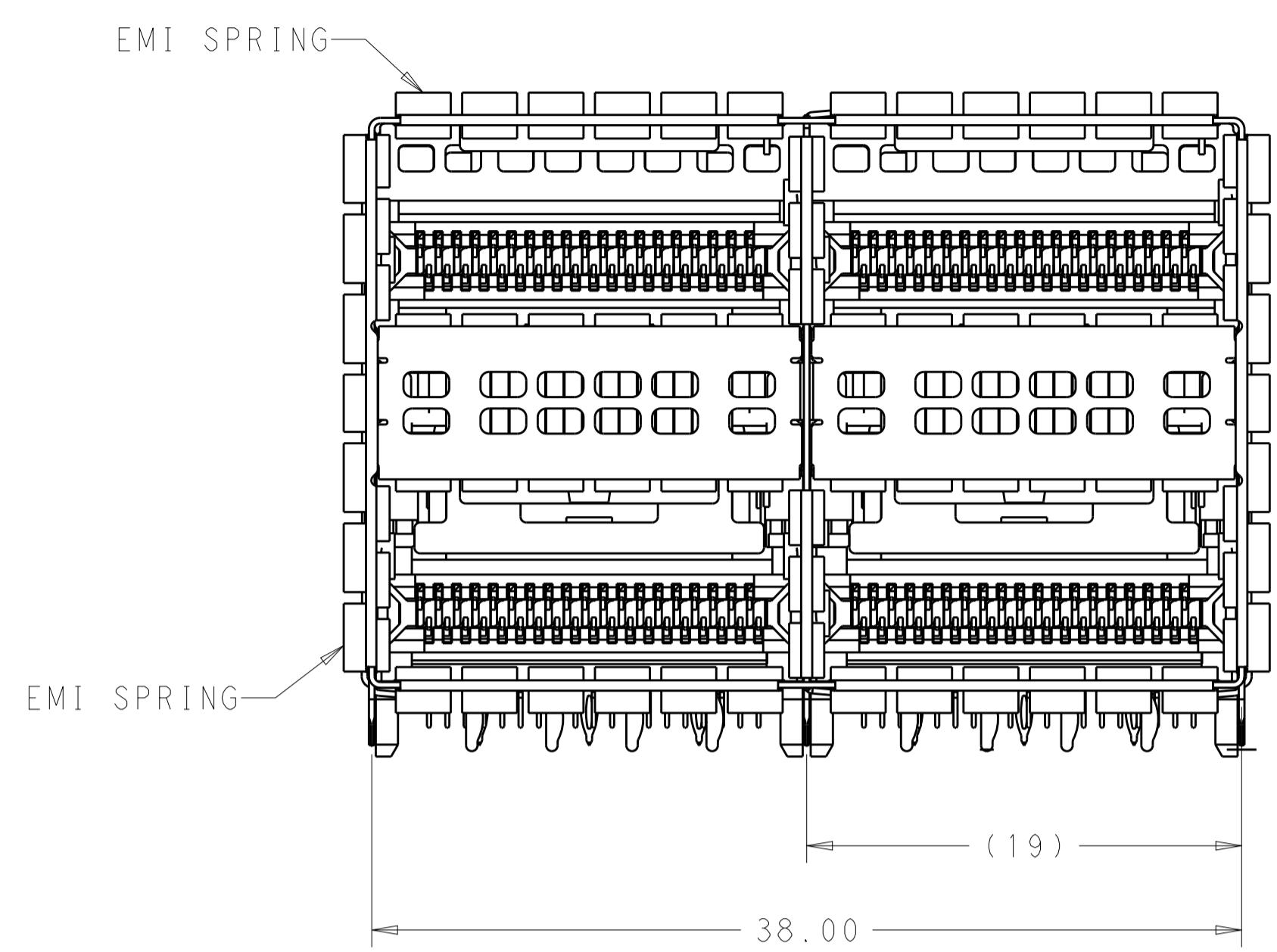

2227670-1/4 AS SHOWN

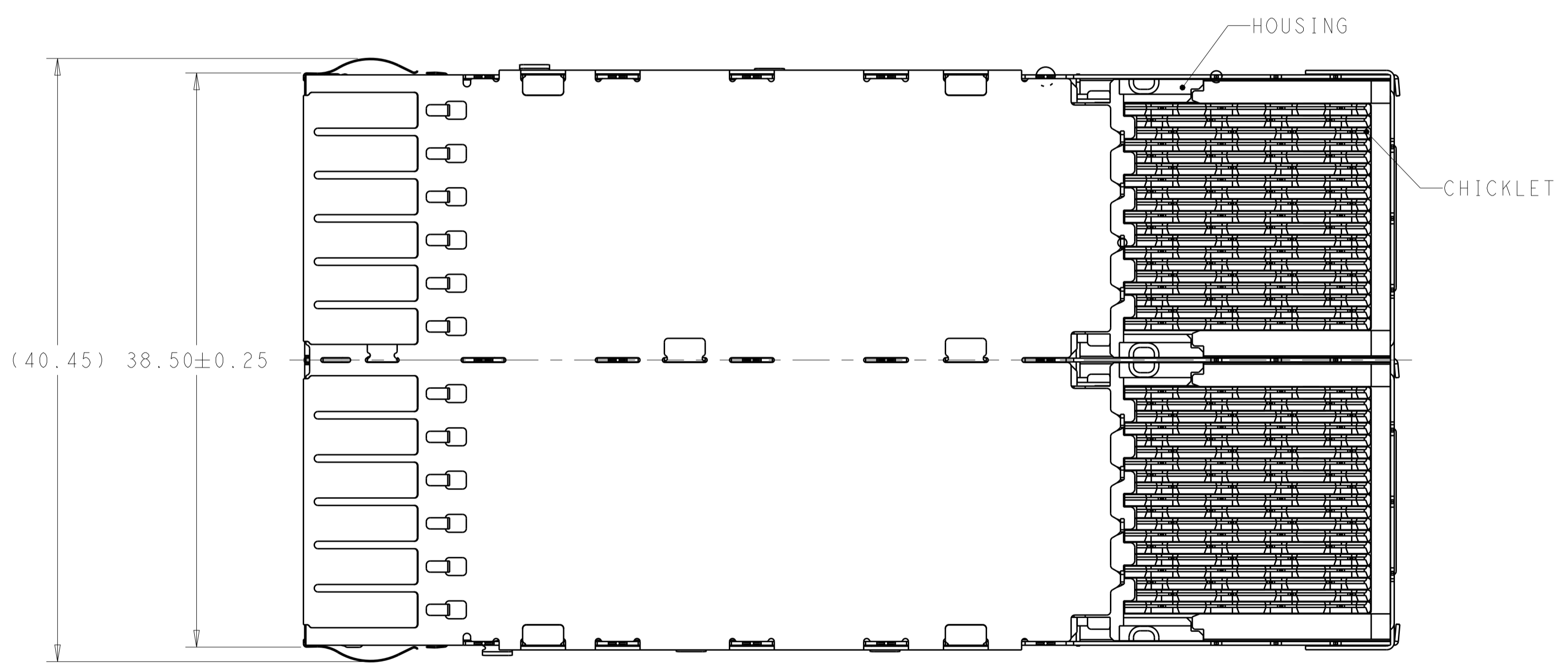

1. MATERIALS:
 CAGE ASSEMBLY- NICKEL SILVER ALLOY PER ASTM B 122.
 EMI SPRING- COPPER ALLOY, NICKEL PLATED.
 HOUSING- POLYESTER LCP WITH 94V-0.
 CHICKLET- POLYESTER LCP WITH 94V-0.
 CONTACT- COPPER ALLOY.
 LIGHTPIPE- POLYCARBONATE WITH 94V-0.
2. CONTACT FINISH: 0.76µm GOLD ON MATING END, 1.25µm MATT TIN ON SOLDER TAIL, ALL OVER 1.27µm NICKEL.
3. DATUM AND BASIC DIMENSION ESTABLISHED BY CUSTOMER.
4. MINIMUM PCB THICKNESS OF 1.57.
5. THE ENTIRE AREA OF THE CONNECTOR FOOTPRINT, INDICATED BY THE DASHED LINE, TO BE CONSIDERED THE KEEPOUT AREA FOR COMPONENTS AND TRACES.
6. CROSS-HATCHED AREAS REPRESENT ZONES ON THE PCB THAT COME IN CONTACT WITH OR BE IN CLOSE PROXIMITY TO THE PLASTIC HOUSING OR THE CONNECTOR CAGE. INDICATED AREAS TO BE CONSIDERED TRACE FREE.
7. PART NUMBER AND DATE CODE MAKED IN APPROXIMATE AREA SHOWN.
8. HATCHED AREA IS PLACEMENT ZONE FOR LED. LED SHOULD BE CENTERED WITHIN ZONE. RECOMMEND 0805 PACKAGE.
9. CONTACT FINISH: 0.08µm MINIMUM GOLD OVER 0.68µm PALLADIUM-NICKEL ON MATING END, 1.25µm MATT TIN ON SOLDER TAIL, ALL OVER 1.27µm NICKEL.

CONTACT FINISH	DESCRIPTION	PART NUMBER
2	NO LIGHTPIPE	2227670-7
9	LEFT INDICATOR DOWN	2227670-6
9	LEFT INDICATOR UP	2227670-5
9	NO LIGHTPIPE	2227670-4
2	LEFT INDICATOR DOWN	2227670-3
2	LEFT INDICATOR UP	2227670-2
2	NO LIGHTPIPE	2227670-1

THIS DRAWING IS A CONTROLLED DOCUMENT.

DIMENSIONS:	TOLERANCES UNLESS OTHERWISE SPECIFIED:	DWN M. SHIRK 18JAN2013	TE Connectivity
mm	0 PLC ±0.25 1 PLC ±0.15 3 PLC ±0.15 4 PLC ±0.15	CHK D. SZCZESNY 18JAN2013	
MATERIAL	FINISH	APVD	NAME
SEE NOTE 1	SEE NOTE 2	PRODUCT SPEC 108-60102	CAGE AND CONNECTOR ASSEMBLY, WITH EMI SPRING, THRU BEZEL, 2X2, ZQSFP+ STACKED
		APPLICATION SPEC 114-60015	SIZE CAGE CODE DRAWING NO RESTRICTED TO
		WEIGHT	A100779C=2227670
		CUSTOMER DRAWING	SCALE 4:1 SHEET 1 OF 4 REV B

LOC		DIST		REVISIONS			
P	LTN	DESCRIPTION	DATE	DMN	APVD		
-	-	SEE SHEET 1	-	-	-		

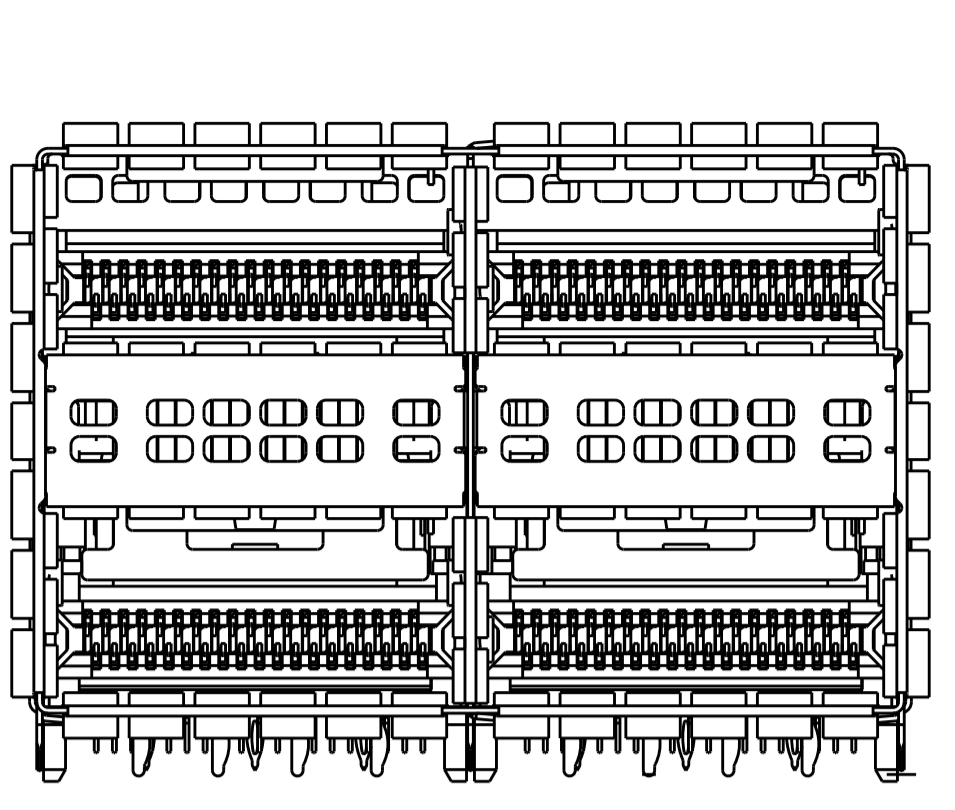

2227670-1, 2227670-4
 2227670-7
 NO LIGHTPIPE IN ASSEMBLY
 SCALE 3:1

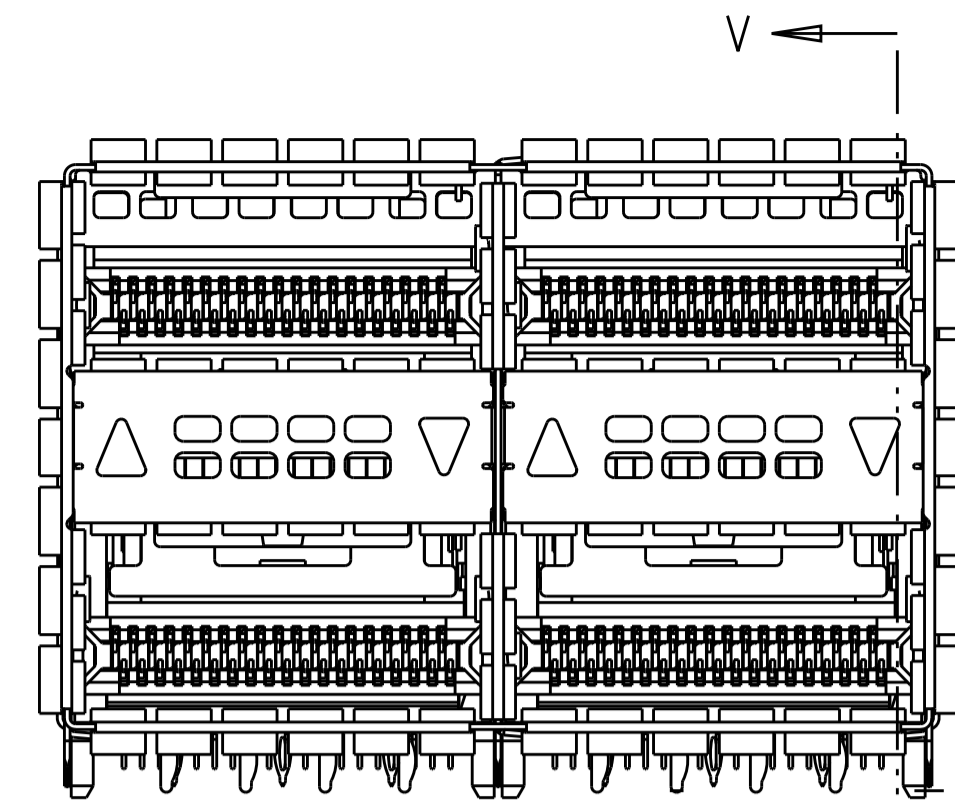

2227670-2 / 2227670-5
 LEFT LIGHTPIPE INDICATOR
 POINTING TO UPPER PORT
 SCALE 3:1

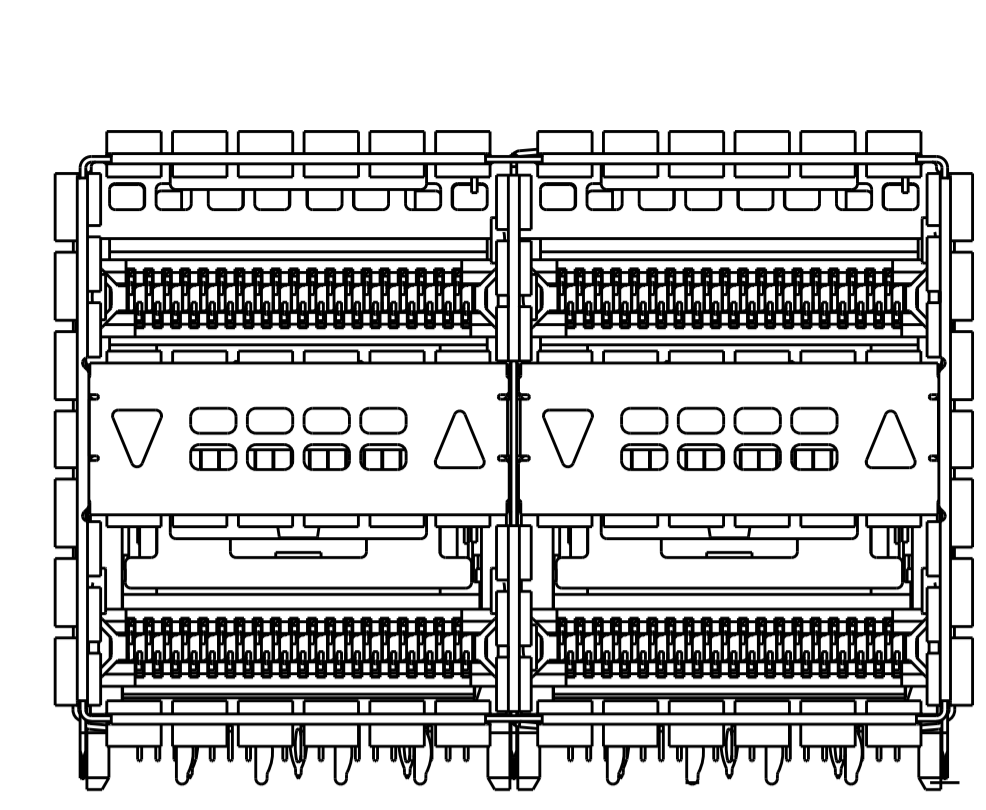

2227670-3 / 2227670-6
 LEFT LIGHTPIPE INDICATOR
 POINTING TO LOWER PORT
 SCALE 3:1

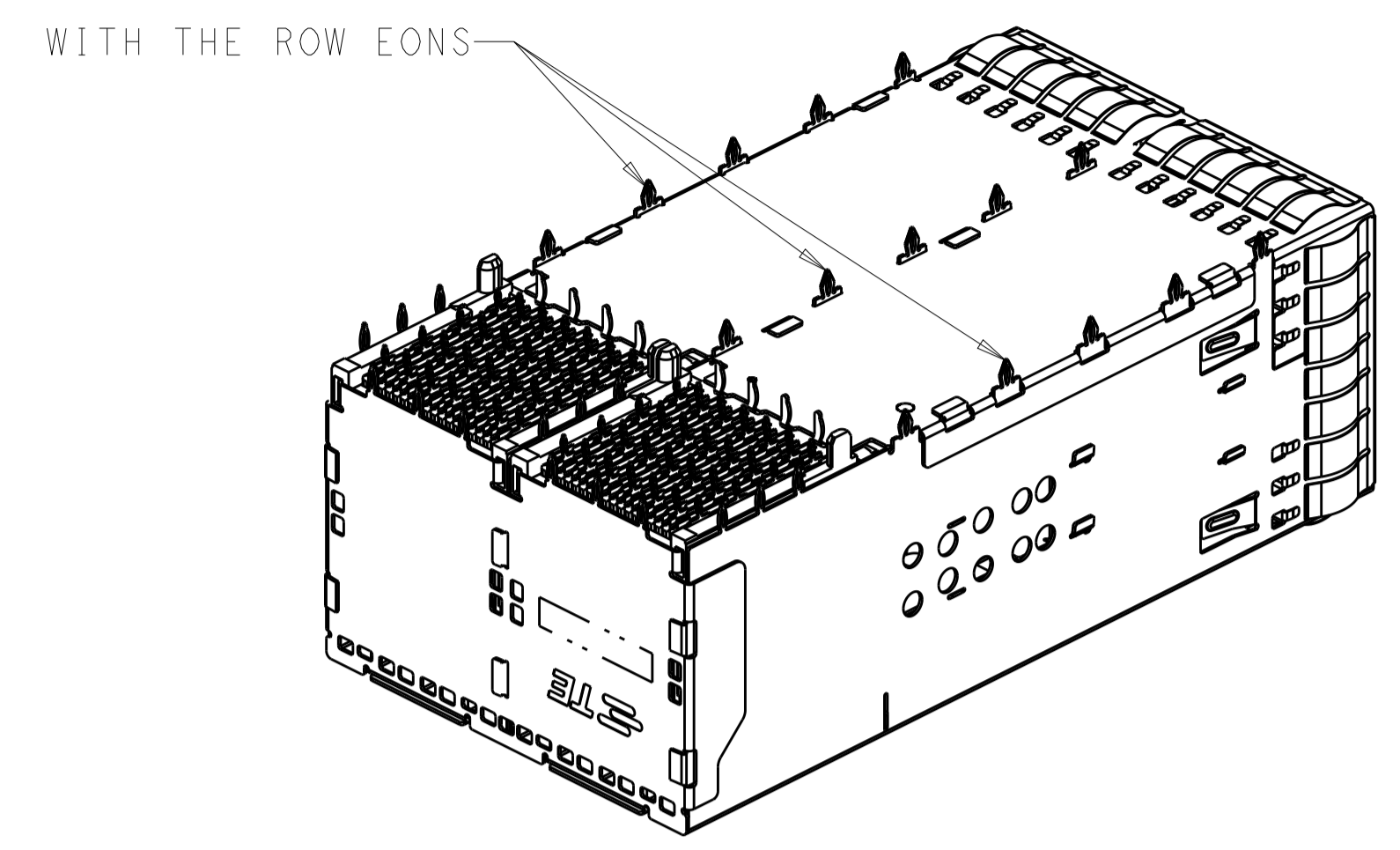

2227670-1 TO 2227670-6 AS SHOWN
 SCALE 2:1

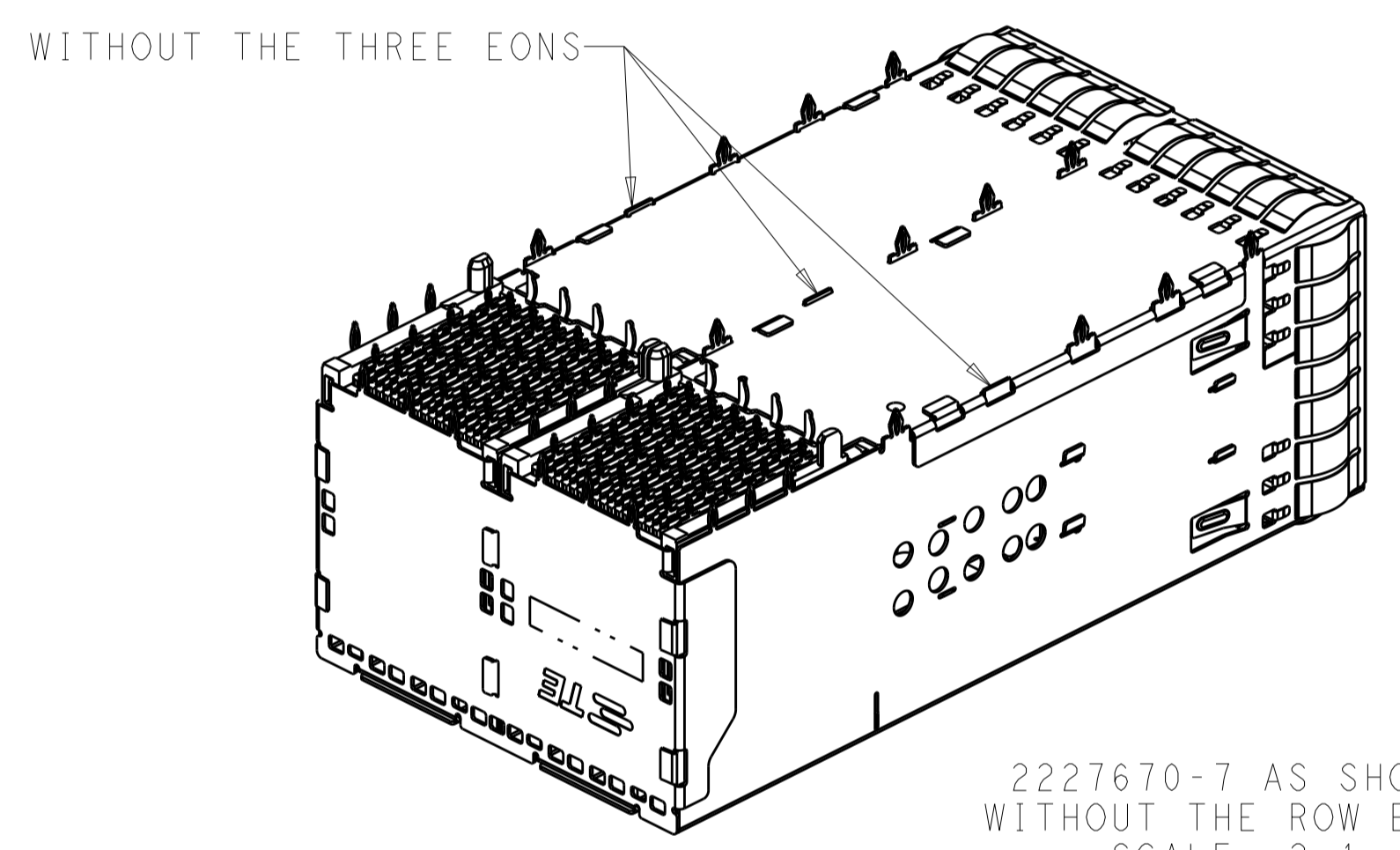

2227670-7 AS SHOWN
 WITHOUT THE ROW EONS
 SCALE 2:1

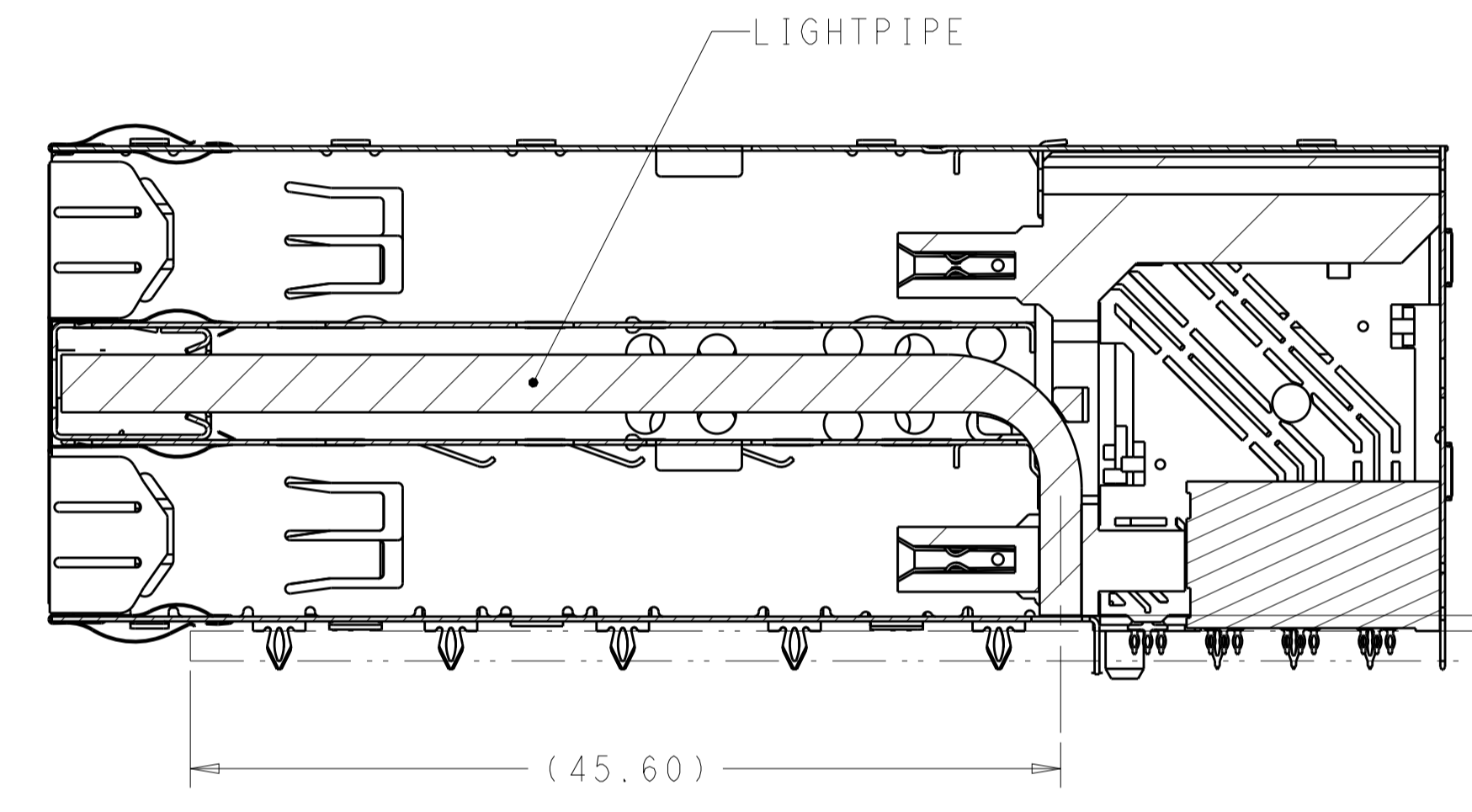

SECTION V-V
 SCALE 3:1

(0.81)
 RECOMMENDED 0805
 PACKAGE SMD CHIP
 LED LAMPS

1.57 MIN PCB

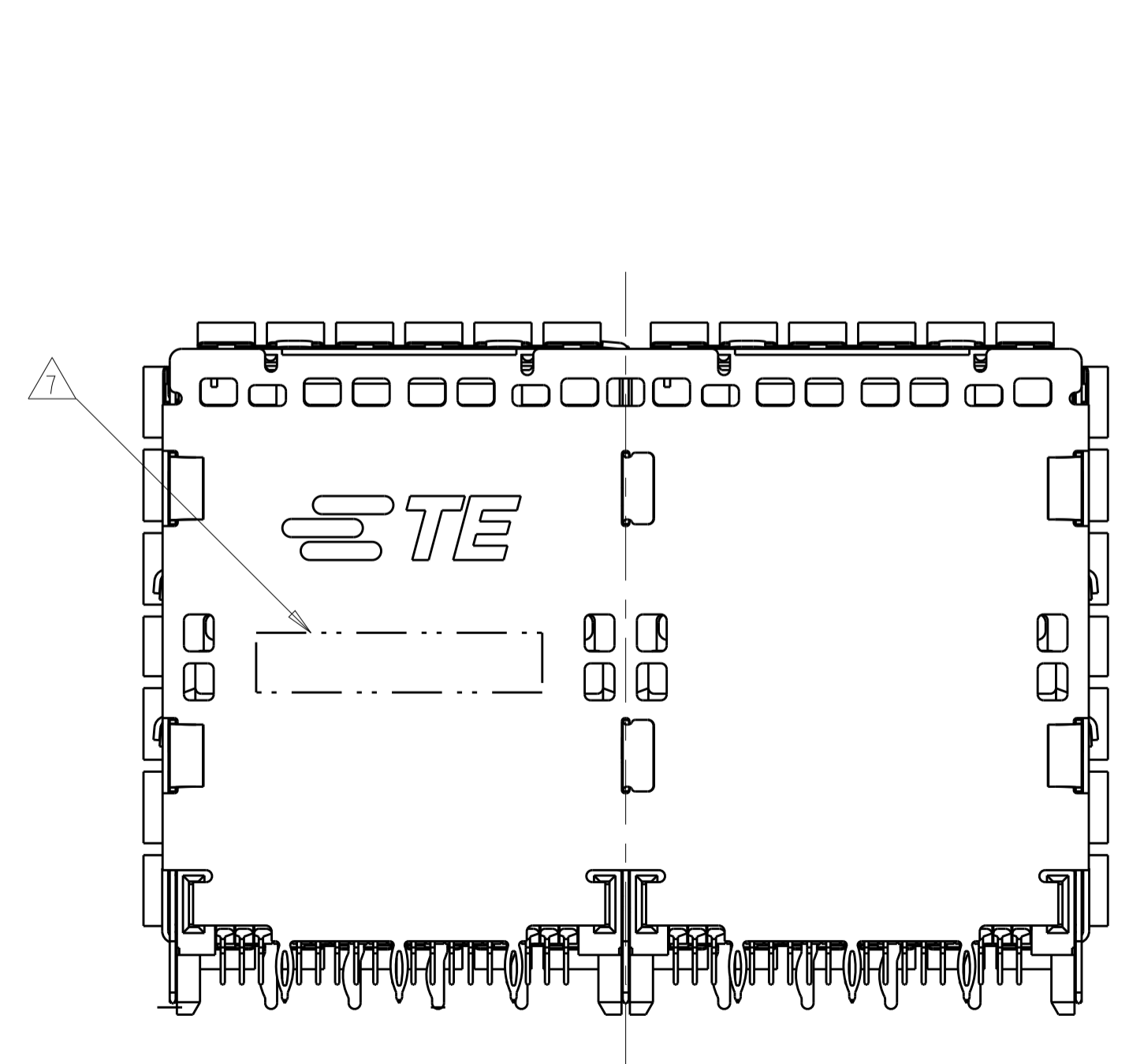

VIEW Y-Y

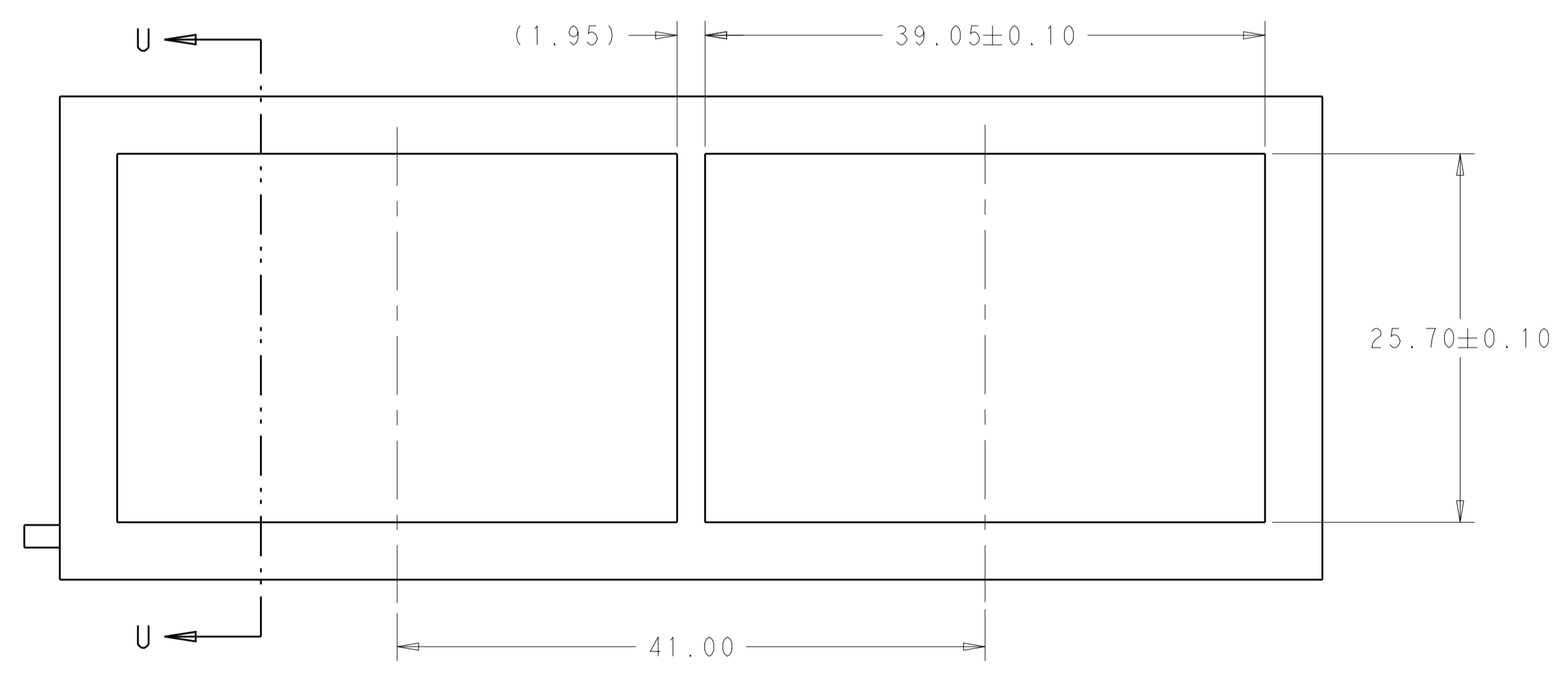

RECOMMENDED PANEL CUTOUT
 AND PC BOARD, PANEL POSITION
 SCALE 3:1

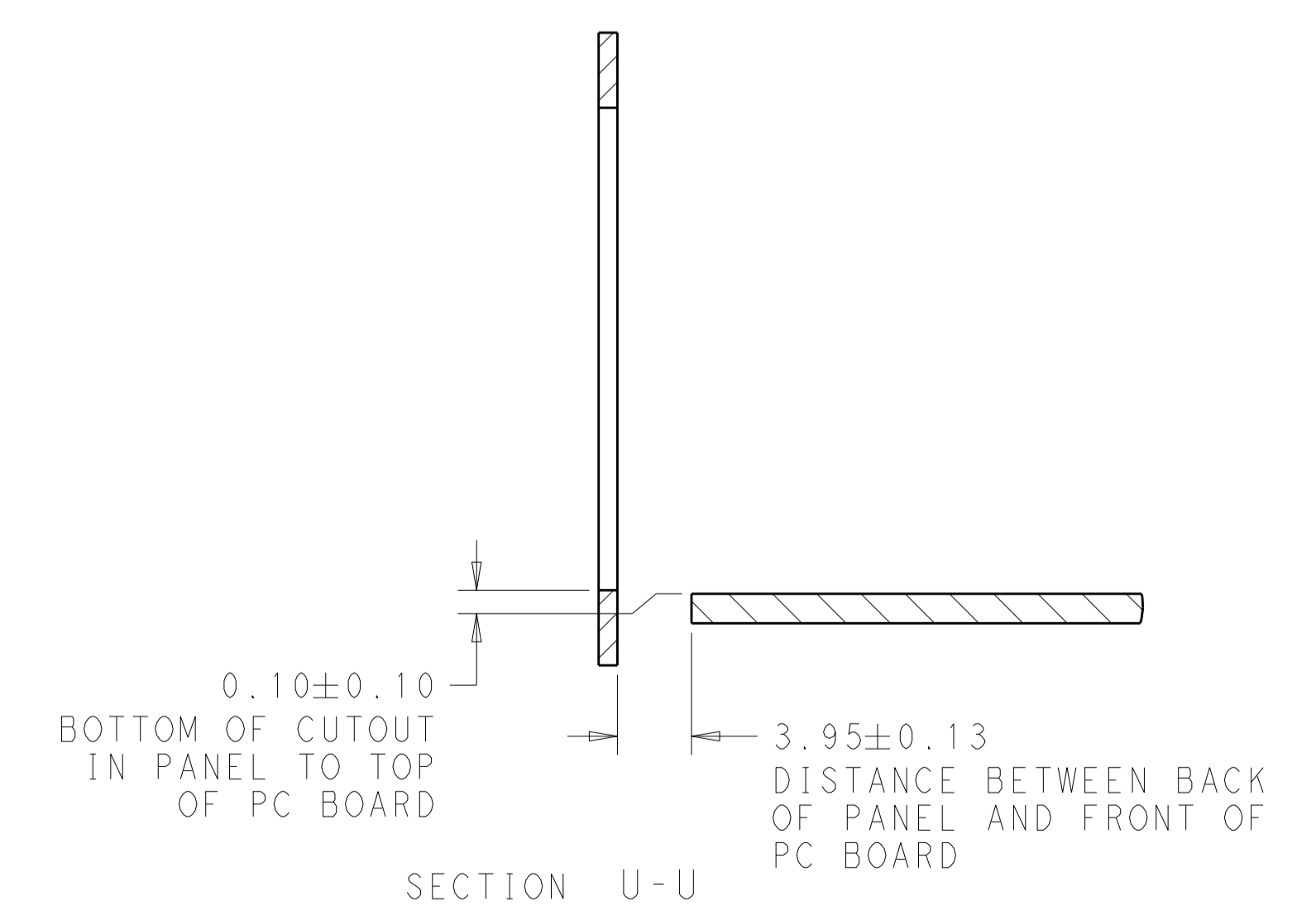

0.10±0.10
 BOTTOM OF CUTOUT
 IN PANEL TO TOP
 OF PC BOARD

3.95±0.13
 DISTANCE BETWEEN BACK
 OF PANEL AND FRONT OF
 PC BOARD

SECTION U-U

THIS DRAWING IS A CONTROLLED DOCUMENT.		DMN M. SHIRK 18JAN2013	TE Connectivity NAME CAGE AND CONNECTOR ASSEMBLY, WITH EMI SPRING, THRU BEZEL, 2X2, ZQSPF+ STACKED
DIMENSIONS:		CHK D. SZCZESNY 18JAN2013	
mm	0 PLC ±	PRODUCT SPEC	SIZE CAGE CODE DRAWING NO A100779C=2227670
	1 PLC ±0.25	108-60102	
	2 PLC ±0.15	APPLICATION SPEC	RESTRICTED TO
	3 PLC ±	114-60015	
	4 PLC ±	WEIGHT	
	ANGLES ±	CUSTOMER DRAWING	
MATERIAL	FINISH	SCALE 4:1	SHEET 2 OF 4
SEE NOTE 1	SEE NOTE 2		REV B

REVISONS		DATE	OWN	APVD
P. LTR	DESCRIPTION			
-	SEE SHEET 1	-	-	-

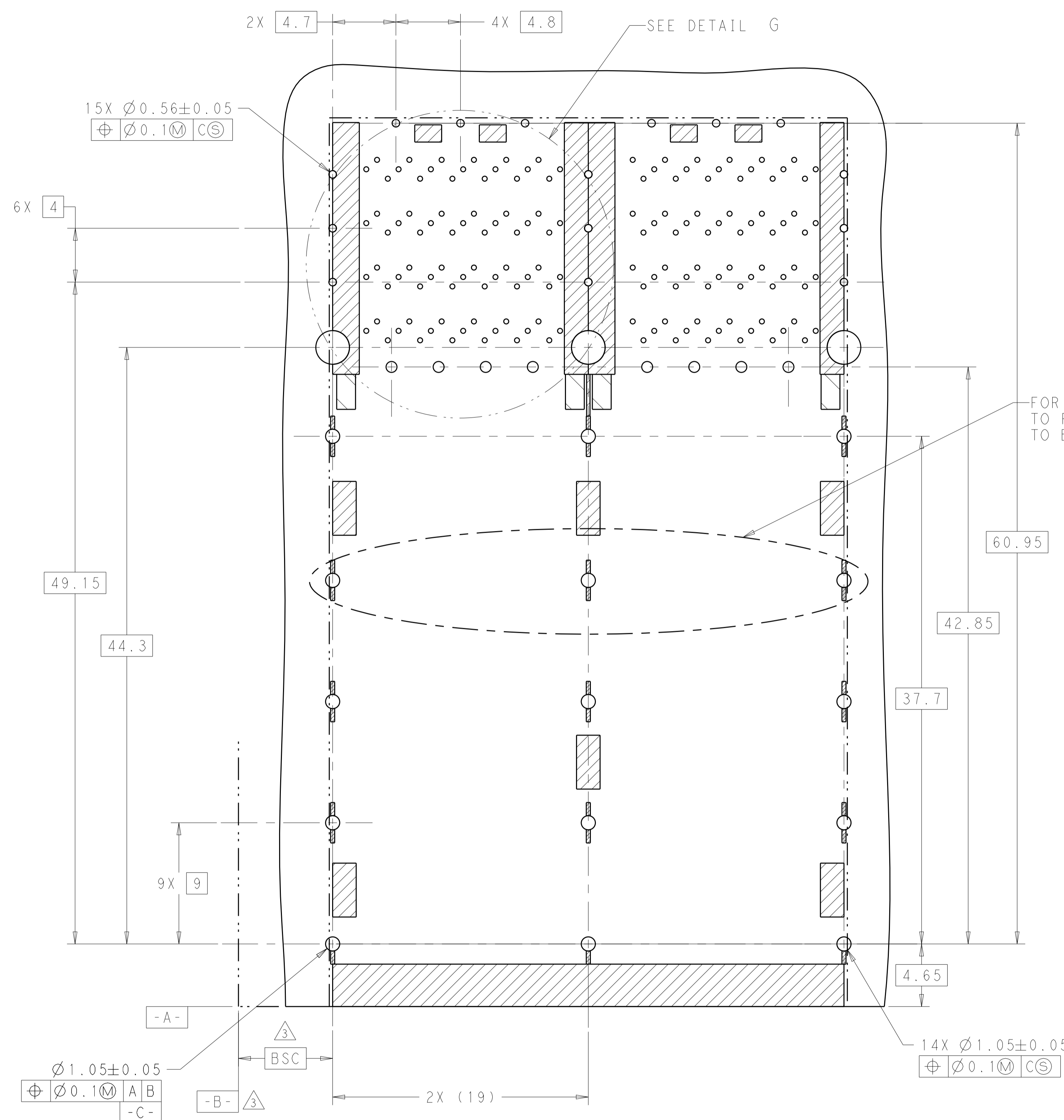

RECOMMENDED PC BOARD LAYOUT
 COMPONENT SIDE OF BOARD
 (PCB TOLERANCE ± 0.05)
 SCALE 5:1

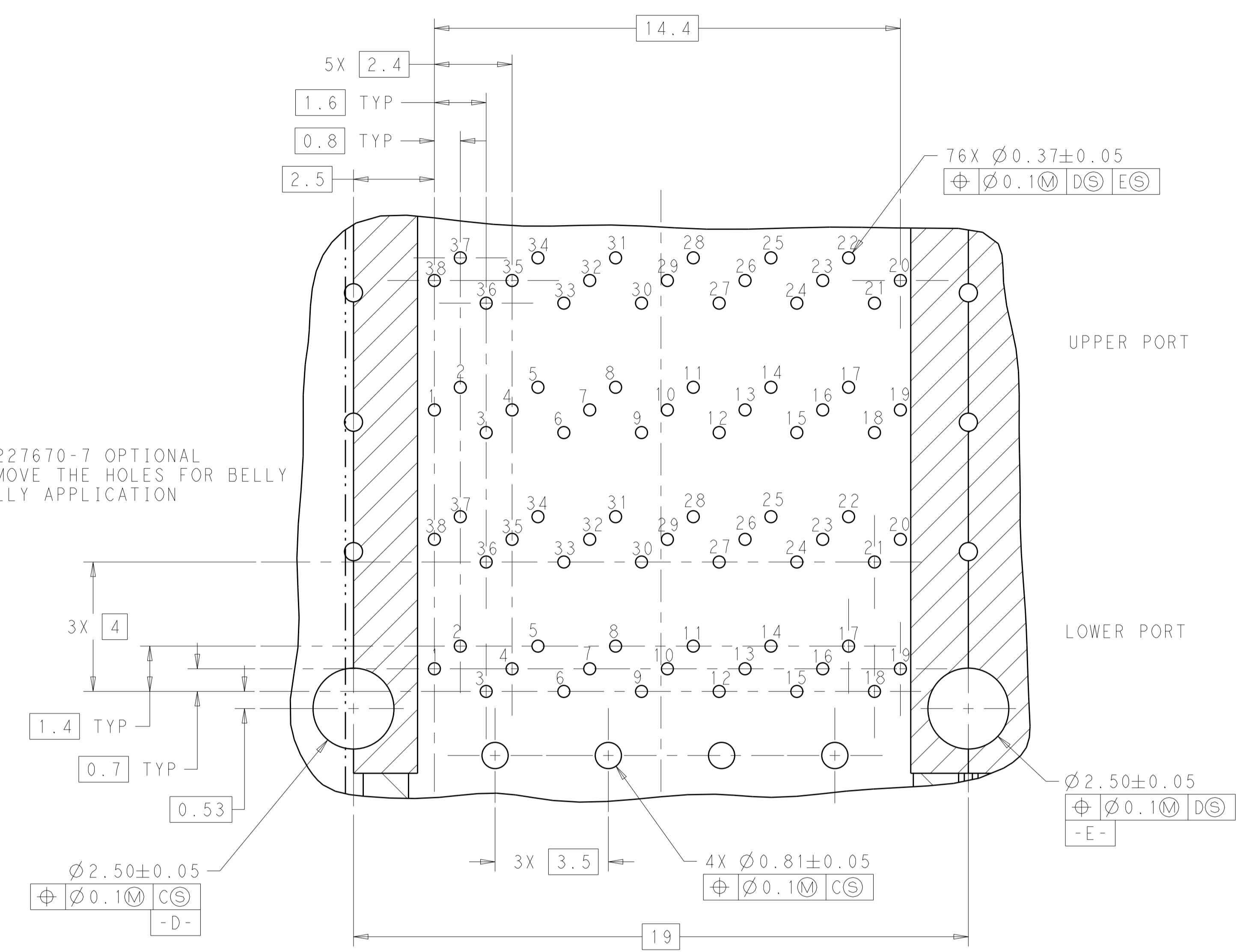

DETAIL G
 SCALE 10:1

FOR 2227670-7 OPTIONAL
 TO REMOVE THE HOLES FOR BELLY
 TO BELLY APPLICATION

THIS DRAWING IS A CONTROLLED DOCUMENT.		OWN: M. SHIRK 18JAN2013	TE Connectivity
DIMENSIONS: mm		CHK: D. SZCZESNY 18JAN2013	
TOLERANCES UNLESS OTHERWISE SPECIFIED:		APVD: -	NAME: CAGE AND CONNECTOR ASSEMBLY, WITH EMI SPRING, THRU BEZEL, 2X2, ZQSFP+ STACKED
0 PLC \pm	1 PLC ± 0.25	PRODUCT SPEC: 108-60102	SIZE: CAGE CODE DRAWING NO: A100779C=2227670
2 PLC ± 0.15	3 PLC \pm	APPLICATION SPEC: 114-60015	RESTRICTED TO: -
4 PLC \pm	ANGLES \pm	WEIGHT: -	SCALE: 4:1 SHEET 3 OF 4 REV B
MATERIAL: -	FINISH: -	CUSTOMER DRAWING	
SEE NOTE 1	SEE NOTE 2		

LOC		DIST		REVISIONS			
P.	LTN.	DESCRIPTION	DATE	DWN.	APVD.		
-	-	SEE SHEET 1	-	-	-	-	-

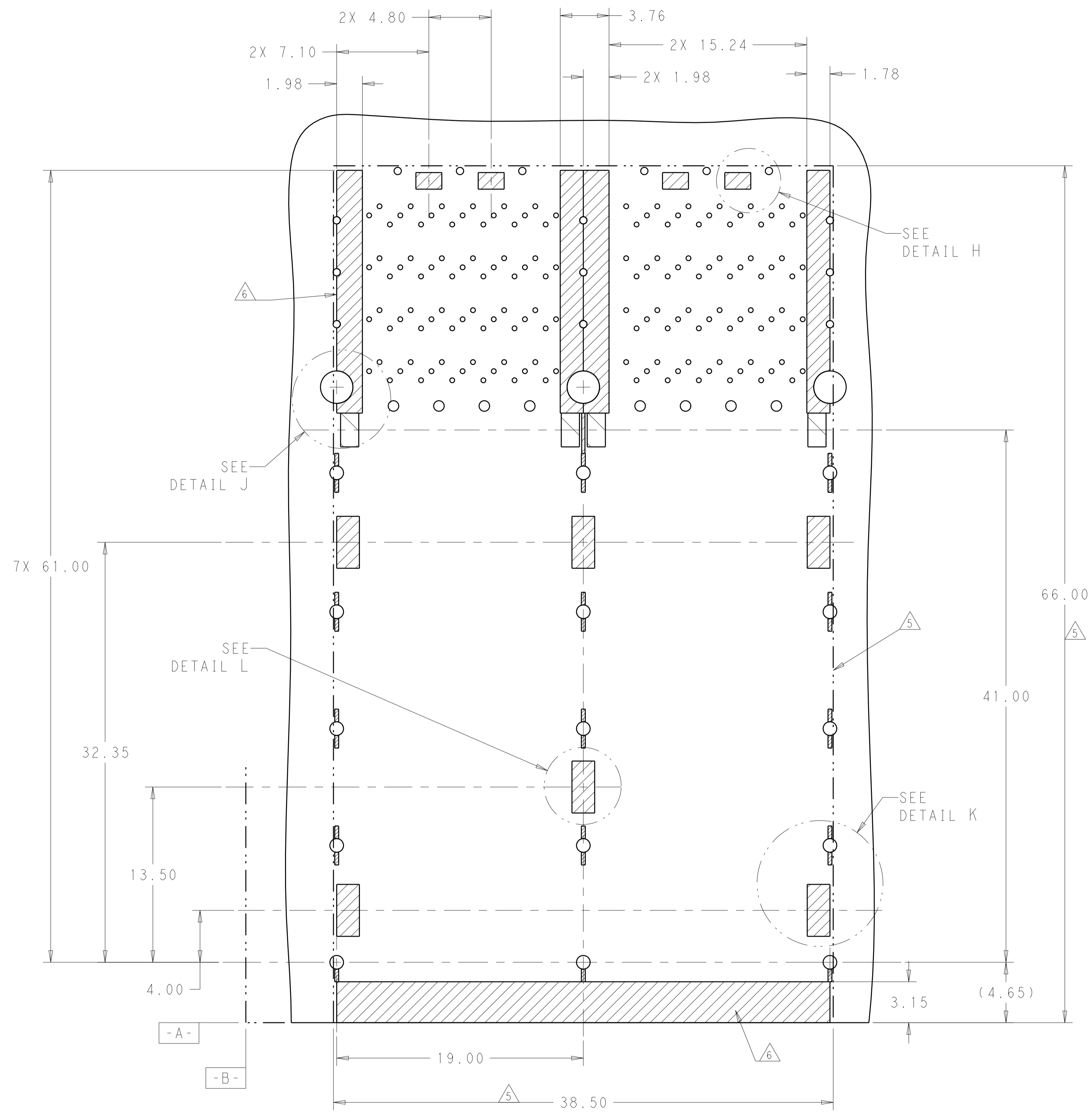

KEEPOUT AREAS
 COMPONENT SIDE OF BOARD
 (PCB TOLERANCE ±0.05)
 SCALE 5:1

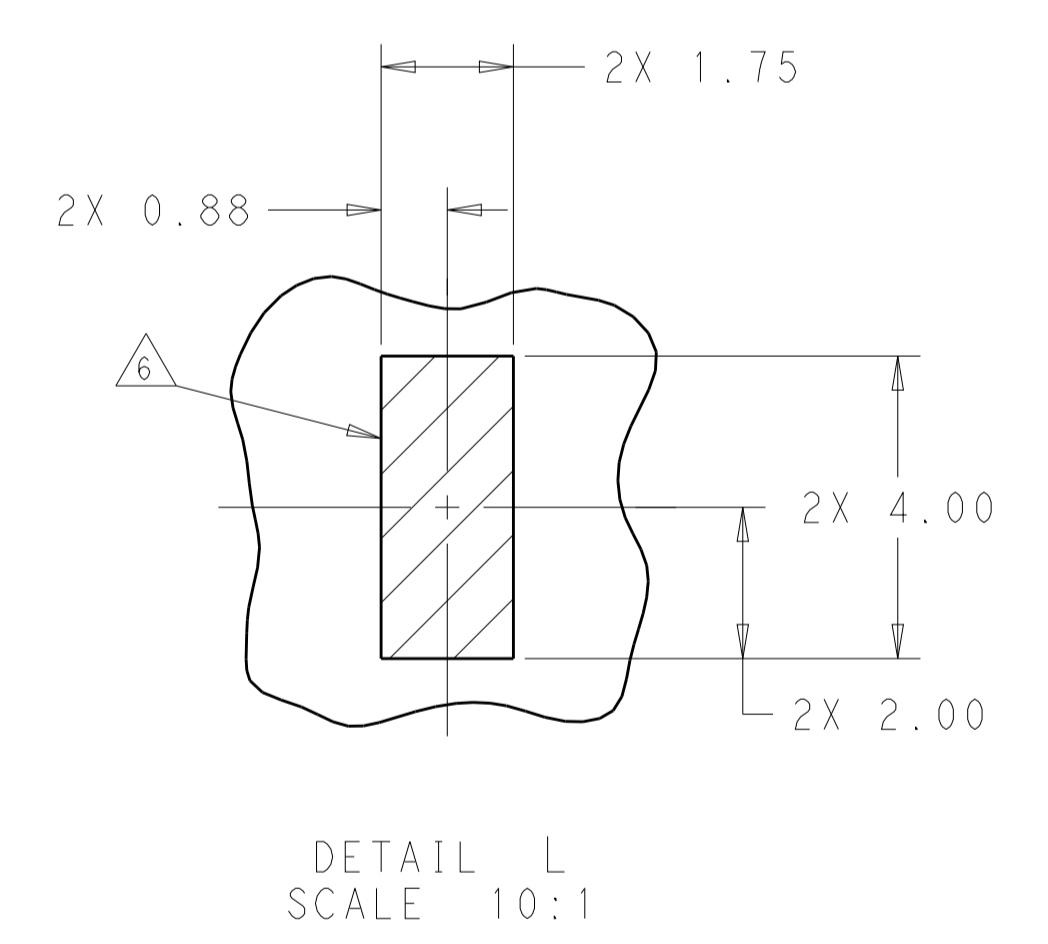
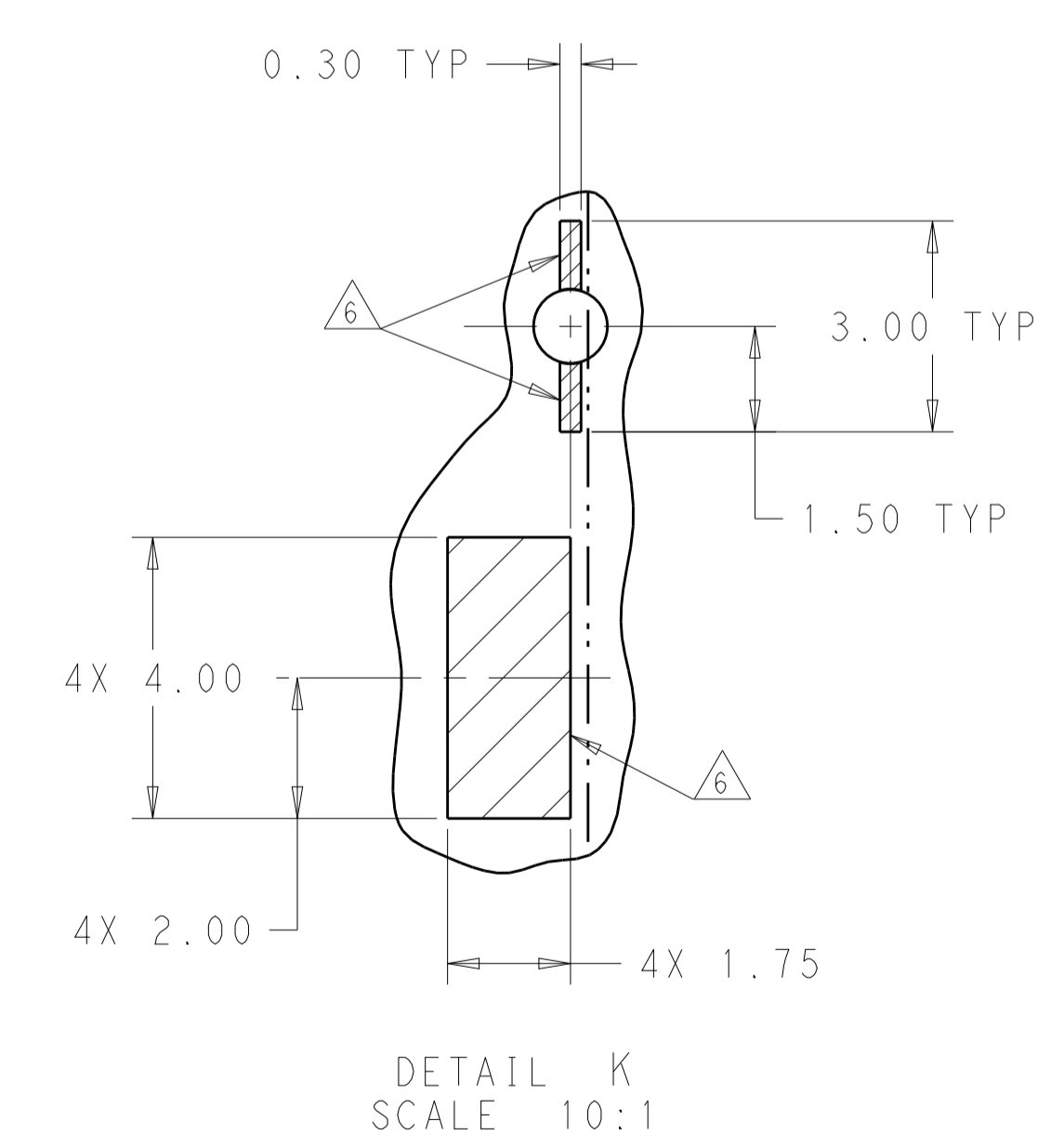
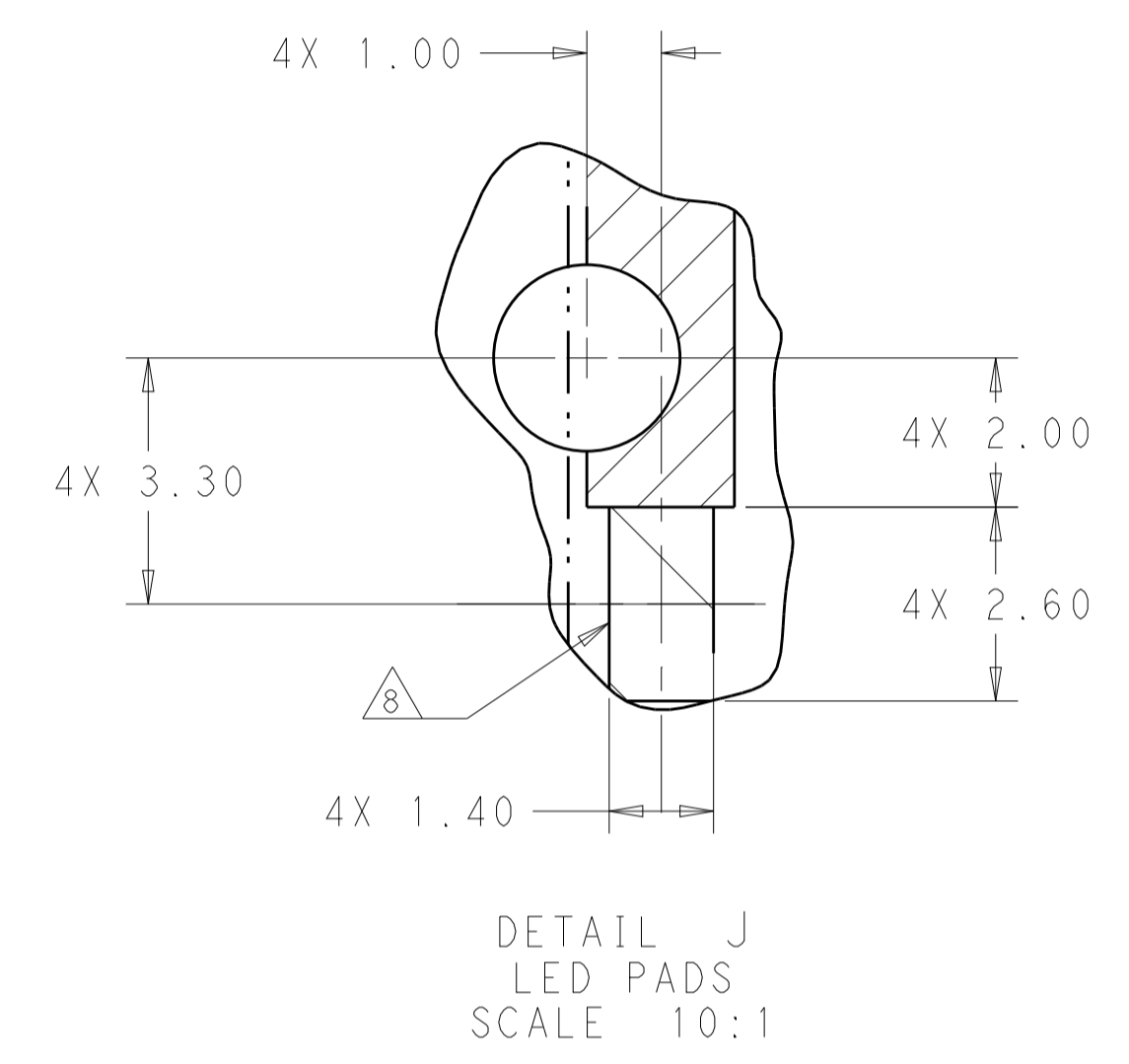
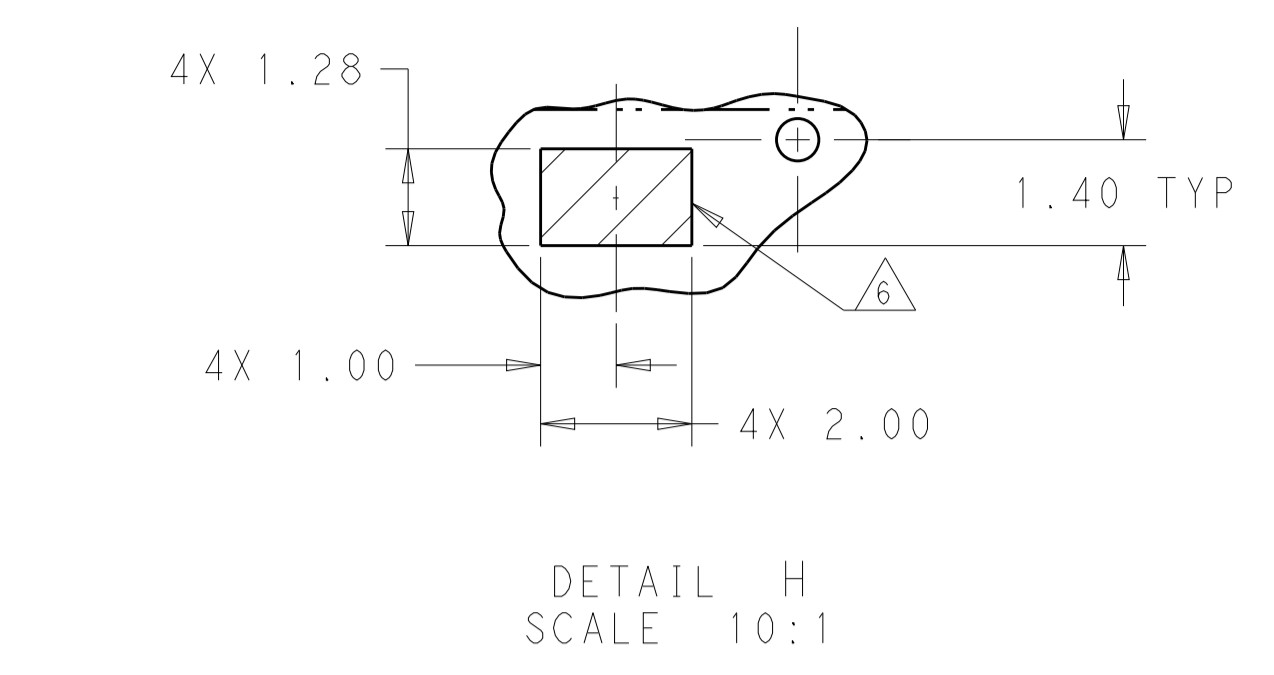

THIS DRAWING IS A CONTROLLED DOCUMENT.		DWN: M. SHIRK 18JAN2013	TE Connectivity
		CHK: D. SZCZESNY 18JAN2013	
DIMENSIONS:	TOLERANCES UNLESS OTHERWISE SPECIFIED:	APVD:	NAME:
mm	0 PLC ±	PRODUCT SPEC	CAGE AND CONNECTOR ASSEMBLY,
	1 PLC ±0.25	108-60102	WITH EMI SPRING, THRU BEZEL, 2X2,
	2 PLC ±0.15	APPLICATION SPEC	ZQSP+ STACKED
	3 PLC ±	SIZE: 114-60015	RESTRICTED TO:
	4 PLC ±	WEIGHT:	A100779C=2227670
	ANGLES ±	CUSTOMER DRAWING	SCALE 4:1 SHEET 4 OF 4 REV B
MATERIAL:	FINISH:		
SEE NOTE 1	SEE NOTE 2		