



Chipsmall Limited consists of a professional team with an average of over 10 year of expertise in the distribution of electronic components. Based in Hongkong, we have already established firm and mutual-benefit business relationships with customers from,Europe,America and south Asia,supplying obsolete and hard-to-find components to meet their specific needs.

With the principle of “Quality Parts,Customers Priority,Honest Operation,and Considerate Service”,our business mainly focus on the distribution of electronic components. Line cards we deal with include Microchip,ALPS,ROHM,Xilinx,Pulse,ON,Everlight and Freescale. Main products comprise IC,Modules,Potentiometer,IC Socket,Relay,Connector.Our parts cover such applications as commercial,industrial, and automotives areas.

We are looking forward to setting up business relationship with you and hope to provide you with the best service and solution. Let us make a better world for our industry!



Contact us

Tel: +86-755-8981 8866 Fax: +86-755-8427 6832

Email & Skype: info@chipsmall.com Web: www.chipsmall.com

Address: A1208, Overseas Decoration Building, #122 Zhenhua RD., Futian, Shenzhen, China



6.2 x 3.5mm Compact Tactile Switch

Features

Optimized Mechanical Features

- Surface mount terminal configuration
- Compatible with IR reflow and manual soldering
- Variety of operating force options

Optimized Contact System

- Excellent tactile feedback

Materials

- Silver coated terminals for better solderability
- High temperature materials (UL94V-0)
- RoHS compliant

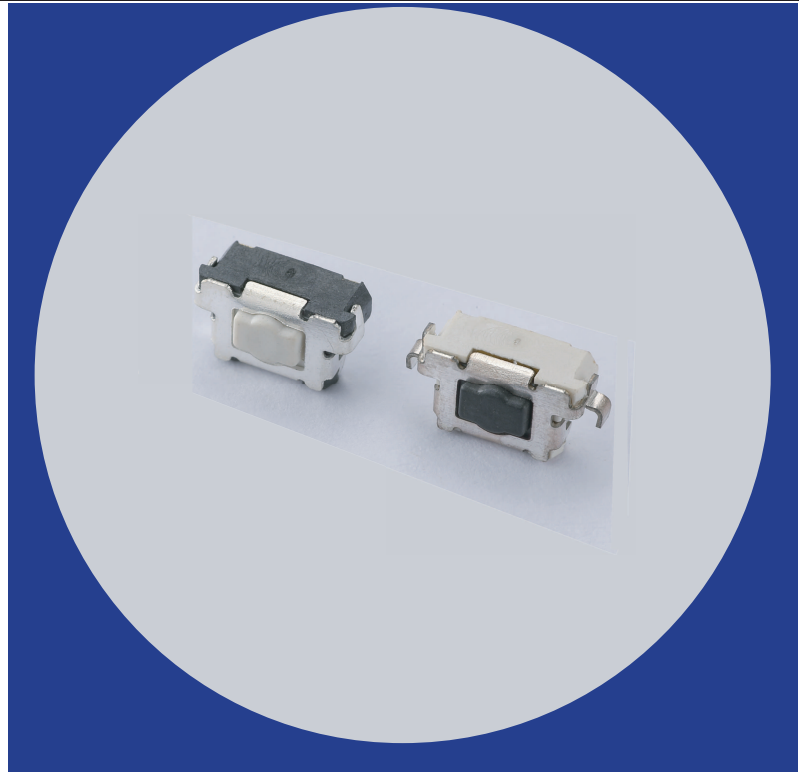

Electrical and Mechanical Specifications

Switch Contact Resistance

100 milliohms maximum

Insulation Resistance

100 Megohms minimum between terminals

Maximum Rating

50mA, 12 VDC

Dielectric Strength

250 VAC for 1 minute between adjacent terminals

Operating Force

120, 160 or 240 gf

Travel

0.15mm

Operating Temperature

- 40°C to +85°C

Storage Temperature

- 40°C to +85°C

Actuator Strength

3 Kgf maximum

Actuation Life

120 gf: 1,000,000 cycles

160 gf: 1,000,000 cycles

240 gf: 500,000 cycles

Allowable Solder Time

IR Reflow: Up to 5 seconds at 260°C.

Manual soldering: Up to 3 seconds at 350°C

Packaging

Standard: Tape and reel packaging with 330mm diameter reel and 12mm wide plastic tape

CTS SERIES 222H... - Surface Mount Without Bracket

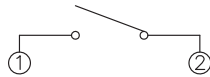
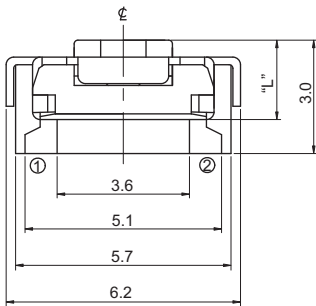
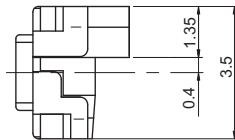
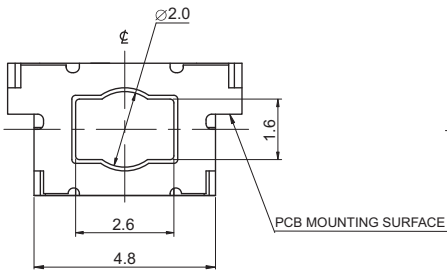
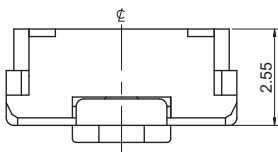

CIRCUIT DIAGRAM

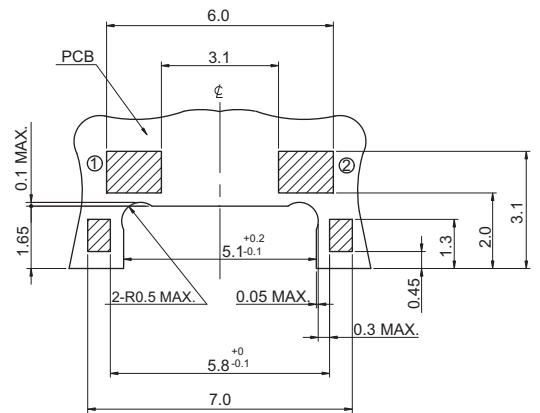

PCB LAYOUT

DIMENSION : mm
STANDARD TOLERANCE :
.X (1 PLACE) : ± 0.2

CTS SERIES 222H...K - Surface Mount With Bracket

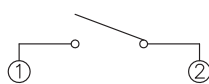
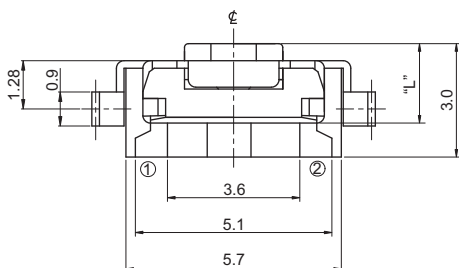
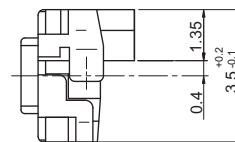
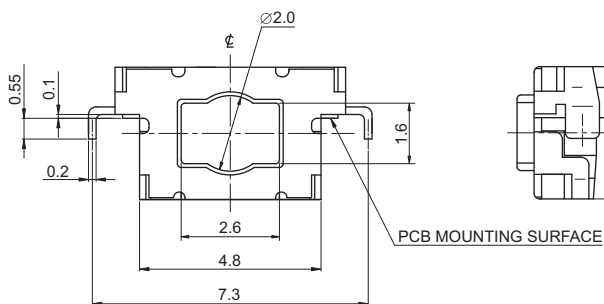
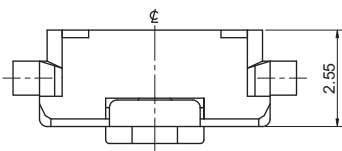

CIRCUIT DIAGRAM

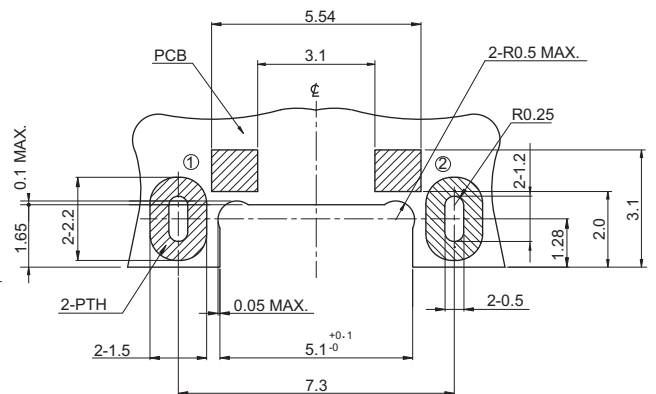

DIMENSION : mm
STANDARD TOLERANCE :
.X (1 PLACE) : ± 0.2

Ordering Information

