



Chipsmall Limited consists of a professional team with an average of over 10 year of expertise in the distribution of electronic components. Based in Hongkong, we have already established firm and mutual-benefit business relationships with customers from,Europe,America and south Asia,supplying obsolete and hard-to-find components to meet their specific needs.

With the principle of "Quality Parts,Customers Priority,Honest Operation,and Considerate Service",our business mainly focus on the distribution of electronic components. Line cards we deal with include Microchip,ALPS,ROHM,Xilinx,Pulse,ON,Everlight and Freescale. Main products comprise IC,Modules,Potentiometer,IC Socket,Relay,Connector.Our parts cover such applications as commercial,industrial, and automotives areas.

We are looking forward to setting up business relationship with you and hope to provide you with the best service and solution. Let us make a better world for our industry!



Contact us

Tel: +86-755-8981 8866 Fax: +86-755-8427 6832

Email & Skype: info@chipsmall.com Web: www.chipsmall.com

Address: A1208, Overseas Decoration Building, #122 Zhenhua RD., Futian, Shenzhen, China



THIS DRAWING AND THE SUBJECT MATTER SHOWN THEREON ARE CONFIDENTIAL AND THE PROPERTY OF BEL/STEWART/TRP CONNECTOR AND SHALL NOT BE REPRODUCED, COPIED, OR USED IN ANY MANNER WITHOUT THE WRITTEN CONSENT OF TRP CONNECTOR.

PRODUCT MAY BE PROTECTED BY ONE OR MORE OF THE FOLLOWING US PATENTS:
 5736910 5939955 6425781 6428361 6554638 6840817 7123117
 7429195 7717749 7808751 6217391 6149050 7924130

REVISIONS				
P	LTR	DESCRIPTION	DATE	APVD
1		INITIAL RELEASE	17APR2017	TRY TYY

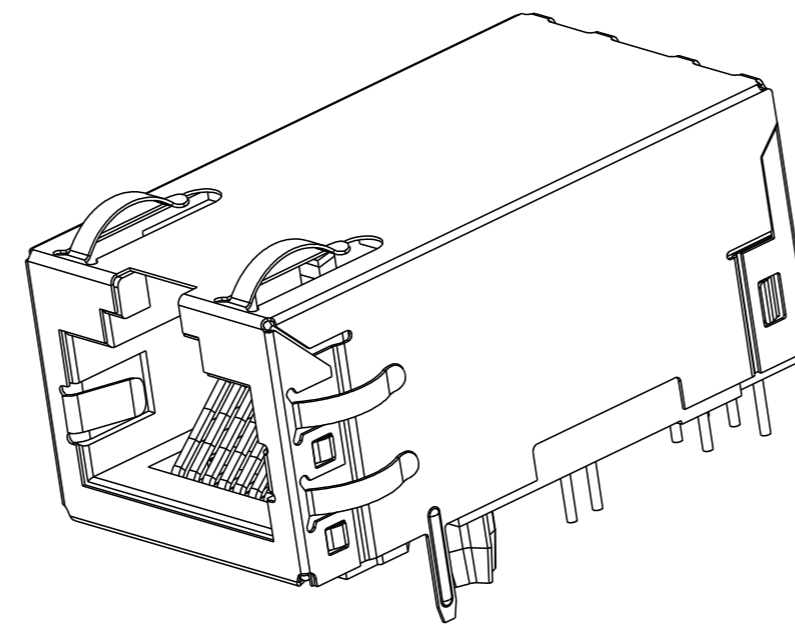
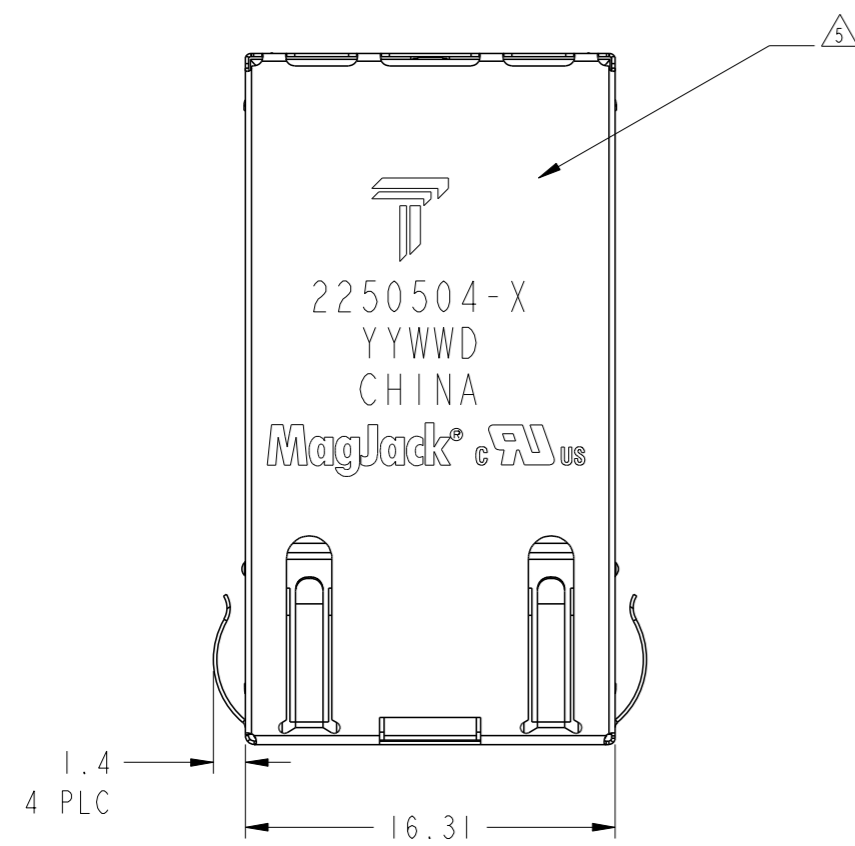

1. MATERIALS
 HOUSING: THERMOPLASTIC, BLACK, FLAMMABILITY RATING UL 94V-0
 SHIELD: STAINLESS STEEL, 0.15mm THICK, PREPLATED WITH MIN 0.76μm SEMI-BRIGHT NICKEL POST DIPPED WITH 2.54μm MIN SAC SOLDER AT GROUND PINS.
 CONTACT: PHOSPHOR BRONZE, 0.46mmX0.30mm WITH 1.27μm MIN OVERALL NICKEL UNDERPLATE AND SELECTIVE 1.27μm MIN GOLD PLATING AT MATING INTERFACE.
 SOLDER TAIL(LED AND SIGNAL): Ø0.45mm COPPER PLATED STEEL, PLATED WITH 2.54μm MIN TIN.

- △ MAGNETICS
 -APPLICATION: 2.5G BASE-T 4PPoE EXTENDED TEMPERATURE
 -IMPEDANCE: 100 OHMS
 -TURNS RATIO (CHIP:CABLE): 1:1 ALL FOUR PAIRS
 -OPEN CIRCUIT INDUCTANCE (OCL): ALL CHANNELS 180uH MIN @100kHz, 0.1VRMS, 8mA DC BIAS FROM -40°C TO 85°C, 120uH MIN @100kHz, 0.1VRMS, 23mA DC BIAS FROM -40°C TO 85°C, ALL FOUR PAIRS.
 -ALL FOUR PAIRS BI-DIRECTIONAL
 -PoE CURRENT: 900mADC MAX
 -PERFORMANCE @ 25°C: PLEASE REFER TO SEPARATE SHEET
 -ISOLATION VOLTAGE: 2250VDC FOR 60 SECONDS WITH A RISE TIME OF 500V/SEC.

3. OPERATING TEMPERATURE: -40°C TO 85°C
 △ RJ45 CAVITY CONFORMS TO FCC RULES AND REGULATION PART 68 SUBPART F.
 △ TRP CONNECTOR LOGO, PART NUMBER, DATE CODE, COUNTRY OF ORIGIN, AGENCY APPROVAL MARKING IN APPROPRIATE LOCATION SHOWN. DATE CODE: YYWW "YY" IS YEAR, "WW" IS WORK WEEK, "D" IS DAY OF WEEK, WITH SUNDAY=1.
 △ PART SHOULD BE RECOMMENDED FOR WAVE SOLDERING PROCESS, PEAK SOLDERING TEMPERATURE IS 260°C, 10 SECONDS MAX.

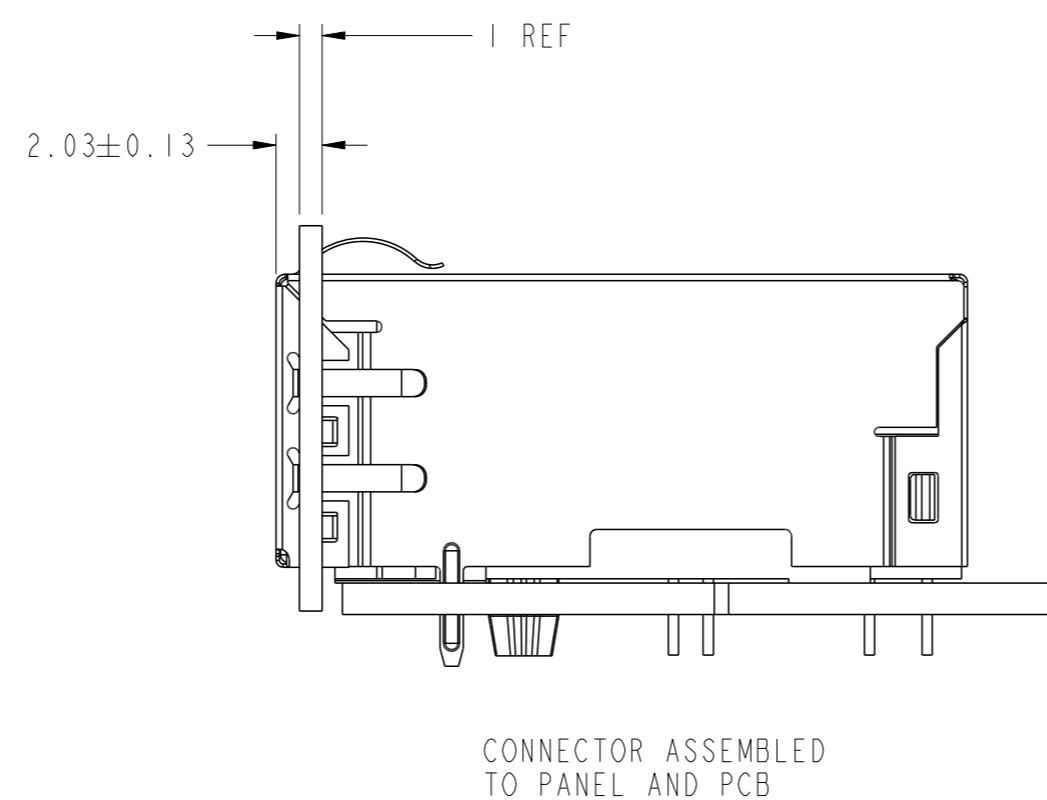
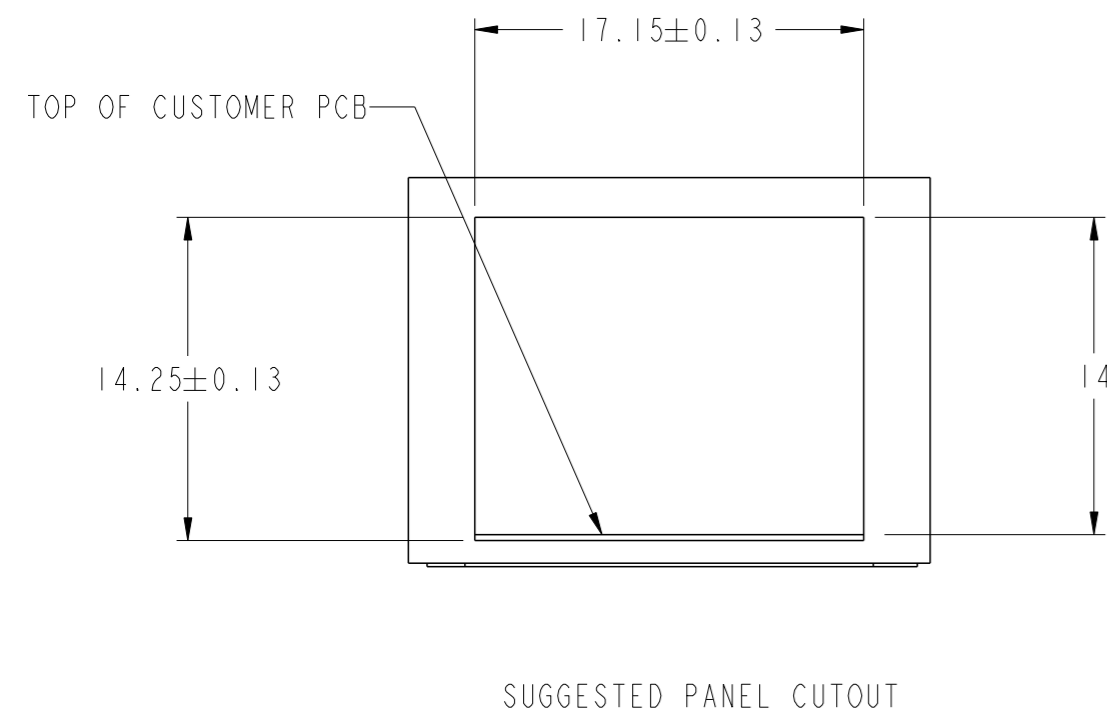
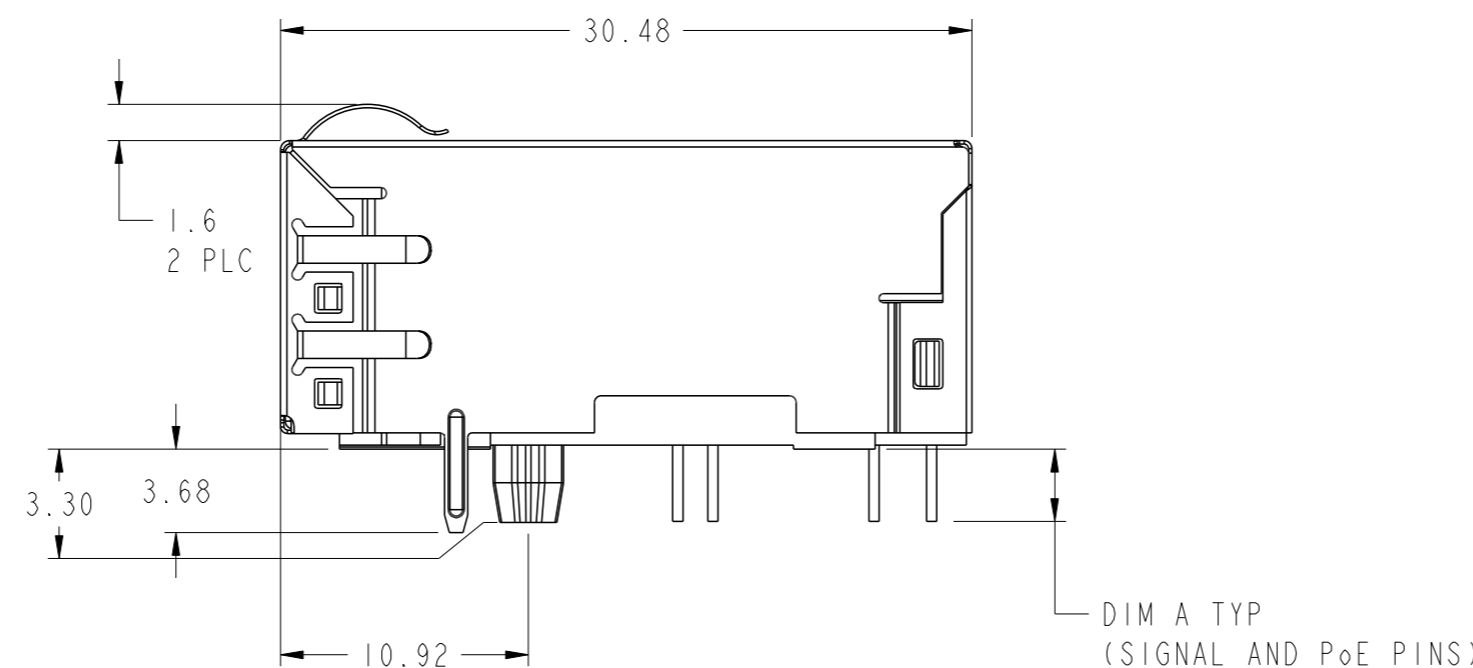
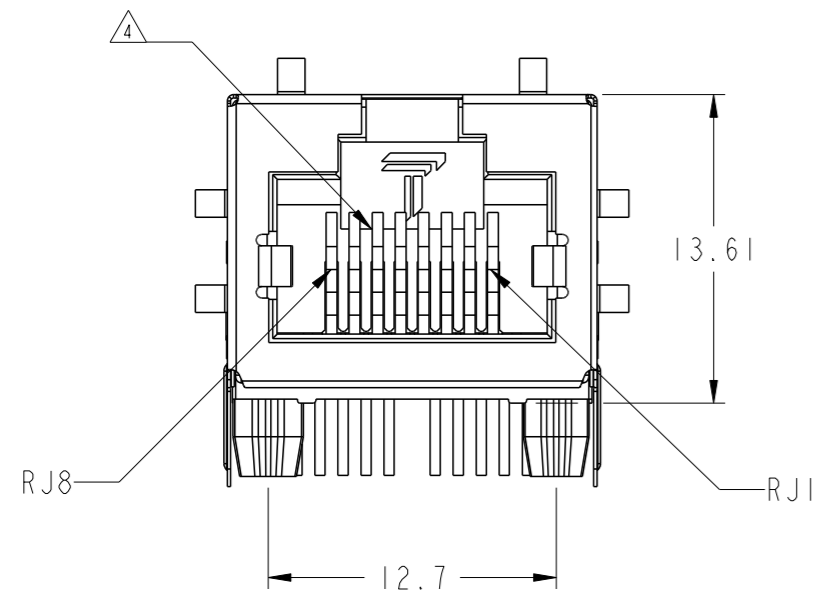

TRAY	WAVE △	3.18	2250504-1
PACKAGE	SOLDER PROCESS	DIM A	PART NUMBER

THIS DRAWING IS A CONTROLLED DOCUMENT, AND COMPLIANT TO ASME Y14.5M		DWN TOWER YU / XENIA WANG 17APR2017	 trp CONNECTOR a bel group DONGGUAN CHINA	
DIMENSIONS: mm		CHK BILL LIU 17APR2017		
TOLERANCES UNLESS OTHERWISE SPECIFIED:		APVD TONY YUAN 17APR2017	DESC 1X1 7UQTO1ET 2.5G 4PPoE 100W EXTENDED TEMP TAB UP, W/O LEDS	
0 PLC ± 1 PLC ±0.25 2 PLC ±0.25 3 PLC ±0.25 4 PLC ± ANGLES ± APPLICATION SPEC		MODEL NAME MAGJACK SINGLE 4PPOE	SIZE A2	RESTRICTED TO -
PRODUCT SPEC		DRAWING NO C-2250504		SCALE NTS
-		CUSTOMER DRAWING		SHEET 1 OF 3

7UQT01ET 2.5G 100W CIRCUIT

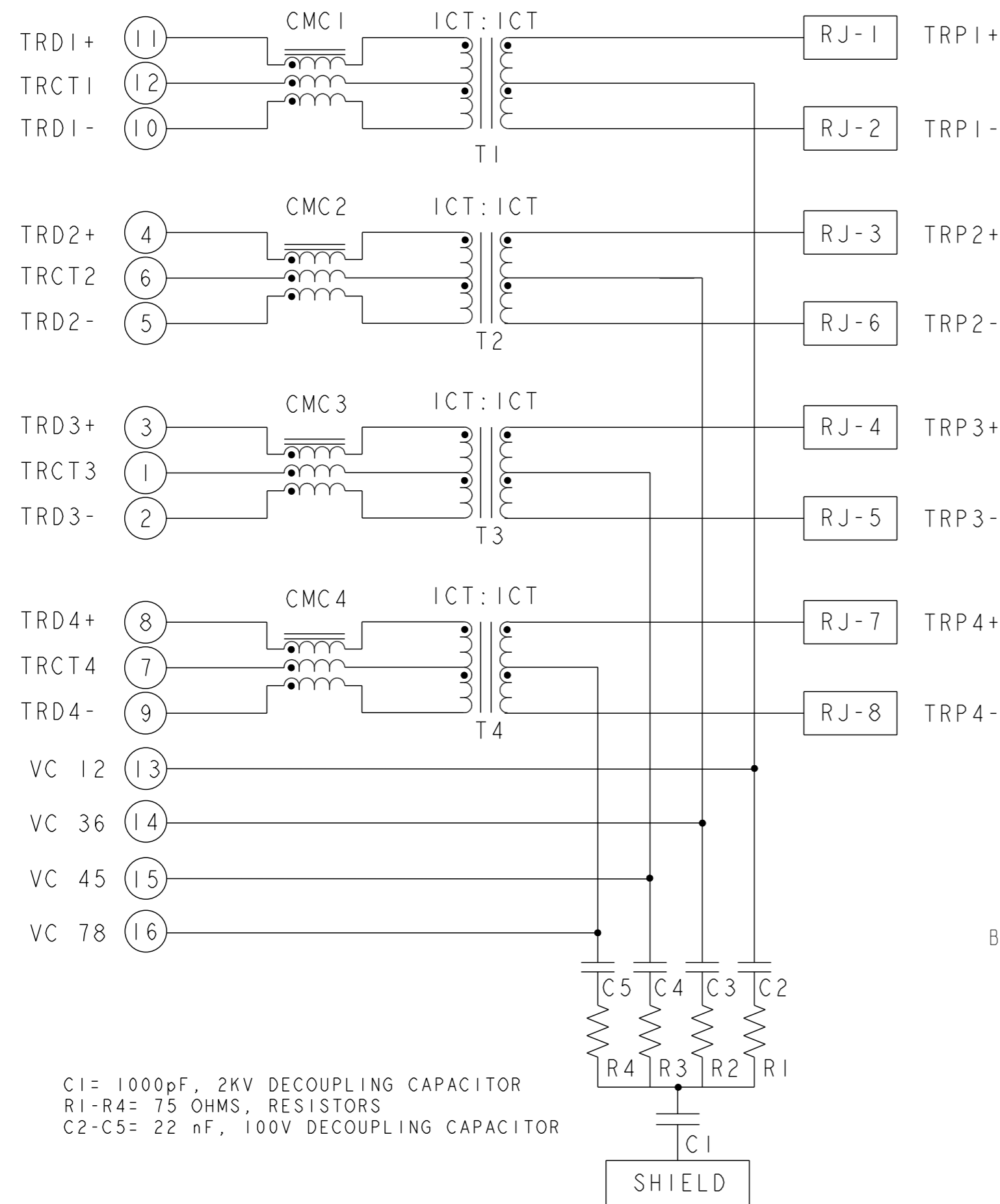

C1= 1000pF, 2KV DECOUPLING CAPACITOR
 R1-R4= 75 OHMS, RESISTORS
 C2-C5= 22 nF, 100V DECOUPLING CAPACITOR

THE SHADED AREA OF CUSTOMER PC BOARD IS EQUIVALENT TO RJ CABLE SIDE PINS, IT IS RECOMMENDED THAT AREA TO BE CLEAR OF ANY COMPONENTS, VIA HOLES AND TRACES TO AVOID HI-POT FAILURE

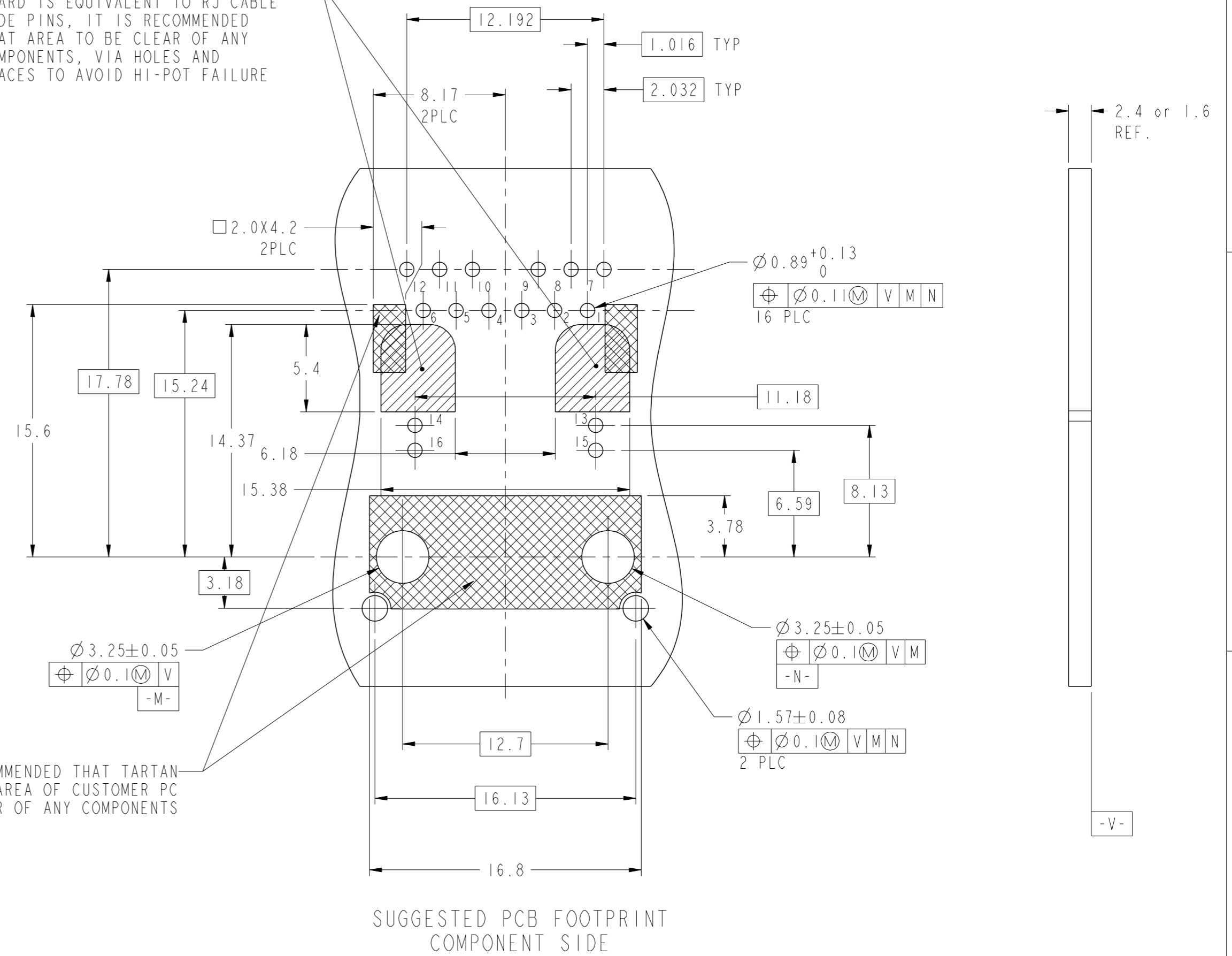

IT IS RECOMMENDED THAT TARTAN SHADING AREA OF CUSTOMER PC BOARD BE CLEAR OF ANY COMPONENTS

SUGGESTED PCB FOOTPRINT COMPONENT SIDE

THIS DRAWING IS A CONTROLLED DOCUMENT, AND COMPLIANT TO ASME Y14.5M		DWN TOWER YU / XENIA WANG 17APR2017	trp CONNECTOR a bel group DONGGUAN CHINA	
DIMENSIONS: mm		CHK BILL LIU 17APR2017		
TOLERANCES UNLESS OTHERWISE SPECIFIED:		APVD TONY YUAN 17APR2017	DESC 1X1 7UQT01ET 2.5G 4PPoE 100W EXTENDED TEMP TAB UP, W/O LEDS	
0 PLC ± 1 PLC ±0.25 2 PLC ±0.25 3 PLC ±0.25 4 PLC ± ANGLES ± APPLICATION SPEC		MODEL NAME MAGJACK SINGLE 4POE	SIZE A2	DRAWING NO C-2250504
PRODUCT SPEC		CUSTOMER DRAWING		RESTRICTED TO -
		SCALE NTS	SHEET 2	OF 3
				REV 1

2250504_C						STOCK DISPOSITION			
						A:CONTINUE AS IS B:REWORK C:SCRAP		D:USE OLD FIRST E:PARTS TO CONFORM F:OTHER	
REVISION HISTORY									
DATE	REV	CHANGE	REASON	APPROVAL	INVENTORY (A,B,C,D,E,F)	WORK IN PROCESS (A,B,C,D)	SUPPLIER ORDERS (A,E,F)	OPEN CUST ORDERS (A,E,F)	
17APR2017	I	-	INITIAL RELEASE	TONY YUAN	-	-	-	-	
					-	-	-	-	

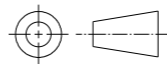
THIS DRAWING IS A CONTROLLED DOCUMENT. AND COMPLIANT TO ASME Y14.5M		DWN TOWER YU / XENIA WANG 17APR2017	 trp CONNECTOR a bel group	DONGGUAN CHINA	
DIMENSIONS: mm		CHK BILL LIU 17APR2017		DESC 1X1 7UQT01ET 2.5G 4PPoE 100W EXTENDED TEMP TAB UP, W/O LEDS	
		APVD TONY YUAN 17APR2017	SIZE A2	CAGE CODE C-2250504	RESTRICTED TO -
TOLERANCES UNLESS OTHERWISE SPECIFIED: 0 PLC ± 1 PLC ±0.25 2 PLC ±0.25 3 PLC ±0.25 4 PLC ± ANGLES ±		MODEL NAME MAGJACK SINGLE 4PPOE	DRAWING NO C-2250504		
PRODUCT SPEC -		APPLICATION SPEC -		CUSTOMER DRAWING	
			SCALE NTS	SHEET 3	OF 3
			REV 1		