



Chipsmall Limited consists of a professional team with an average of over 10 year of expertise in the distribution of electronic components. Based in Hongkong, we have already established firm and mutual-benefit business relationships with customers from,Europe,America and south Asia,supplying obsolete and hard-to-find components to meet their specific needs.

With the principle of "Quality Parts,Customers Priority,Honest Operation,and Considerate Service",our business mainly focus on the distribution of electronic components. Line cards we deal with include Microchip,ALPS,ROHM,Xilinx,Pulse,ON,Everlight and Freescale. Main products comprise IC,Modules,Potentiometer,IC Socket,Relay,Connector.Our parts cover such applications as commercial,industrial, and automotives areas.

We are looking forward to setting up business relationship with you and hope to provide you with the best service and solution. Let us make a better world for our industry!



Contact us

Tel: +86-755-8981 8866 Fax: +86-755-8427 6832

Email & Skype: info@chipsmall.com Web: www.chipsmall.com

Address: A1208, Overseas Decoration Building, #122 Zhenhua RD., Futian, Shenzhen, China



THIS DRAWING IS UNPUBLISHED. RELEASED FOR PUBLICATION
 © COPYRIGHT - By - ALL RIGHTS RESERVED.

LOC		DIST		REVISIONS			
P	LTR	DESCRIPTION		DATE	DWN	APVD	
	D	REV PER ECO 15-017024		11-25-15	CT	WM	

ASSEMBLED VIEW

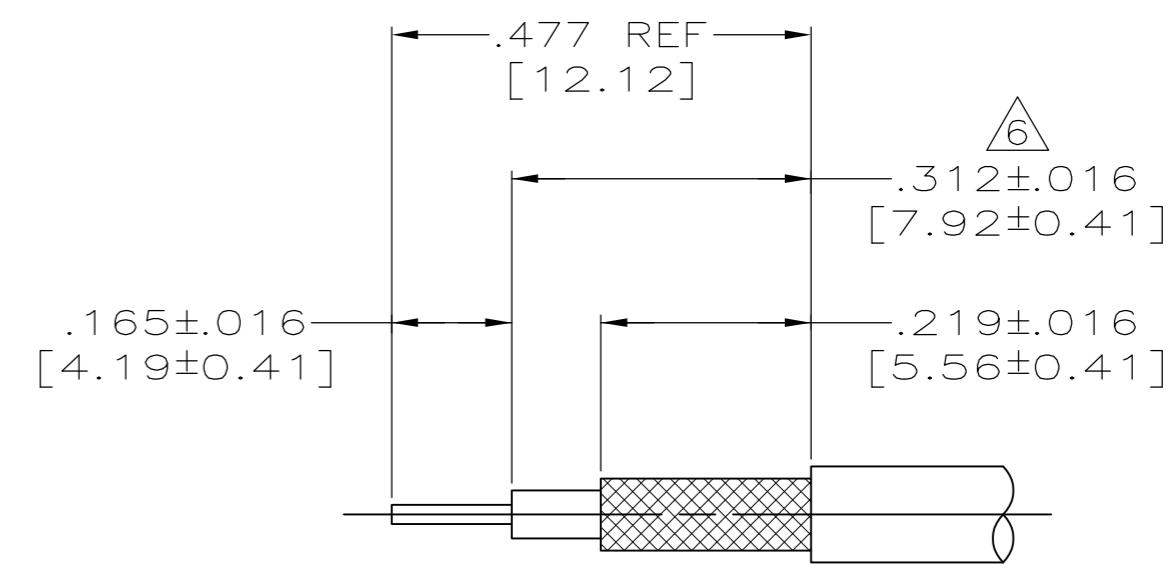
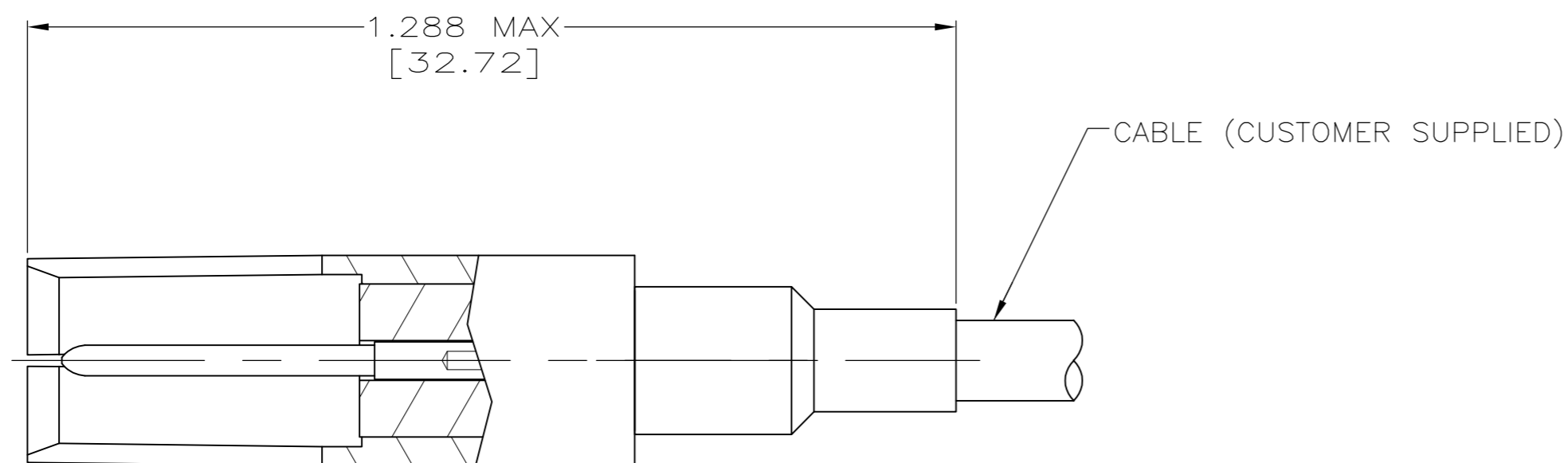

RECOMMENDED STRIP LENGTH
SCALE: N.T.S.

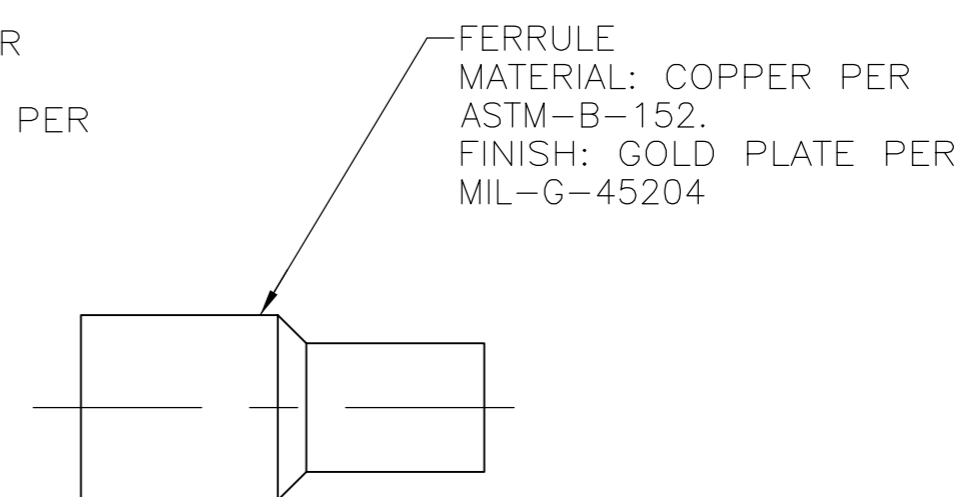
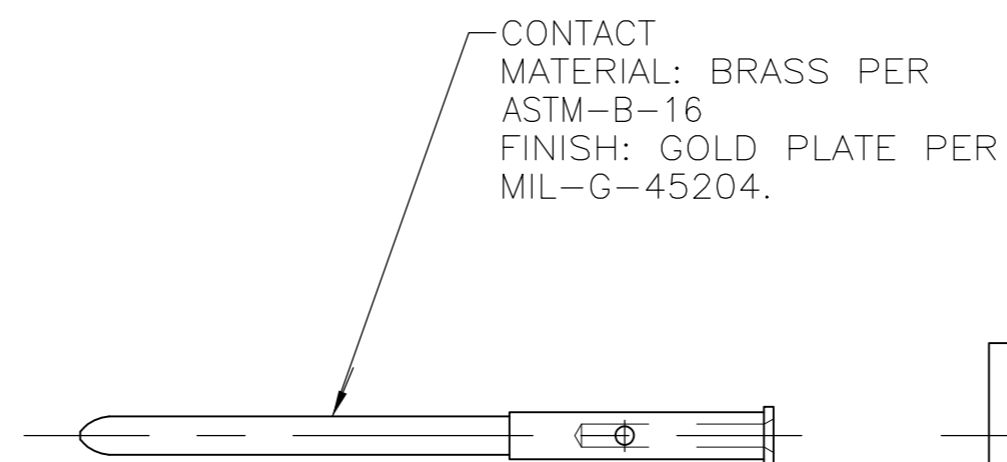
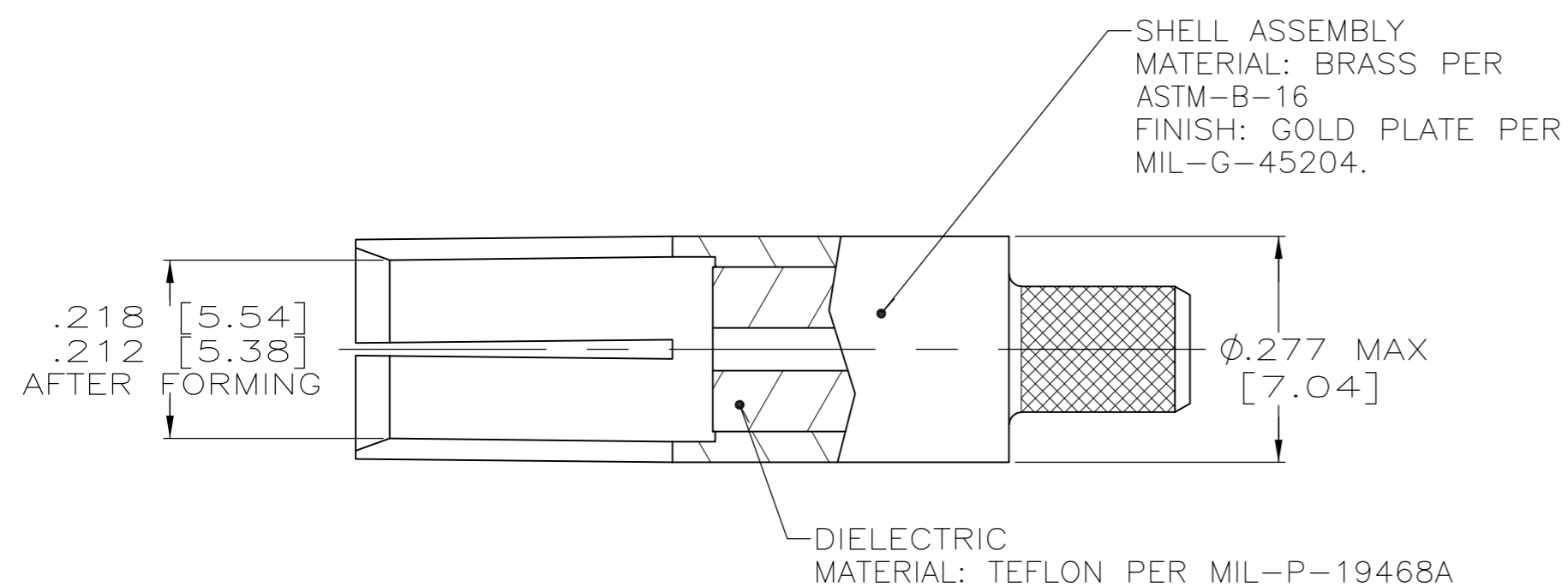

- FOR USE WITH 188A/u & 316/U COAX CABLE.
- FERRULE CRIMPING TOOL: AMP TOOL #220066-1 CRIMP C OR 220066-2 CRIMP C OR 220009-1 CRIMP C.
- CONTACT CRIMPING TOOL: M22520/2-01 OR AMP TOOL NUMBER 1-601966-6, SETTING NUMBER 5. DANIELS POSITIONER PART NO. K345 OR AMP TOOL NO. 1-601966-6.

- SEE I.S.2348.
- DANIELS MANUFACTURING CORP
2266 FRANKLIN ROAD
BLOOMFIELD HILLS, MI 48013

△ OUTER JACKET OF CABLE MUST BE TRIMMED TO ALLOW PROPER INTER-PIN CONTACT LOCATION AFTER FERRULE CRIMP OPERATION.

- PARTS SHIPPED UNASSEMBLED AND CABLE IS SUPPLIED BY CUSTOMER.

225791-9

PART NO.

THIS DRAWING IS A CONTROLLED DOCUMENT.		DWN	C.C.THOMAS	2-1-95	TE Connectivity		
DIMENSIONS: INCHES		CHK	J.DUNBAR	2-2-95			
TOLERANCES UNLESS OTHERWISE SPECIFIED:		APVD	-	-	NAME		
0 PLC ± -		PRODUCT SPEC		CONNECTOR, COAXIAL, RF			
1 PLC ± -		APPLICATION SPEC		SOCKET SIZE 5, ARINC			
2 PLC ± -		WEIGHT		(HEX CRIMP)			
3 PLC ± -		SCALE		SIZE CAGE CODE DRAWING NO RESTRICTED TO			
4 PLC ± -		CUSTOMER DRAWING		A2 00779 C=225791-9			
ANGLES ± -		SHEET		1 of 1			
FINISH SEE CALLOUTS		REV		D			