



Chipsmall Limited consists of a professional team with an average of over 10 year of expertise in the distribution of electronic components. Based in Hongkong, we have already established firm and mutual-benefit business relationships with customers from,Europe,America and south Asia,supplying obsolete and hard-to-find components to meet their specific needs.

With the principle of “Quality Parts,Customers Priority,Honest Operation,and Considerate Service”,our business mainly focus on the distribution of electronic components. Line cards we deal with include Microchip,ALPS,ROHM,Xilinx,Pulse,ON,Everlight and Freescale. Main products comprise IC,Modules,Potentiometer,IC Socket,Relay,Connector.Our parts cover such applications as commercial,industrial, and automotives areas.

We are looking forward to setting up business relationship with you and hope to provide you with the best service and solution. Let us make a better world for our industry!



## Contact us

Tel: +86-755-8981 8866 Fax: +86-755-8427 6832

Email & Skype: info@chipsmall.com Web: www.chipsmall.com

Address: A1208, Overseas Decoration Building, #122 Zhenhua RD., Futian, Shenzhen, China



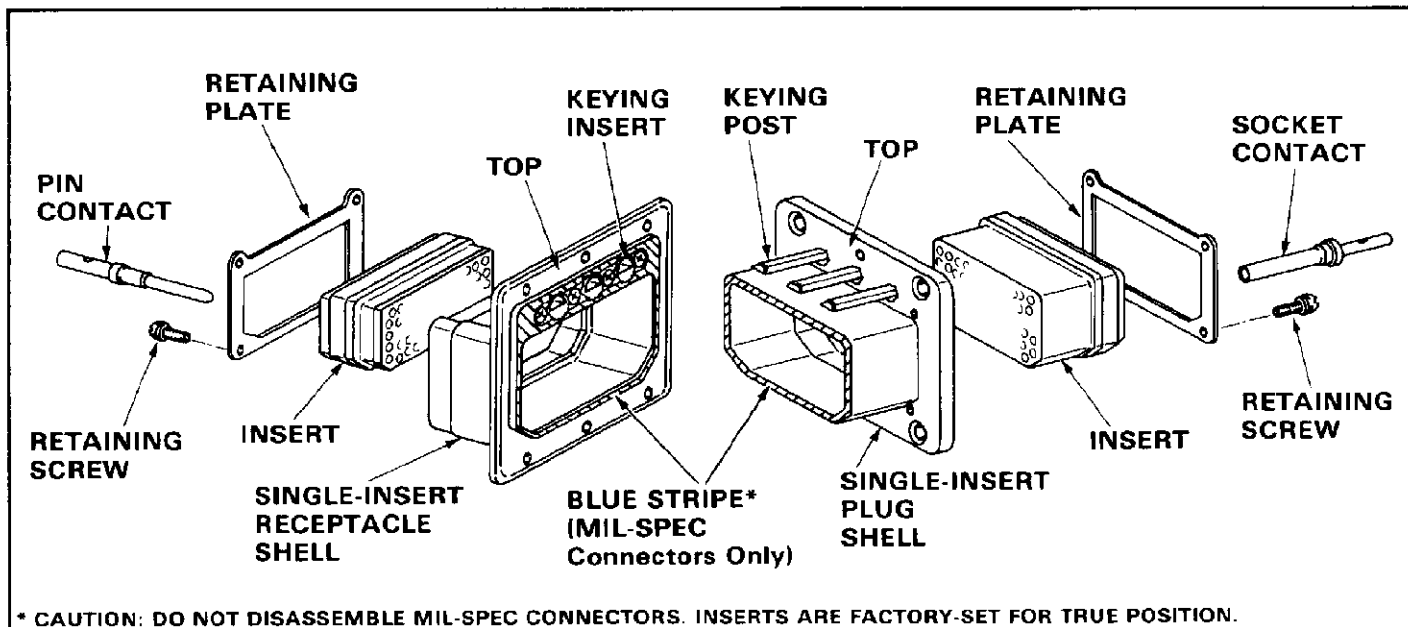

\* CAUTION: DO NOT DISASSEMBLE MIL-SPEC CONNECTORS. INSERTS ARE FACTORY-SET FOR TRUE POSITION.

Fig. 1

**1. INTRODUCTION**

This instruction sheet (IS) covers AMP ARINC 404 rear-release rack-and-panel connectors, Series R, RM, RME, M, MM, and MME. It supplies basic information on connectors, contact part numbers, hand crimping tools, and insertion/extraction tools and the procedures for using them. Further information on tooling and contacts is found on other AMP instruction sheets referenced throughout this sheet.

The AMP connectors are intermateable with other connectors meeting ARINC Specification 404 or MIL-C-81695 and having similar shell size and contact arrangements.

**NOTE** Tooling part numbers beginning with *M* are military-specification part numbers. Other part numbers are AMP part numbers. Often both military and AMP numbers are given. For further cross references of military and AMP tooling numbers, see IS 7516.

**NOTE** All dimensions on this sheet are in inches.

**2. DESCRIPTION**

Figure 1 shows a typical connector. Contacts listed in Figure 2 are crimp, snap-in contacts. Figure 3 lists coaxial contacts, and Figure 4 lists posted and solder-cup contacts.

The connectors are available in six series: R, RM, RME, M, MM, and MME. The series are distinguished as follows:

- R: Unsealed
- RM: Standard, with an interface seal on the pin inserts
- RME: Environmentally sealed
- M: Military-qualified version of Series R
- MM: Military-qualified version of Series RM
- MME: Military-qualified version of Series RME

Copyright 1970, 1971, 1975, 1984, 1986 by AMP Incorporated, Harrisburg, PA. All International Rights Reserved. AMP Incorporated products covered by U.S. and Foreign patents and/or patents pending.

CRIMP, SNAP-IN CONTACTS										
CONT SIZE	TYPE	PART NUMBER		WIRE SIZE	INSUL DIA (Max)	HAND CRIMPING TOOL		POSITIONER		INSERTION/EXTRACTION TOOL
		PIN	SKT			AMP	MIL	AMP	MIL	
22	XVII	205962	205904	30-28	.025	601966-1	M22520/2-01	601966-8	M22520/2-23	91066-1
22	MIL	204873	205103	26-22	.054	601966-1	M22520/2-01	601966-8	M22520/2-23	91066-1
20	XVII	205791	206887	30-26	.071	601966-1	M22520/2-01	601966-5	M22520/2-08	91066-4
20	MIL	204938	205116	24-20	.071	601966-1	M22520/2-01	601966-5	M22520/2-08	91066-4
16	MIL	204978	205117	20-16	.103	601967-1	M22520/1-01	601967-2	M22520/1-02	91066-3
12	MIL	205763	205851	14-12	.190	601967-1	M22520/1-01	601967-1	M22520/1-11	--

Fig. 2

CRIMP, SNAP-IN COAXIAL CONTACTS								
CONTACT SIZE	RG/U CABLE	PART NUMBER		CENTER CONT CRIMPING TOOL		FERRULE CRIMPING TOOL	TOOL IS	EXTRACTION TOOL
		PIN	SOCKET	TOOL	POSITIONER			
1 Straight Exit ↓	.141 Semi-Rigid	225837-1	--	M22520/2-01 601966-1	1-601966-9	220066-1 or -2	IS 2348-2 IS 7516 ↓	91040-7 (IS 7417) ↓
	214	226741-1	225831-1	220015-1	--	220015-1		
	213	--	225831-2	220015-1	--	220015-1		
	142, 142A, 142B	--	225831-3	220045-2	--	220015-2		
	225	--	225831-4	220015-1	--	220015-1		
3 Straight Exit ↓	214	--	225792-1				-- ↓	-- ↓
	213	--	225792-2					
	58C	226053-1	225792-3	M22520/2-01 601966-1	2-601966-4 (Pin) 1-601966-8 (Socket)	220066-1 or -2		
	165	--	225792-4	220015-1	--	220015-1		
	225	--	225792-5	220015-1	--	220015-1		
3 Right-Angle ↓	141, 141A	226053-2	--	220045-2	--	220045-2	-- ↓	-- ↓
	142, 142A, 142B	225803-1	--	220045-2	--	220045-2		
5 Straight ↓	58C	225790-1	225791-1	M22520/2-01 601966-1	1-601966-1	220066-1 or -2	IS 2348 IS 7516 ↓	91074-1 (IS 7542) ↓
	141A	225790-1	225791-1	220066-2	--			
	223	225790-2	225791-2	M22520/2-01 601966-1	1-601966-1			
	142A, 142B	225790-2	225791-2	220066-2	--			
	.141 Semi-Rigid	225790-3	225791-6	220066-2	--			
	174, 188, 316	225790-5	225791-3	M22520/2-01 601966-1	1-601966-1	220066-1 or -2 or 220009-1		
	180, 195	225790-4	225791-8	M22520/2-01 601966-2		220066-1 or -2		
	179, 187	225790-6	225791-4	M22520/2-01 601966-1		220066-1 or -2 or 220009-1		
7 Straight ↓	178, 196	225790-7	225791-5			220020-1	IS 2348-1 IS 7516 ↓	-- ↓
	58C	--	225796-1		1-601966-6	220066-1 or -2		
	141A	--	225796-1	220066-2	--			
	223	--	225796-2	M22520/2-01 601966-1	1-601966-6			
	142A, 142B	--	225796-2	220066-2	--			
7 Right-Angle ↓	174, 188, 316	226052-1	225796-3	M22520/2-01 601966-1	1-601966-6 (Pin) 1-601966-7 (Socket)	220066-1 or -2 or 220009-1	-- ↓	-- ↓
	178, 196	225935-3	225936-4		1-601966-6	220061-1		
	174, 188, 316	225814-1	--		2-601966-6	220066-1 or -2		
9 Straight ↓	58C	225935-1	225936-2		1-601966-6		IS 2348-3 IS 7516 ↓	91074-1 (IS 7542) ↓
	141A	225935-1	225936-2	220066-2	--			
	.141 Semi-Rigid	--	225936-1	220066-2	--			
	174, 188, 316	225935-4	225936-3	M22520-2/01 601966-1	1-601966-1			
	178, 196	225935-3	225936-4	M22520/2-01 601966-1	1-601966-6	220061-1		
	142A, 142B	225935-5	225936-5	220066-2	--	220066-1 or -2		
15 Straight ↓	179B, 187	--	225936-7	M22520/2-01 601966-1	1-601966-6	220066-1 or -2	-- ↓	91066-3 ↓
	188, 316	226782-1	226781-1		2-601966-8	M22520/4-01 601963-2		
	179, 187	226782-2	226781-2					
	178, 196	226782-3	226781-3					

Fig. 3

SOLDER AND WRAP-TYPE CONTACTS					INSERTION/ EXTRACTION TOOL
SIZE	PART NUMBER	TYPE	WIRE-END DESCRIPTION	EXTENSION BEYOND RM SHELL (In.)	
22	205753-2	Pin	.031 Dia Solder Post	.150	91066-1
	205544-1	Socket		.285	
20 ↓	205547-2	Pin		.155	91066-4 ↓ Not Needed
	206210-2*		.025* Wrap-Type Post	.430	
	206210-4*			.685	
	206210-6*			.185	
	206210-8*			.630	
16	205548-2		.062 Dia Solder Post	.155	91066-3 ↓ Not Needed
	206211-2*		Solder Cup	.175	

Fig. 4

\*CAPTIVE-TYPE CONTACTS.

Contacts are held by an insert that is held in a shell by a retaining plate. Shells are available to accept one to

four inserts. Crimp wire contacts and Size 5 and Size 9 coaxial contacts are held in the insert by locking

latches; they can be released and removed from the insert by using an extraction tool from the rear of the connector. Figure 5 lists the inserts available. Note

that other contacts listed in Figure 5 are captive-type contacts and are held within a special two-piece insert; the connector must be taken apart to remove

POSITIONS IN INSERT		106	67		57	45	40	26	8	40C1 (IS 7540)		33C4 (IS 7540)			32C2 (IS 7540)		C8 (IS 7540)		C3 (IS 7541)		C2 (IS 7527)		D8	
NO. OF CONTACTS	Size	22	16	20	20	20	20	16	12	20	5	20	16	5	20	5	9	7	3	1	16	12		
	Quantity	106	3	64	57	45	40	26	8	39	1	25	4	4	30	2	8	2	1	2	4	4		

Fig. 5

															
DARK PORTION INDICATES POSITION OF POST; LIGHT PORTION INDICATES POSITION OF INSERT.															
KEY CODE	PLUG KEYING POST †			KEY CODE	RECEPTACLE KEYING INSERT			KEY CODE	PLUG KEYING POST †			KEY CODE	RECEPTACLE KEYING INSERT		
	L	C	R		L	C	R		L	C	R		L	C	R
00				00				50	2	2	5	50	6	3	3
01	1	1	1	01	4	4	4	51	3	2	5	51	6	3	2
02	2	1	1	02	4	4	3	52	4	2	5	52	6	3	1
03	3	1	1	03	4	4	2	53	5	2	5	53	6	3	6
04	4	1	1	04	4	4	1	54	6	2	5	54	6	3	5
05	5	1	1	05	4	4	6	55	1	2	4	55	1	3	4
06	6	1	1	06	4	4	5	56	2	2	4	56	1	3	3
07	1	1	6	07	5	4	4	57	3	2	4	57	1	3	2
08	2	1	6	08	5	4	3	58	4	2	4	58	1	3	1
09	3	1	6	09	5	4	2	59	5	2	4	59	1	3	6
10	4	1	6	10	5	4	1	60	6	2	4	60	1	3	5
11	5	1	6	11	5	4	6	61	1	2	3	61	2	3	4
12	6	1	6	12	5	4	5	62	2	2	3	62	2	3	3
13	1	1	5	13	6	4	4	63	3	2	3	63	2	3	2
14	2	1	5	14	6	4	3	64	4	2	3	64	2	3	1
15	3	1	5	15	6	4	2	65	5	2	3	65	2	3	6
16	4	1	5	16	6	4	1	66	6	2	3	66	2	3	5
17	5	1	5	17	6	4	6	67	1	2	2	67	3	3	4
18	6	1	5	18	6	4	5	68	2	2	2	68	3	3	3
19	1	1	4	19	1	4	4	69	3	2	2	69	3	3	2
20	2	1	4	20	1	4	3	70	4	2	2	70	3	3	1
21	3	1	4	21	1	4	2	71	5	2	2	71	3	3	6
22	4	1	4	22	1	4	1	72	6	2	2	72	3	3	5
23	5	1	4	23	1	4	6	73	1	3	1	73	4	2	4
24	6	1	4	24	1	4	5	74	2	3	1	74	4	2	3
25	1	1	3	25	2	4	4	75	3	3	1	75	4	2	2
26	2	1	3	26	2	4	3	76	4	3	1	76	4	2	1
27	3	1	3	27	2	4	2	77	5	3	1	77	4	2	6
28	4	1	3	28	2	4	1	78	6	3	1	78	4	2	5
29	5	1	3	29	2	4	6	79	1	3	6	79	5	2	4
30	6	1	3	30	2	4	5	80	2	3	6	80	5	2	3
31	1	1	2	31	3	4	4	81	3	3	6	81	5	2	2
32	2	1	2	32	3	4	3	82	4	3	6	82	5	2	1
33	3	1	2	33	3	4	2	83	5	3	6	83	5	2	6
34	4	1	2	34	3	4	1	84	6	3	6	84	5	2	5
35	5	1	2	35	3	4	6	85	1	3	5	85	6	2	4
36	6	1	2	36	3	4	5	86	2	3	5	86	6	2	3
37	1	2	1	37	4	3	4	87	3	3	5	87	6	2	2
38	2	2	1	38	4	3	3	88	4	3	5	88	6	2	1
39	3	2	1	39	4	3	2	89	5	3	5	89	6	2	6
40	4	2	1	40	4	3	1	90	6	3	5	90	6	2	5
41	5	2	1	41	4	3	6	91	1	3	4	91	1	2	4
42	6	2	1	42	4	3	5	92	2	3	4	92	1	2	3
43	1	2	6	43	5	3	4	93	3	3	4	93	1	2	2
44	2	2	6	44	5	3	3	94	4	3	4	94	1	2	1
45	3	2	6	45	5	3	2	95	5	3	4	95	1	2	6
46	4	2	6	46	5	3	1	96	6	3	4	96	1	2	5
47	5	2	6	47	5	3	6	97	1	3	3	97	2	2	4
48	6	2	6	48	5	3	5	98	2	3	3	98	2	2	3
49	1	2	5	49	6	3	4	99	3	3	3	99	2	2	2

† L = LEFT  
C = CENTER  
R = RIGHT

Fig. 6



or add one of this type of contact. No insertion or extraction tooling is needed.

For environmental sealing, plugs are used to seal unused insert cavities. Using an unwired contact in the cavity before inserting the sealing plug ensures a good seal. To allow the plug to be removed, it should stick out the back of the cavity 1/32 in., minimum.

Each connector is keyed by three keying posts in the plug connector and three keying inserts in the receptacle connector. The hexagonal shape of the keys allows each key to be installed in one of six positions. There are 100 standard keying configurations (including no keying). Figure 6 shows the keying combinations and the keying code used for each combination. (When a connector is ordered with keying parts, but no keying code, the connector is shipped keyed to 01. The keying code is not marked on the connector or on the package.) A holding nut and lockwasher on the back side of the plug secures each keying post. Four retaining screws hold the keying inserts in the receptacle.

Connectors are designed to receive exposed pin contacts in the receptacle and buried socket contacts in the plug. The exception is the 106-position connector, which has buried pin contacts in the plug and exposed socket contacts in the receptacle.

Since many variations in standard connector configurations are available, use caution during assembly. Consult AMP about modifications and special configurations.

### 3. KEYING (Figure 7)

The following is the procedure for installing the keying posts and inserts. Use Figure 6 to select the keying code required.

1. Place the plug on a suitable work surface with the top side up. The top is so labelled.
2. Position the keying posts according to the correct plug keying code in Figure 6.

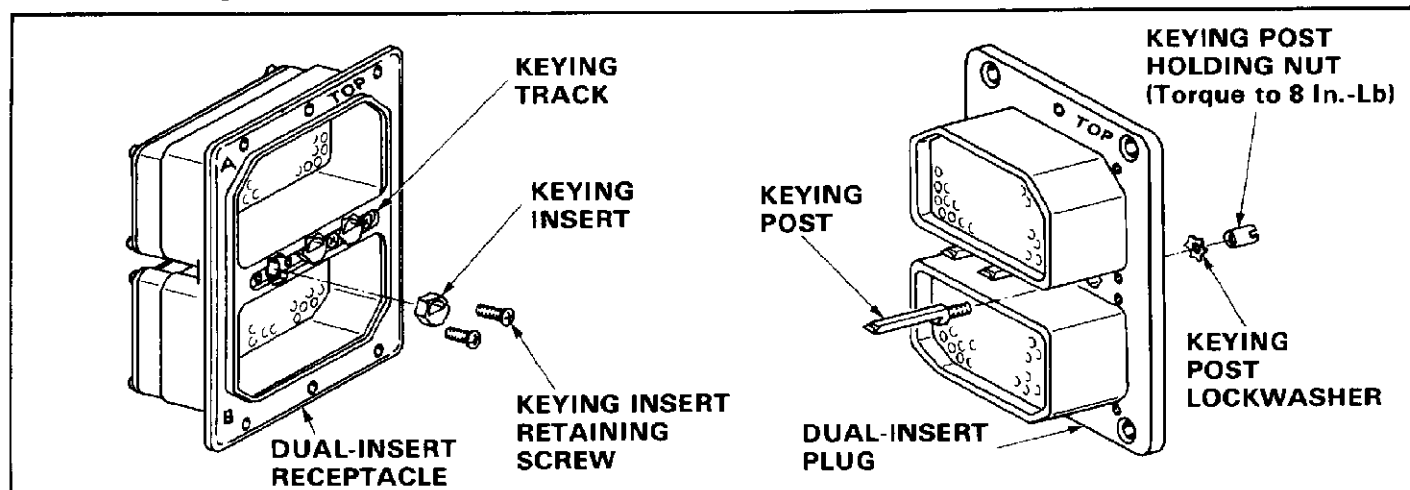

Fig. 7

3. Secure each post with the lockwashers and holding nuts. Torque the nuts to 8 in.-lb.
4. Place the receptacle on the work surface with the top side up. The top is so labelled.
5. Position the keying inserts according to the correct receptacle keying code in Figure 6.
6. Install the retaining screws, and tighten each screw a little at a time to ensure that each insert seats properly.

### 4. PANEL CUTOUTS (Figure 8)

The connectors are designed for rack-and-panel mounting. Normally, the plug is front-mounted to the rack, and the receptacle is back-mounted to the panel. Panel thickness should not exceed 1/8 in. Figure 8 shows the recommended cutout dimensions.

#### NOTE

*If a connector which uses posted contacts is to be soldered to a printed circuit board, the board must be designed to allow access to the screws in the retaining plate. If replacement of a contact becomes necessary, the connector must be taken apart, and this requires access to the retaining-plate screws.*

### 5. CONTACT CRIMPING

Pin and socket contacts are available in loose-piece form for hand crimping and in tape-mounted form for machine crimping. The following tooling is recommended for crimping the contacts listed in Figure 2:

- Hand tools: 601966-1 for Sizes 20 and 22; Hand Tool 601967-1 for Sizes 12 and 16. See IS 7516 for instructions on using these tools.
- Machine: AMP-TAPETRONIC ★ 4/8 Indent Stripper Crimper 599406-[ ]. See AMP Customer Manual 5253 for information on the machine.

Coaxial contacts are available in loose-piece form only. See Figure 3 for recommended hand tools for

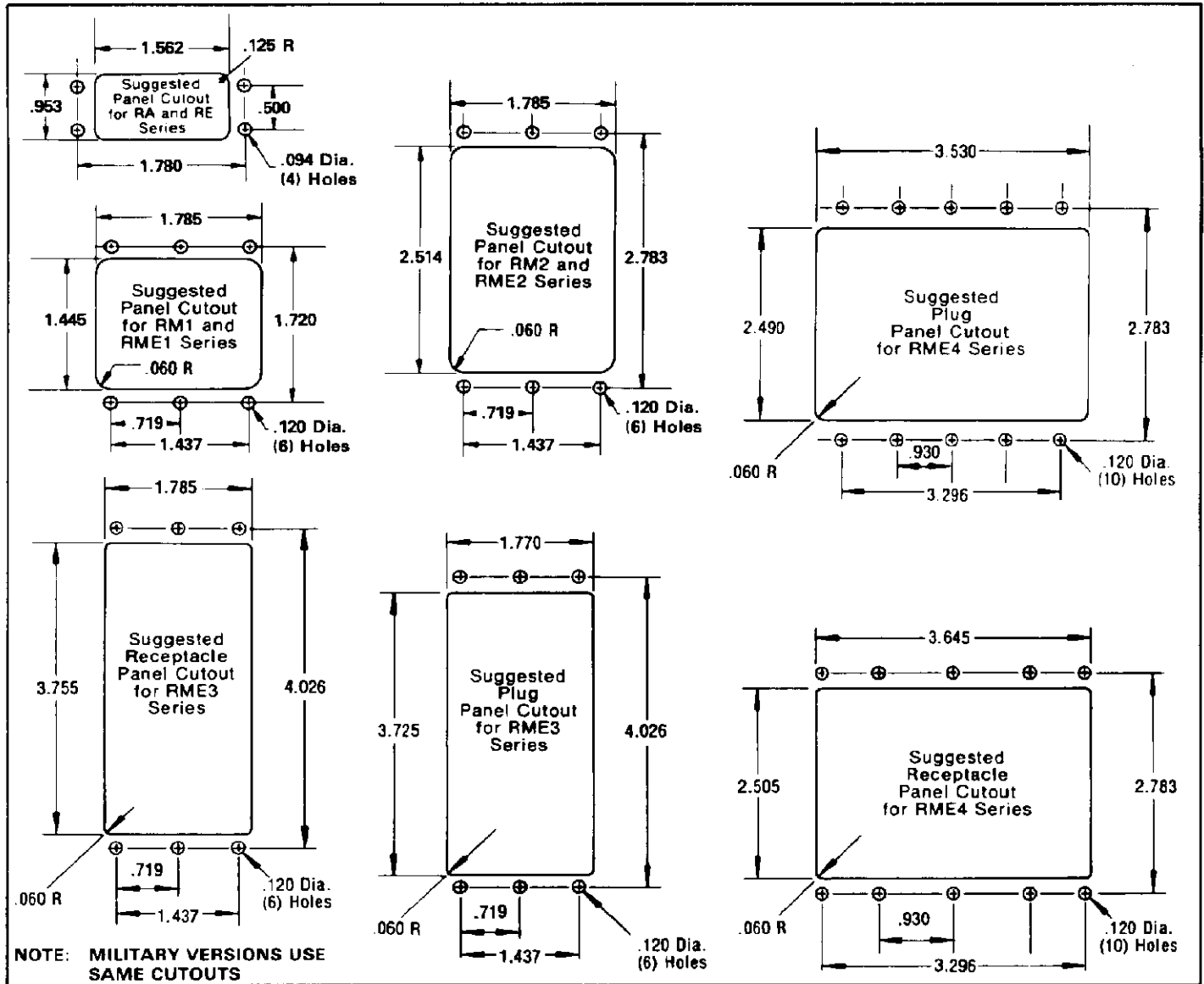

Fig. 8

crimping the center contact and ferrule. For information on preparing the cable and crimping the contacts, see the instructions supplied with the tool and contacts.

**6. INSERTION AND EXTRACTION OF CONTACTS**

AMP Insertion/Extraction Tools 91066-[ ] are designed to insert and extract Size 22, 20, and 16 contacts. The white end of the tool contains the extraction tip. The other end, which is color-coded to contact size, contains the insertion tip. See Figure 9.

Size 5 and Size 9 coaxial contacts are extracted with Extraction Tool 91074-1. These contacts are easily inserted by hand.

Insertion or extraction of Size 3 and Size 7 coaxial contacts requires the connector to be taken apart. See IS 7541 for the procedure. No tooling is needed

for Size 1 coaxial contacts.

Some posted contacts require that the connector be taken apart.

**A. Inserting Size 22, 20, and 16 Contacts (Figure 9)**

1. Place the wire over the wire slot of the insertion tip and hold it there with your thumb.
2. While applying light pressure on the wire, slide your thumb toward the tip of the tool. The tip will spread to allow the wire to enter.
3. Position the tool tip against the contact shoulder as shown in Figure 9.
4. Press the wire against the tool handle to hold the contact in position.
5. Reposition tool handle between thumb and finger tips.

**WARNING**

*It is important that you hold the tool handle between your thumb and finger tips to*

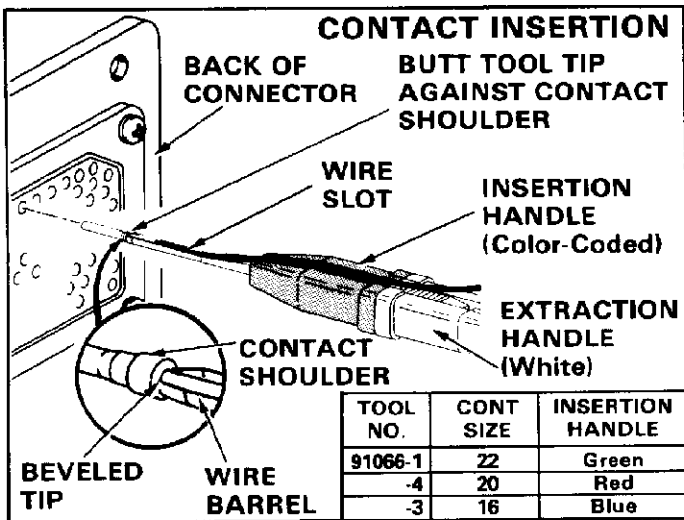

Fig. 9

prevent the possibility of injury. Do NOT hold tool with unused tip (end) toward or against palm of your hand.

6. Insert contact *straight* into the cavity until it bottoms.
7. Remove the tool. Pull back lightly on the wire to ensure that the contact is locked in the cavity.

#### B. Extracting Size 22, 20, and 16 Contacts (Figure 10)

1. Place the wire over the wire slot of the extraction tip and hold it here with your thumb.
2. Apply light pressure on the wire and slide your thumb toward the tip of the tool. The tip will spread to allow the wire to enter.
3. Reposition tool handle between thumb and finger tips.

#### WARNING

*It is important that you hold the tool handle between your thumb and finger tips to prevent the possibility of injury. Do NOT hold tool with unused tip (end) toward or against palm of your hand.*

4. Insert the tool *straight* into the cavity until the tip bottoms.
5. Hold the wire against the tool handle, and

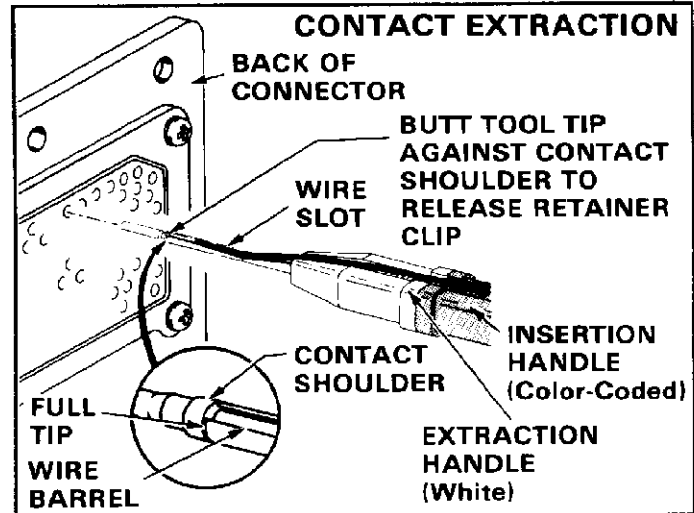

Fig. 10

pull the tool and wire straight out the back of the cavity.

#### C. Extracting Size 5 and 9 Contacts (Figure 11)

1. If the contact to be removed is sealed with a sealing boot, slide the boot back over the cable at least 3 1/4 in. so that it does not interfere with the extraction. Do not cut or otherwise damage the boot.
2. Place the cable over the V-notch of the tool handle; then, press the cable into the notch. The handle will spread open to allow the cable to enter. Make sure the cable fully seats in the handle and tip.
3. Insert the tool tip into the contact cavity until it bottoms.
4. Maintain a slight forward pressure on the tool handle as you pull back on the cable to release the contact.
5. Pull the cable, contact, and tool out the back of the connector.
6. Remove the cable from the tool.

#### D. Inserting or Extracting Size 3 and 7 Coaxial Contacts

See IS 7541 for proper procedures.

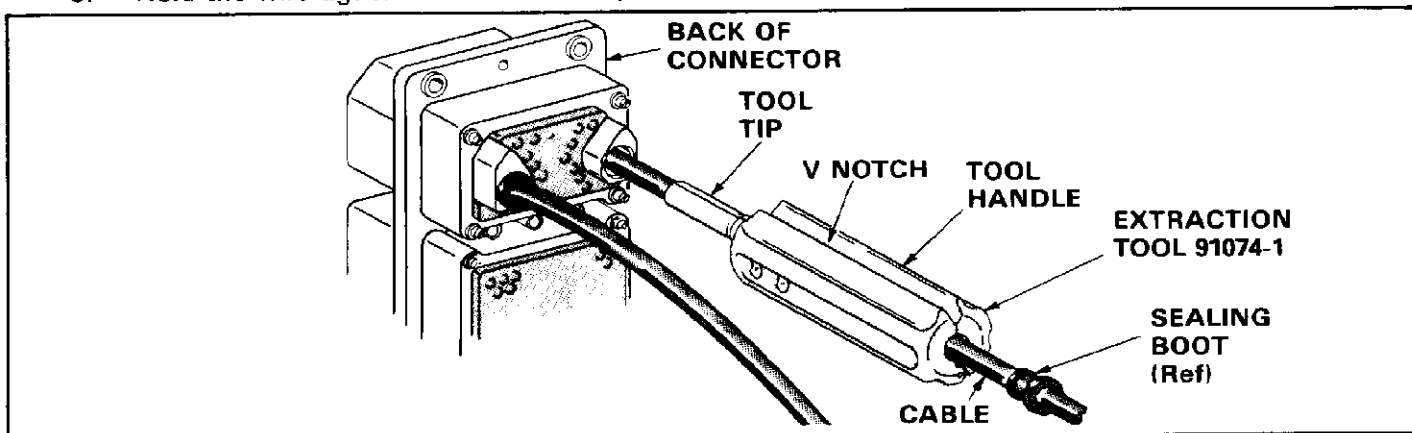

Fig. 11