



Chipsmall Limited consists of a professional team with an average of over 10 year of expertise in the distribution of electronic components. Based in Hongkong, we have already established firm and mutual-benefit business relationships with customers from,Europe,America and south Asia,supplying obsolete and hard-to-find components to meet their specific needs.

With the principle of “Quality Parts,Customers Priority,Honest Operation,and Considerate Service”,our business mainly focus on the distribution of electronic components. Line cards we deal with include Microchip,ALPS,ROHM,Xilinx,Pulse,ON,Everlight and Freescale. Main products comprise IC,Modules,Potentiometer,IC Socket,Relay,Connector.Our parts cover such applications as commercial,industrial, and automotives areas.

We are looking forward to setting up business relationship with you and hope to provide you with the best service and solution. Let us make a better world for our industry!



Contact us

Tel: +86-755-8981 8866 Fax: +86-755-8427 6832

Email & Skype: info@chipsmall.com Web: www.chipsmall.com

Address: A1208, Overseas Decoration Building, #122 Zhenhua RD., Futian, Shenzhen, China



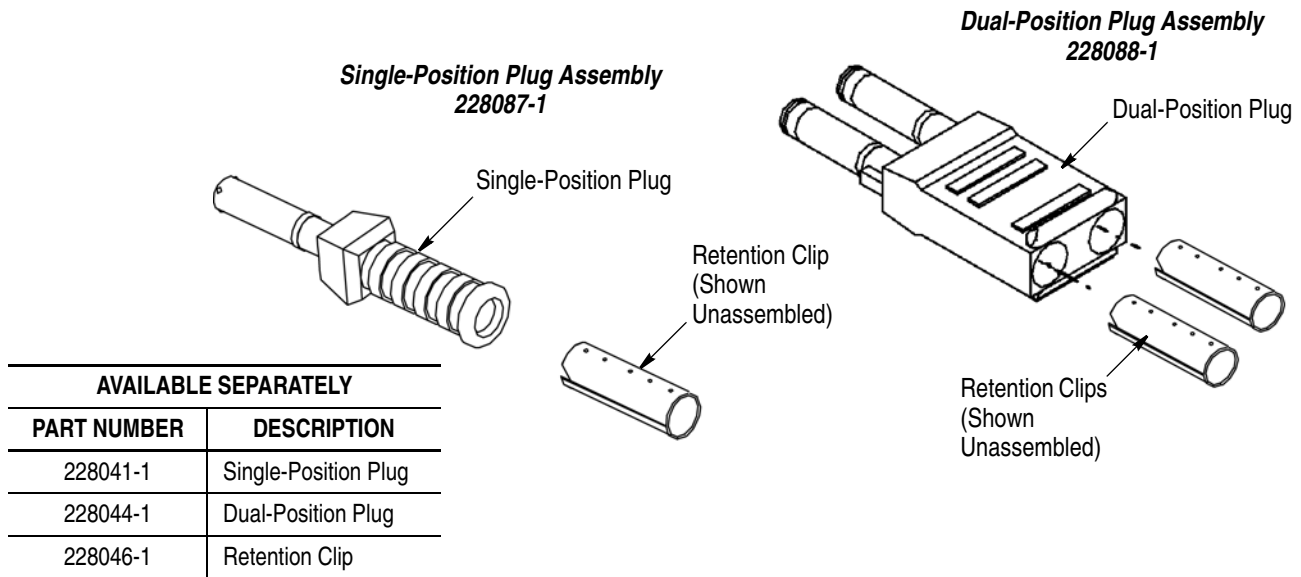
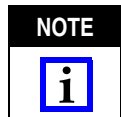

Figure 1

1. INTRODUCTION

This instruction sheet covers the termination procedure for OPTIMATE DNP fiber optic plug assemblies shown in Figure 1. The plug assemblies are designed to be used with 1000- μ m plastic fibers.



Dimensions in this instruction sheet are in metric units [with U.S. customary units in brackets]. Figures are not drawn to scale.

The following tools are recommended:

- Hot Knife 228085-1 or equivalent
- Cable Stripper 501198-1
- Cutting Fixture 228837-1
- Techni-Tool, Inc. Long Nose Pliers 461PL621

Reasons for reissue of this instruction sheet are provided in Section 5, REVISION SUMMARY.

2. DESCRIPTION (Figure 1)

The plug assembly is available in single-position and dual-position with a pre-assembled retention clip. The retention clip, barbed both inside and out, engages the jacket of the fiber and the inside of the plug assembly. The plug assembly can be applied to fibers without the need for polishing or the use of epoxy.

Fiber-to-fiber connections are made with single-position bulkhead receptacles that can be disconnected. Fibers can also be mated to active devices (sources

and detectors) mounted in an active device mount (ADM). Refer to Instruction Sheet 408-9234 for information concerning the receptacles and ADMs.

3. TERMINATION PROCEDURE

The following procedure is for terminating a fiber to a single-position plug assembly. The same procedure is used for the dual-position plug assembly, except that the procedure is repeated for the second plug assembly.

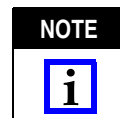

Although it is not required to use a hot knife to trim the fiber, using a hot knife will improve the optical and mechanical characteristics of the termination.

1. Using the insulation stripping tool, strip the jacket from the fiber to the dimension given in Figure 2, Detail A. Make sure the tool is set for cable size 20 AWG or 1000- μ m fiber.



Do not nick or cut the fiber. If the tool does not have the referenced setting, use a small piece of fiber as a guide for setting the tool.

2. Using the insertion tool, push the stripped cable into the plug until the cable bottoms and excess fiber extends out the nose of the plug. See Figure 2, Detail B.
3. Pull back slightly on the cable to ensure that the barbs on the retention clip engage the jacket and plug.

Techni-Tool is a trademark.

Single-Position Cable Plug Assembly Shown

Detail A

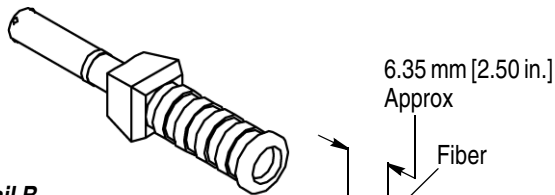

Detail B

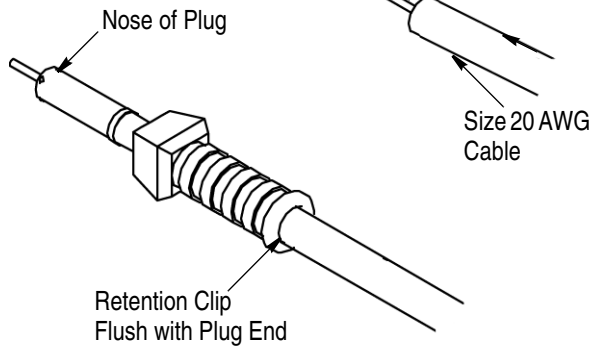

Figure 2

4. Slide the plug into the cutting tool as shown in Figure 3, Detail A.



In the next several steps, the fiber is trimmed and riveted with the hot knife. BE SURE TO KEEP FINGERS AWAY FROM THE CUTTING TOOL FIXTURE. Allow the fixture to cool before removing it.

5. Place the flat side of the hot knife blade in the lower area (melting area) of the fixture. Press down on the blade to melt the remaining fiber flush with the end of the plug. The fiber should form a small rivet in the plug to aid retention. See Figure 3, Detail B.

6. Allow the fixture to cool, and then remove it.

7. Inspect the plug for proper termination. The end of the fiber should form a rivet flush with the end of the plug.

8. The plug is now ready to be mated with the receptacle or ADM. Push the plug, nose first, into the receptacle or ADM until it latches tightly.

4. REPLACEMENT AND REPAIR

DO NOT use defective or damaged product. DO NOT re-use the plug by removing the fiber or cable.

Order kits through your Representative, or call 1-800-526-5142, or send a facsimile of your purchase order to 717-986-7605, or write to:

CUSTOMER SERVICE (038-035)
 TYCO ELECTRONICS CORPORATION
 PO BOX 3608
 HARRISBURG PA 17105-3608

Detail A

Slice Off Excess Fiber

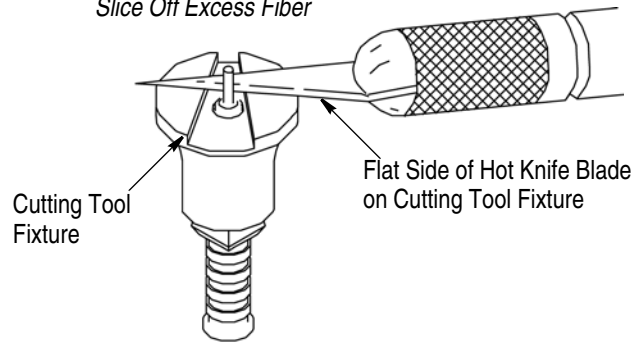

Detail B

Melt Fiber End Into Rivet

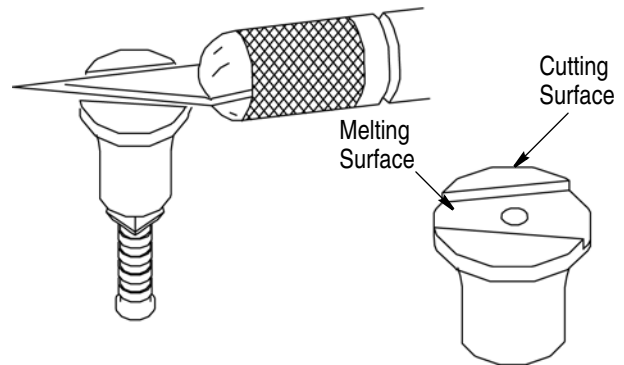

Figure 3

5. REVISION SUMMARY

Revisions to this instruction sheet include:

- Changed company name and logo
- Updated instruction sheet to corporate requirements