



Chipsmall Limited consists of a professional team with an average of over 10 year of expertise in the distribution of electronic components. Based in Hongkong, we have already established firm and mutual-benefit business relationships with customers from,Europe,America and south Asia,supplying obsolete and hard-to-find components to meet their specific needs.

With the principle of “Quality Parts,Customers Priority,Honest Operation,and Considerate Service”,our business mainly focus on the distribution of electronic components. Line cards we deal with include Microchip,ALPS,ROHM,Xilinx,Pulse,ON,Everlight and Freescale. Main products comprise IC,Modules,Potentiometer,IC Socket,Relay,Connector.Our parts cover such applications as commercial,industrial, and automotives areas.

We are looking forward to setting up business relationship with you and hope to provide you with the best service and solution. Let us make a better world for our industry!



Contact us

Tel: +86-755-8981 8866 Fax: +86-755-8427 6832

Email & Skype: info@chipsmall.com Web: www.chipsmall.com

Address: A1208, Overseas Decoration Building, #122 Zhenhua RD., Futian, Shenzhen, China



NV1600 Flashtec NVRAM Drive Family

NV1616, NV1608, NV1604

The Microsemi Flashtec NVRAM Drive family provides a PCI Express NVRAM solution based on the most advanced NVMe controller on the market. This family provides a new level of performance to the memory/storage hierarchy, ushering storage system OEMs, cloud applications, and service providers for the era of storage class memory.

Establishes New Storage Tier with Superior Performance

- Non-volatile DRAM-like performance, NAND persistence
- Over 10 million IOPS
- Sub-microsecond latency

Faster Time-to-Market and Lower Cost of Ownership

- Industry-standard interfaces
- Application-friendly for ease of integration
- Zero maintenance green backup
- “Enterprise Class” for mission-critical data center
- Uncompromising quality and reliability
- Unlimited endurance NVRAM
- Small form factor for high-density rack solutions

Included

- Add-in card
- SCM-F100/F70/F35 module and cable

Cloud-Scale Performance and Availability

While SSD solutions continue to replace traditional HDDs in the performance tier of the storage hierarchy, there remains a significant performance gap between the memory tiers and the storage tiers in terms of latency, endurance, and high availability. As application demands continue to increase at an ever growing pace to keep up with the growth rate of cloud services, relying on volatile memory to achieve desired performance leaves applications vulnerable to data loss in the event of a system failure.

There is a need for a new tier of memory that provides mission-critical applications the necessary safety net for their data while keeping pace with the application requirements for performance without compromising data protection, reliability, and availability.

Flashtec NVRAM Drive products serve exactly that need, and with >10 M IOPS and up to 16 GB of memory per card, the product family can address the needs of the most demanding applications.

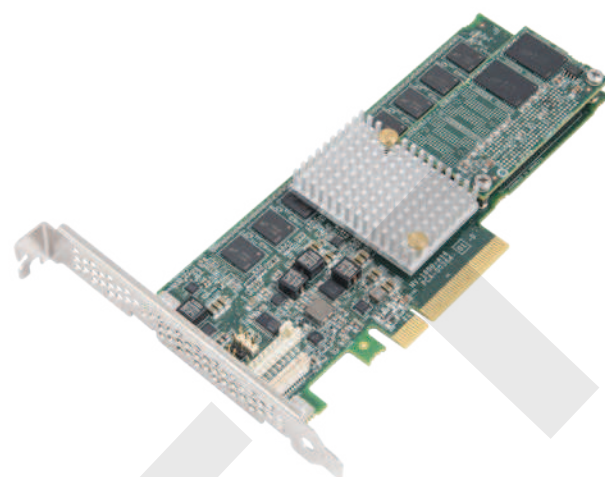

Applications

- Write cache for low-latency response time
- 64-bit addressable persistent metadata memory region
- Persistent shared memory for scale-out clustered systems
- High performance journaling or write ahead logging
- Persistent cache for fast cache rebuild
- Performance tier de-staging to sequential-access capacity tier

Benefits

- **Unlimited Endurance:** Unlike SSDs, DRAM has practically unlimited endurance, and with up to 16 GB of non-volatile DRAM memory, NV1600 drives can fit very demanding workloads as well.
- **High Performance I/O:** 1 million IOPS in NVMe block mode (4 KB); over 10 million IOPS in direct memory mode.
- **Power Failure Protection:** Flash-based backup unit protects DRAM content in the event of a power failure.
- **Higher Availability:** A fast backup and recovery cycle ensures that mission critical applications will have a shorter recovery time across power failure events.
- **Lower Total Cost of Ownership:** Eliminating the UPS or BBU frees up rack space and reduces support and maintenance cost without compromising critical system data across power failures.

NV1600 Flashtec NVRAM Drive Family

NV1616, NV1608, NV1604

General Features

Host Interface	x8 lane
PCI Express	3.0
Form Factor	Low profile MD2 PCIe add-in card
Access Modes	Block mode and direct memory mode
Memory Capacity	4/8/16 GB configurations
Backup Store	Flash module
Data Retention Offline	3 months
No. of Backup Images	Two backup image banks
Backup Power Supply	Tethered super capacitor module
Auxiliary Power	Optional 5 V input
Restore Time	< 15 sec
Backup Time	< 20 sec
Backup Cycles	> 3000
Management Interface	NVMe
Monitoring and Alerts	Yes

Hardware Support

Driver Support Industry	Supported NVMe drivers
Application Support	NV-lib for application integration

Data Protection & Security

Authentication	Optional host authentication sequence
-----------------------	---------------------------------------

Mechanical & Environmental

Form Factor	MD2 low profile PCIe card
Operating Temperature	0 °C to 50 °C @ 200 LFM
Power Consumption	<20 W typical; 5 W idle

Reliability

Maintenance	No maintenance required
Operational Lifetime	5 years

Compliance & Certification

NVMe.org	NVMe 1.0 compatible
PCIe SIG	Certified

Ordering Information

Model	Description	PN
NV1616	16 GB NVRAM PCIe drive and SCM-F100 bulk	2286100-R
NV1608	8 GB NVRAM PCIe drive and SCM-F70 bulk	2285500-R
NV1604	4 GB NVRAM PCIe drive and SCM-F35 bulk	2285400-R

Block Mode Access

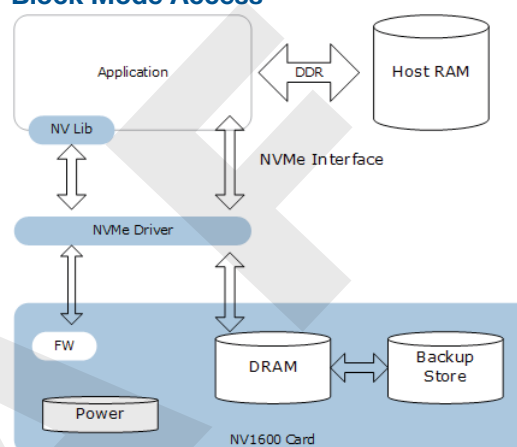

Direct Memory Access

