



Chipsmall Limited consists of a professional team with an average of over 10 year of expertise in the distribution of electronic components. Based in Hongkong, we have already established firm and mutual-benefit business relationships with customers from,Europe,America and south Asia,supplying obsolete and hard-to-find components to meet their specific needs.

With the principle of “Quality Parts,Customers Priority,Honest Operation,and Considerate Service”,our business mainly focus on the distribution of electronic components. Line cards we deal with include Microchip,ALPS,ROHM,Xilinx,Pulse,ON,Everlight and Freescale. Main products comprise IC,Modules,Potentiometer,IC Socket,Relay,Connector.Our parts cover such applications as commercial,industrial, and automotives areas.

We are looking forward to setting up business relationship with you and hope to provide you with the best service and solution. Let us make a better world for our industry!



## Contact us

Tel: +86-755-8981 8866 Fax: +86-755-8427 6832

Email & Skype: info@chipsmall.com Web: www.chipsmall.com

Address: A1208, Overseas Decoration Building, #122 Zhenhua RD., Futian, Shenzhen, China



THIS DRAWING IS UNPUBLISHED. RELEASED FOR PUBLICATION - N/A .  
 © COPYRIGHT N/A By - ALL RIGHTS RESERVED.

LOC	DIST	REVISIONS					
DF	X0	P	LTR	DESCRIPTION	DATE	DWN	APVD
		P1		REVISED PER ECO-11-005030	11MAR11	RK	HMR

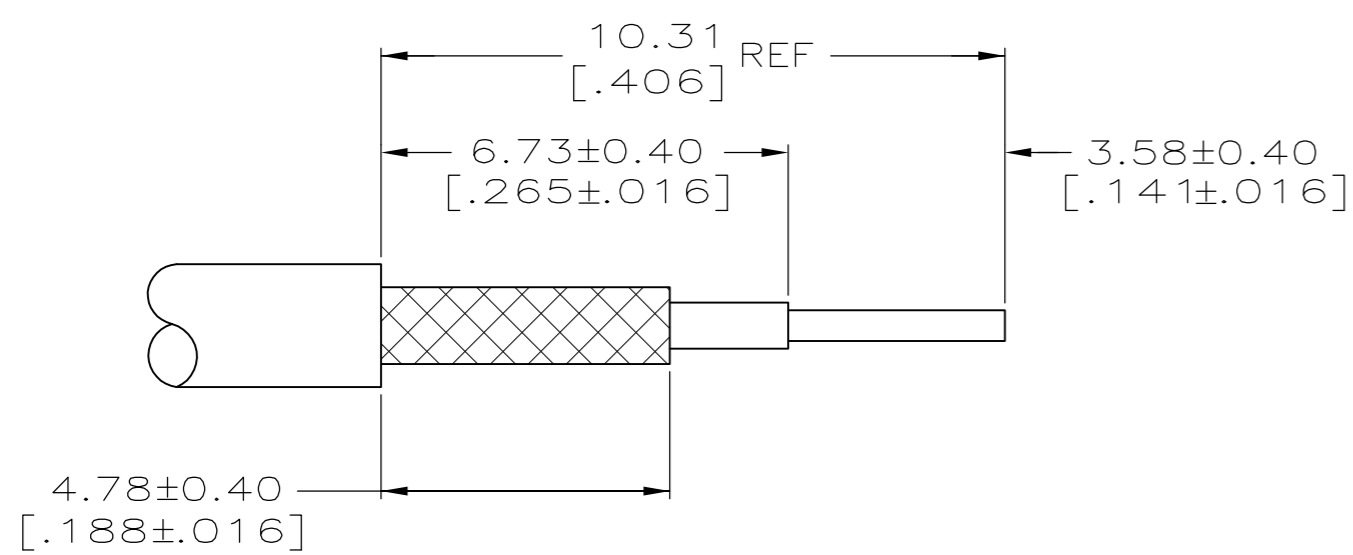
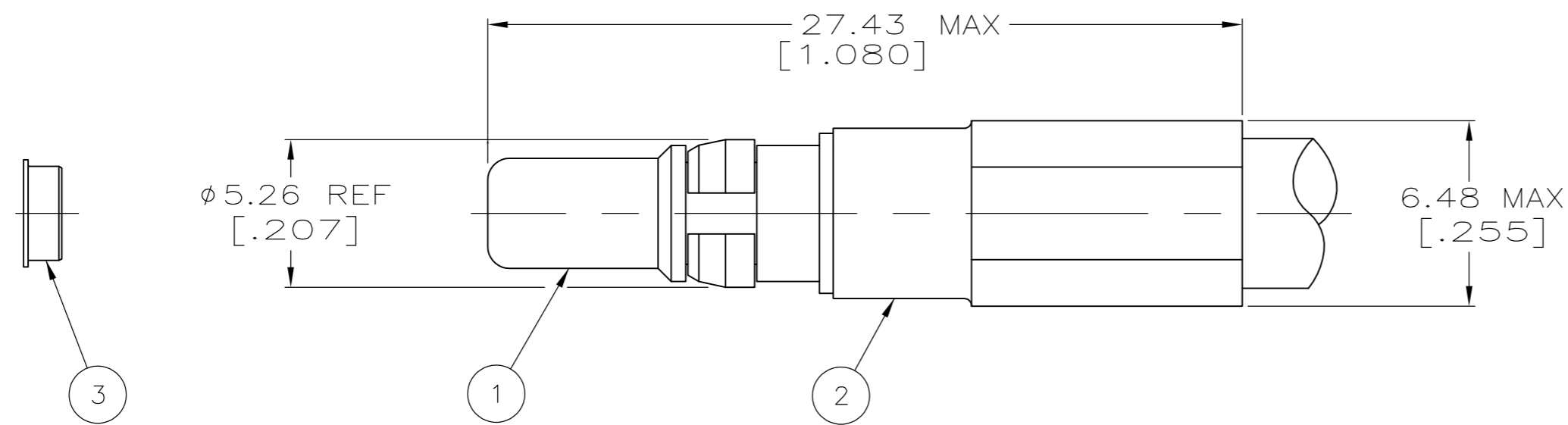
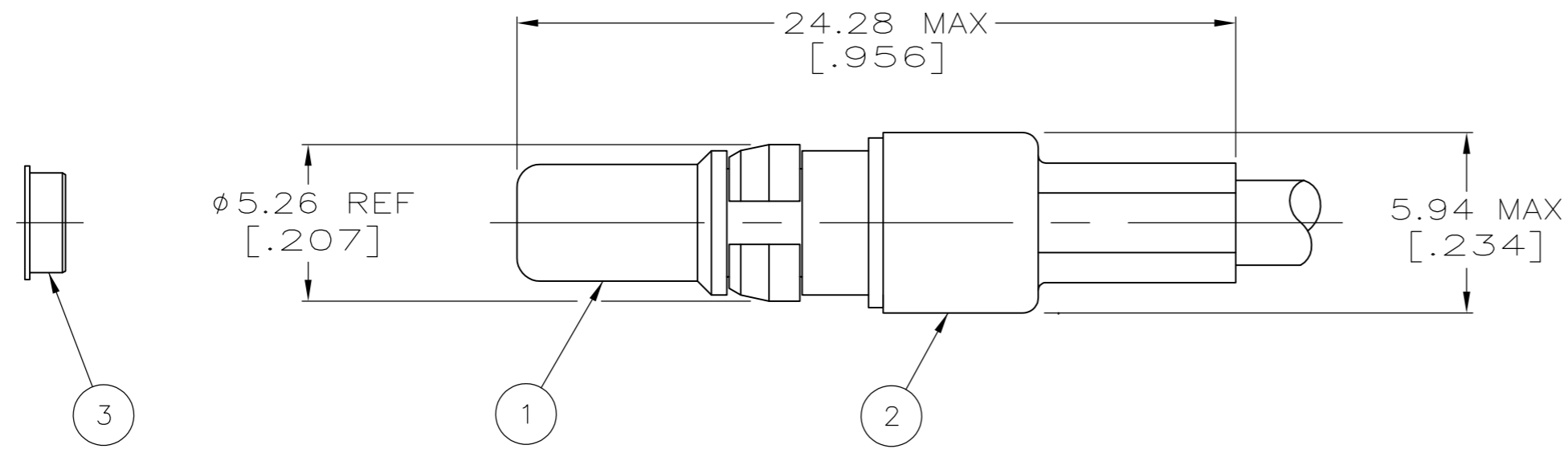

- 1. FOR USE WITH: RG-142/U, 142A/U, 142B/U, 58A/U & 400/U, BELDIN 9246 CABLE.
- 2. SEE I.S. 6755.
- 3. USE HAND TOOL: 69710-2. PNEUMATIC TOOL: 69365-8.
- 3. EXTRACTION TOOL: 58095-1.
- 4. ITEM #3 IS USED TO STABILIZE THE CRIMPED CONNECTOR IN THE HOUSING CAVITY, OTHERWISE DISCARD.
- 5. IMPEDANCE: 33 OHMS APPROXIMATELY.

59993-1	RG-178/U,178A/U & 178B/U	228616-1	5-221824-3	5-228624-3	X	5-228618-5
58212-1	△	228616-1	9-221357-0	221354-1	Y	5-228618-4
59993-1	RG-179/U,179A/U,179B/U,187/U & 187A/U	228616-1	9-228603-0	5-228624-2	X	5-228618-2
59993-1	RG-174/U,188/U & 316/U	228616-1	9-228603-0	5-228624-1	X	5-228618-1
59993-1	RG-174/U,188A/U & 316/U	228616-1	228603-3	228624-4	X	228618-6
59993-1	RG-178/U,178A/U & 178B/U	228616-1	221824-3	228624-3	X	228618-5
58212-1	△	228616-1	221357-3	221354-1	Y	228618-4
59993-1	RG-188 TYPE DOUBLE BRAID	228616-1	221205-3	228624-1	X	228618-3
59993-1	RG-179/U,179A/U,179B/U,187/U & 187A/U	228616-1	228603-3	228624-2	X	228618-2
59993-1	RG-174/U,188/U & 316/U	228616-1	228603-3	228624-1	X	228618-1
VIEW	USE WITH CABLE	3 ALIGNMENT RING QTY=1	2 FERRULE QTY=1	1 PIN ASSY QTY=1	VIEW	PART NUMBER

THIS DRAWING IS A CONTROLLED DOCUMENT.

DWN	B. WERNER	26-AUG-91
CHK	D. DOYE	26-AUG-91
APVD	D. DOYE	26-AUG-91

**TE** TE Connectivity

NAME: PIN, STRAIGHT, SIZE 8

SIZE	A2	CAGE CODE	00779	DRAWING NO	C=228618	RESTRICTED TO	-
WEIGHT	-	SCALE	5:1	SHEET	1 of 1	REV	P1

CUSTOMER DRAWING