



Chipsmall Limited consists of a professional team with an average of over 10 year of expertise in the distribution of electronic components. Based in Hongkong, we have already established firm and mutual-benefit business relationships with customers from,Europe,America and south Asia,supplying obsolete and hard-to-find components to meet their specific needs.

With the principle of “Quality Parts,Customers Priority,Honest Operation,and Considerate Service”,our business mainly focus on the distribution of electronic components. Line cards we deal with include Microchip,ALPS,ROHM,Xilinx,Pulse,ON,Everlight and Freescale. Main products comprise IC,Modules,Potentiometer,IC Socket,Relay,Connector.Our parts cover such applications as commercial,industrial, and automotives areas.

We are looking forward to setting up business relationship with you and hope to provide you with the best service and solution. Let us make a better world for our industry!



Contact us

Tel: +86-755-8981 8866 Fax: +86-755-8427 6832

Email & Skype: info@chipsmall.com Web: www.chipsmall.com

Address: A1208, Overseas Decoration Building, #122 Zhenhua RD., Futian, Shenzhen, China



THIS DRAWING IS UNPUBLISHED. RELEASED FOR PUBLICATION 20
 © COPYRIGHT 20 BY - ALL RIGHTS RESERVED.

REVISIONS				
P	LTR	DESCRIPTION	DATE	APVD
	A	RELEASED PER ECO-15-010501	17JUL2015	JM RB
	A1	REV PER ECO-16-007279	12MAY2016	JM RB
	A2	REV PER ECO-16-013256	08SEP2016	JM RB

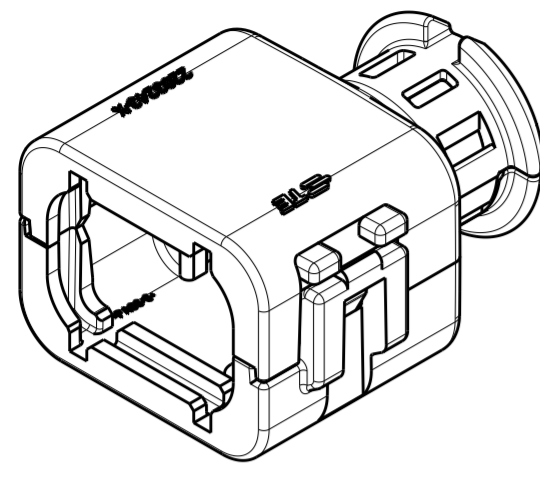

2292860-1
ASSEMBLED ISOMETRIC VIEW SHOWN

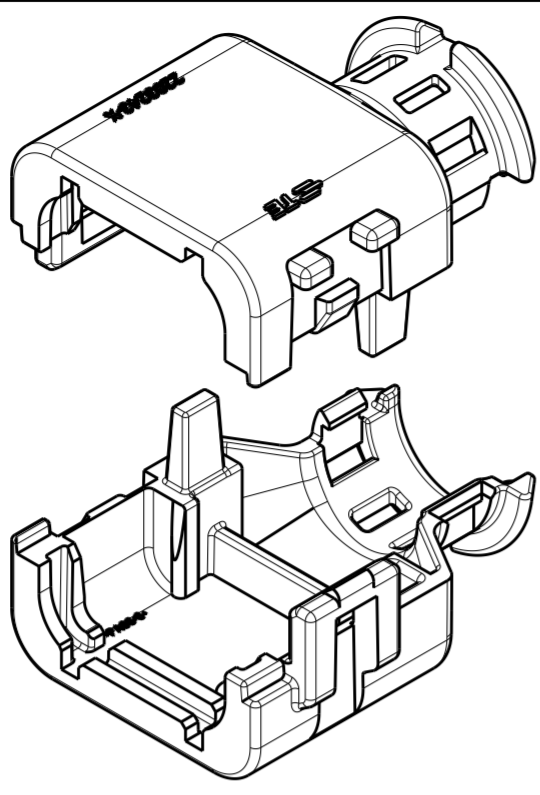

2292860-1
EXPLODED ISOMETRIC VIEW SHOWN

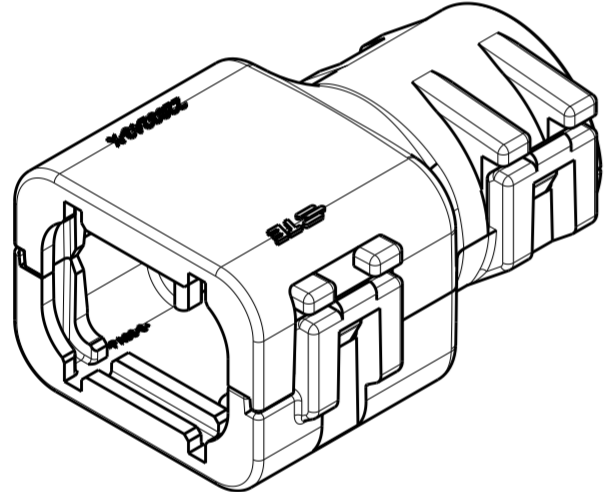

2292860-2
ASSEMBLED ISOMETRIC VIEW SHOWN

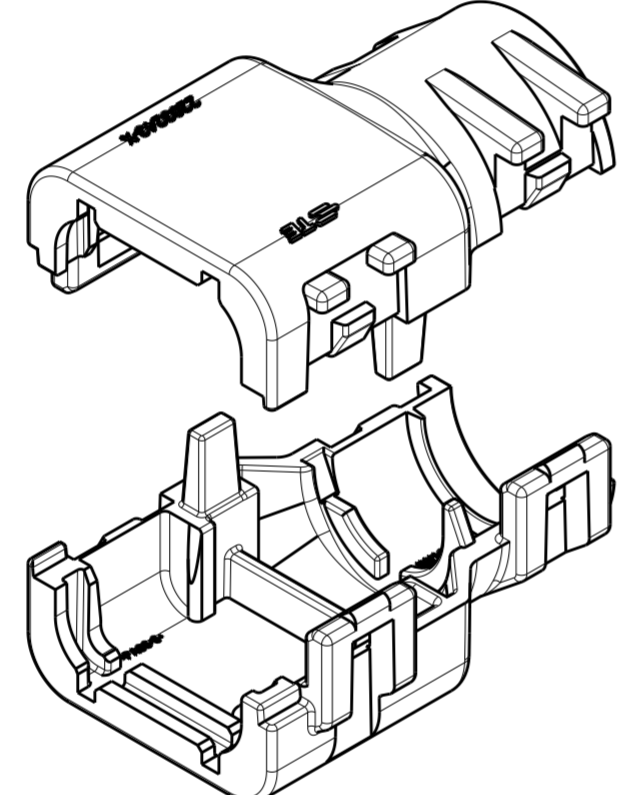

2292860-2
EXPLODED ISOMETRIC VIEW SHOWN

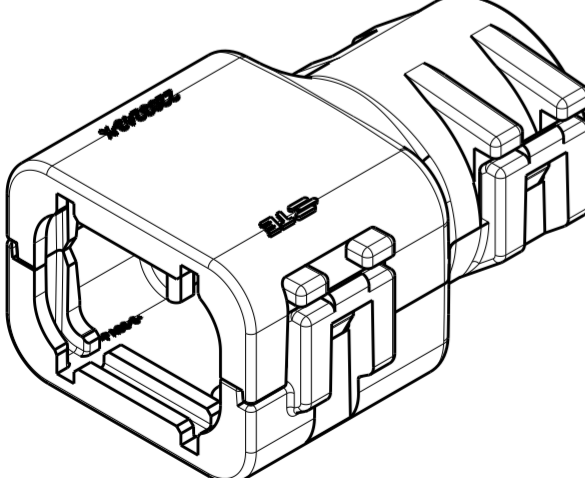

2292860-3
ASSEMBLED ISOMETRIC VIEW SHOWN

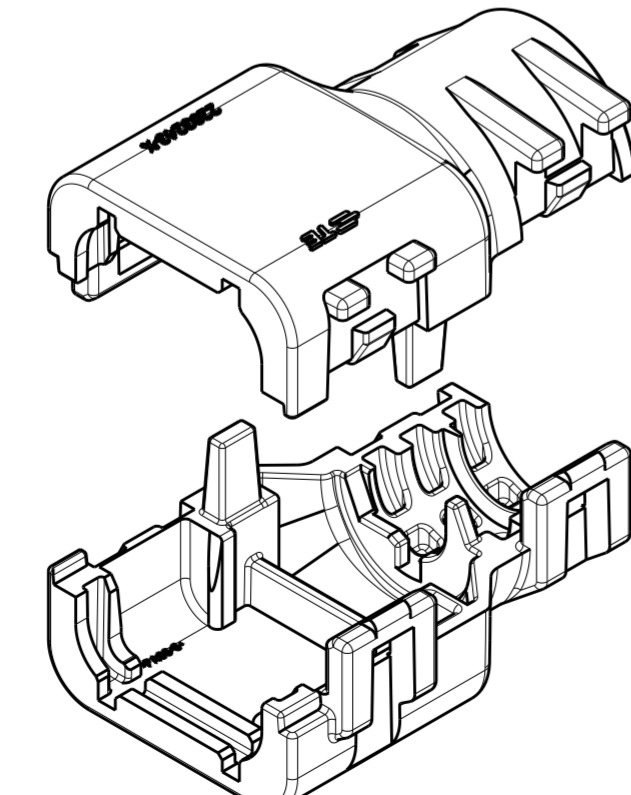

2292860-3
EXPLODED ISOMETRIC VIEW SHOWN

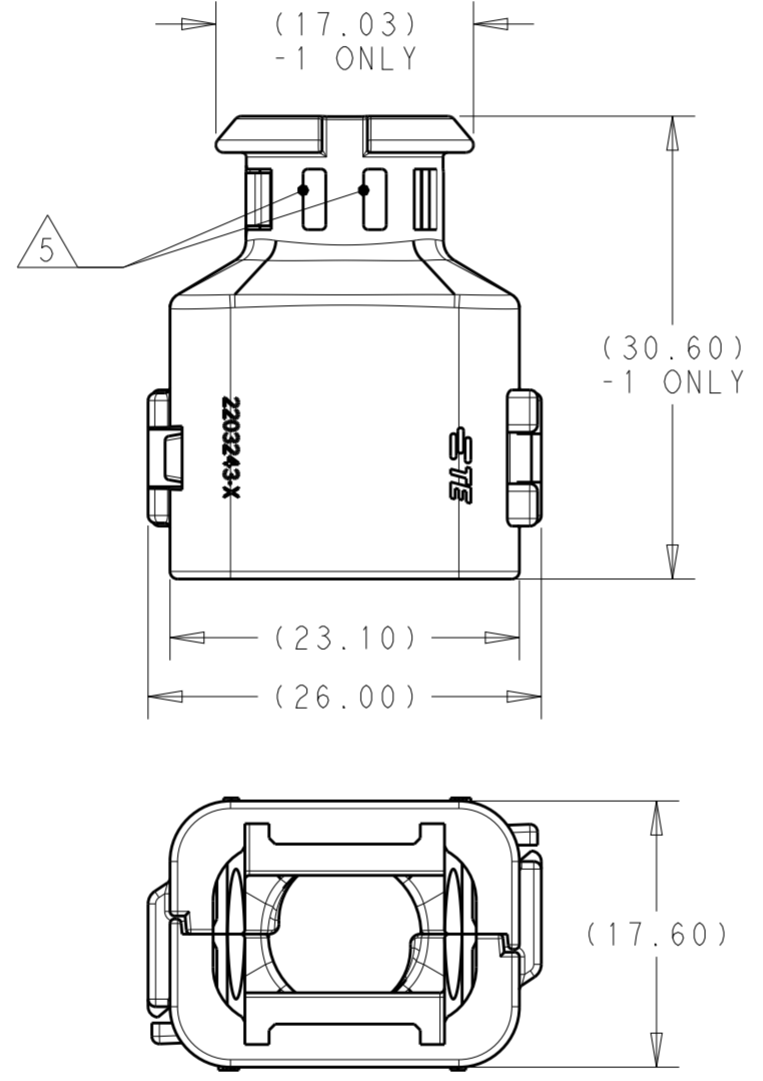

2292860-1
ASSEMBLED VIEW SHOWN

DIMENSIONS SHOWN TYPICAL FOR ALL PART NUMBERS ³ EXCEPT AS NOTED

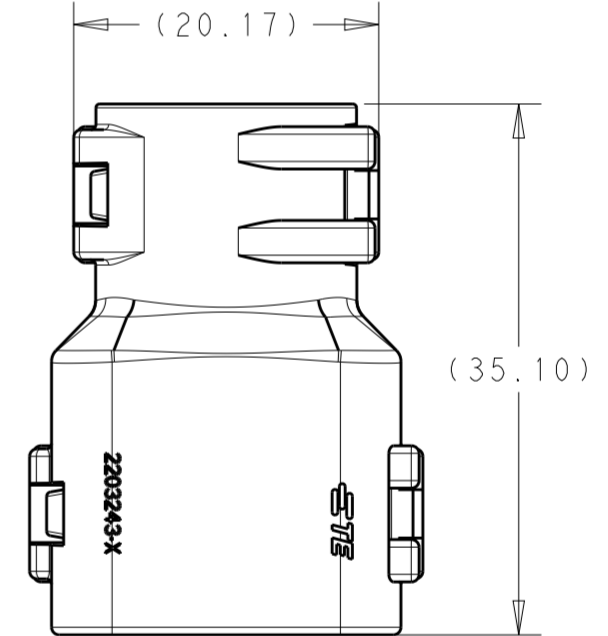
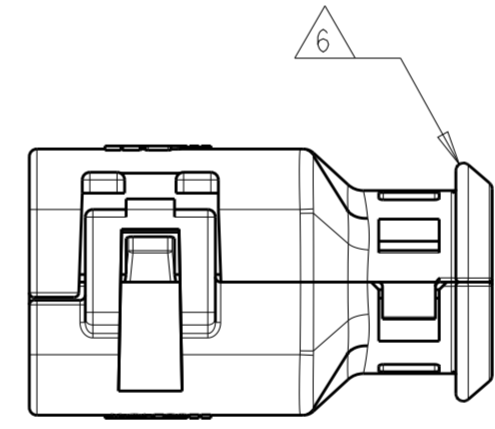

2292860-2
ASSEMBLED VIEW SHOWN

DIMENSIONS SHOWN TYPICAL FOR -2 AND -3 ONLY ³

- ¹ MATERIAL: NYLON MOLDING COMPOUND, BLACK, PA66/6.
- ² BACKSHELL DESIGNED SUCH THAT TWO HALVES ATTACH TO ONE ANOTHER AND CLAMP AROUND THE CONNECTOR COVER.
- ³ DIMENSIONS TO BE MEASURED WHEN BACKSHELLS ASSEMBLED.
- ⁴ PRODUCT WEIGHTS:
 2292860-1: 3.90g ASSEMBLED
 2292860-2: 5.10g ASSEMBLED
 2292860-3: 5.65g ASSEMBLED
- ⁵ 4mm WIDE SLOTS FOR TIE WRAP TO SECURE HARNESS WIRES (-1 ONLY).
- ⁶ HEAT SHRINK TUBING RETENTION FEATURE (-1 ONLY).
- 7. INSTRUCTION SHEET: 408-151043.
- 8. CONDUIT PROFILE: NORMAL ONLY

776428-X	NC08	NW7.5	2292860-3
776534-X	NC12	NW10	2292860-2
	SMOOTH	SMOOTH	2292860-1
FITS ON CAP ASSY	CORRUGATE NC	CORRUGATE NW	PART NUMBER
	CONDUIT SIZE		

THIS DRAWING IS A CONTROLLED DOCUMENT.		DWN J MCNEAL 19MAY2015	STE TE Connectivity	
		CHK R BALTER 19MAY2015		
		APVD R BALTER 19MAY2015	NAME CAP ASSEMBLY, BACKSHELL KIT, 2 POSITION, AMPSEAL 16	
DIMENSIONS: mm		PRODUCT SPEC 108-151043	SIZE CAGE CODE DRAWING NO	
TOLERANCES UNLESS OTHERWISE SPECIFIED:		APPLICATION SPEC -	RESTRICTED TO	
0 PLC ±		WEIGHT ⁴	A200779 C-2292860	
1 PLC ±		CUSTOMER DRAWING	SCALE 2:1 SHEET 1 OF 2 REV A2	
2 PLC ±				
3 PLC ±				
4 PLC ±				
ANGLES ±				
FINISH -				
- ¹				

THIS DRAWING IS UNPUBLISHED. RELEASED FOR PUBLICATION 20
 © COPYRIGHT 20 BY - ALL RIGHTS RESERVED.

REVISIONS				
P	LTR	DESCRIPTION	DATE	APVD
-	-	SEE SHEET 1	-	-

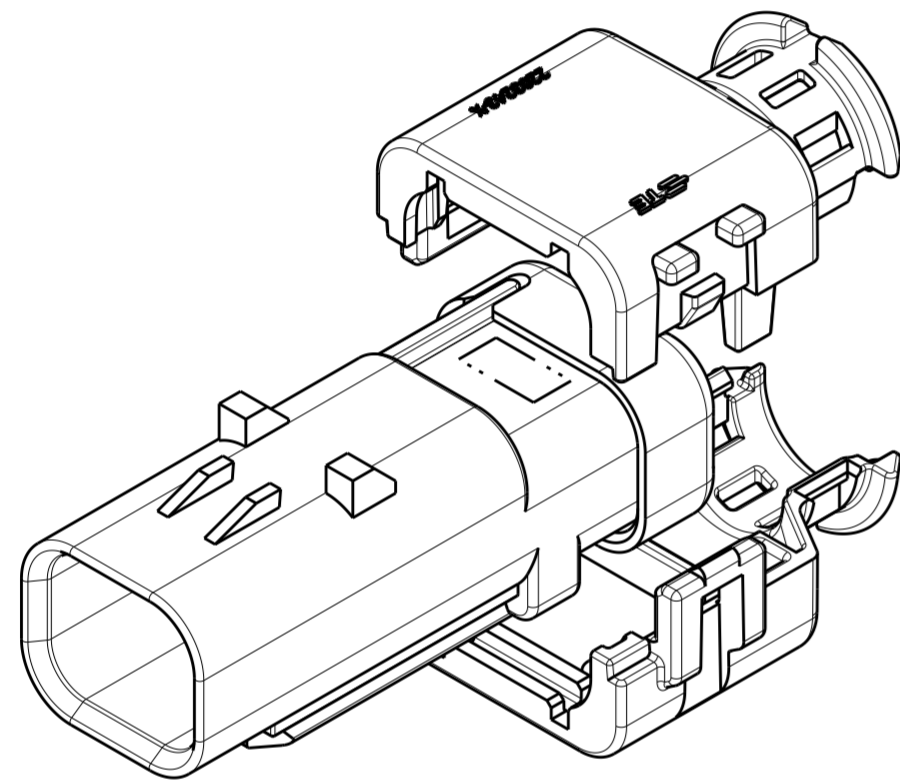

2292860-1

WITH CAP ASSEMBLY 
 EXPLODED ISOMETRIC VIEW SHOWN

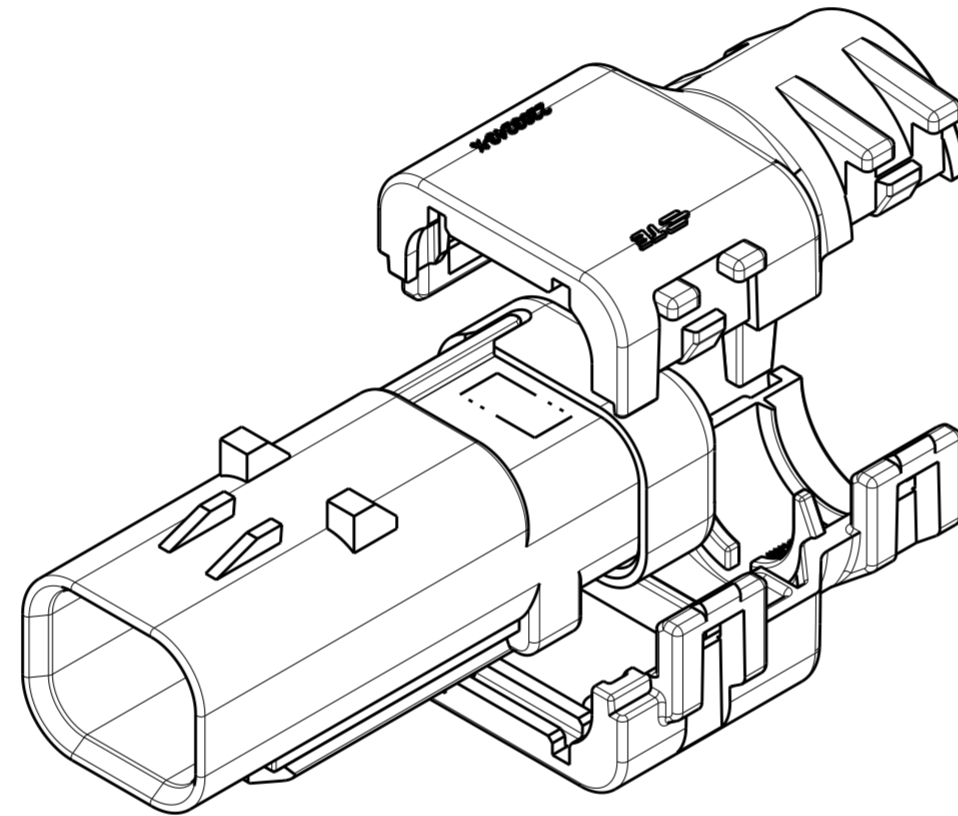

2292860-2

WITH CAP ASSEMBLY 
 EXPLODED ISOMETRIC VIEW SHOWN

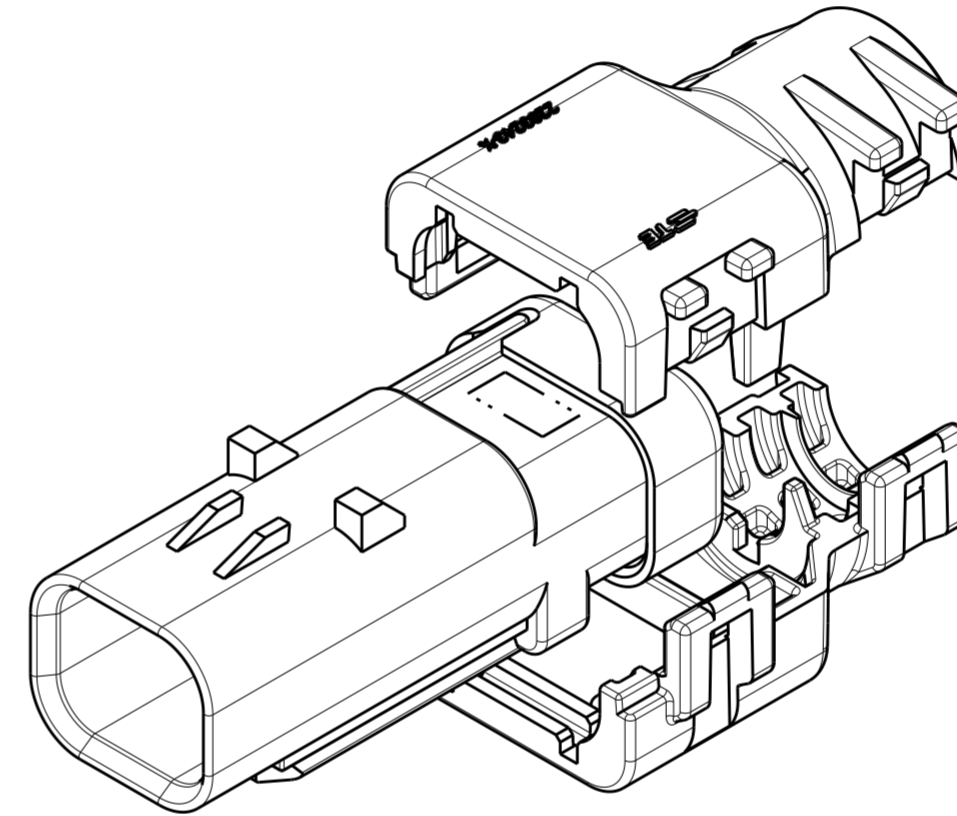

2292860-3

WITH CAP ASSEMBLY 
 EXPLODED ISOMETRIC VIEW SHOWN

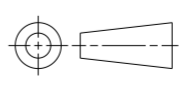
THIS DRAWING IS A CONTROLLED DOCUMENT.		DWN J. MCNEAL 19MAY2015	 TE Connectivity	
DIMENSIONS:		CHK R. BALTER 19MAY2015		
mm	TOLERANCES UNLESS OTHERWISE SPECIFIED:	APVD R. BALTER 19MAY2015	NAME CAP ASSEMBLY, BACKSHELL KIT, 2 POSITION, AMPSEAL 16	
	0 PLC ± 1 PLC ± 2 PLC ± 3 PLC ± 4 PLC ± ANGLES ± FINISH	PRODUCT SPEC 108-151043	SIZE A2	CAGE CODE 00779
MATERIAL	-	APPLICATION SPEC -	DRAWING NO C-2292860	RESTRICTED TO -
-	-	WEIGHT	SCALE 2:1 SHEET 2 OF 2 REV A2	
-	-	CUSTOMER DRAWING		