



Chipsmall Limited consists of a professional team with an average of over 10 year of expertise in the distribution of electronic components. Based in Hongkong, we have already established firm and mutual-benefit business relationships with customers from,Europe,America and south Asia,supplying obsolete and hard-to-find components to meet their specific needs.

With the principle of “Quality Parts,Customers Priority,Honest Operation,and Considerate Service”,our business mainly focus on the distribution of electronic components. Line cards we deal with include Microchip,ALPS,ROHM,Xilinx,Pulse,ON,Everlight and Freescale. Main products comprise IC,Modules,Potentiometer,IC Socket,Relay,Connector.Our parts cover such applications as commercial,industrial, and automotives areas.

We are looking forward to setting up business relationship with you and hope to provide you with the best service and solution. Let us make a better world for our industry!



Contact us

Tel: +86-755-8981 8866 Fax: +86-755-8427 6832

Email & Skype: info@chipsmall.com Web: www.chipsmall.com

Address: A1208, Overseas Decoration Building, #122 Zhenhua RD., Futian, Shenzhen, China



REVISIONS				
P.	LTN	DESCRIPTION	DATE	APVD
A1		REV PER ECO-16-008350	02JUN2016	JM RB
A2		REV PER ECO-16-013256	08SEP2016	JM RB

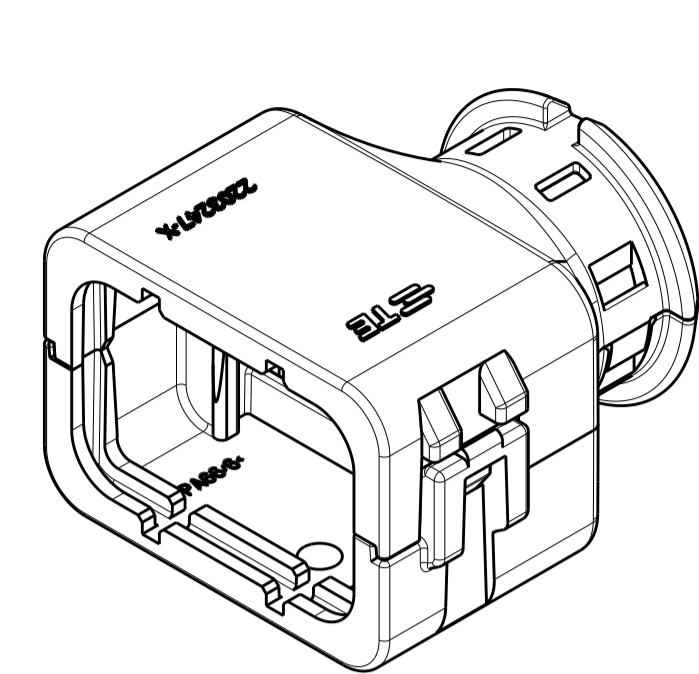

2292864-1
ASSEMBLED ISOMETRIC VIEW SHOWN

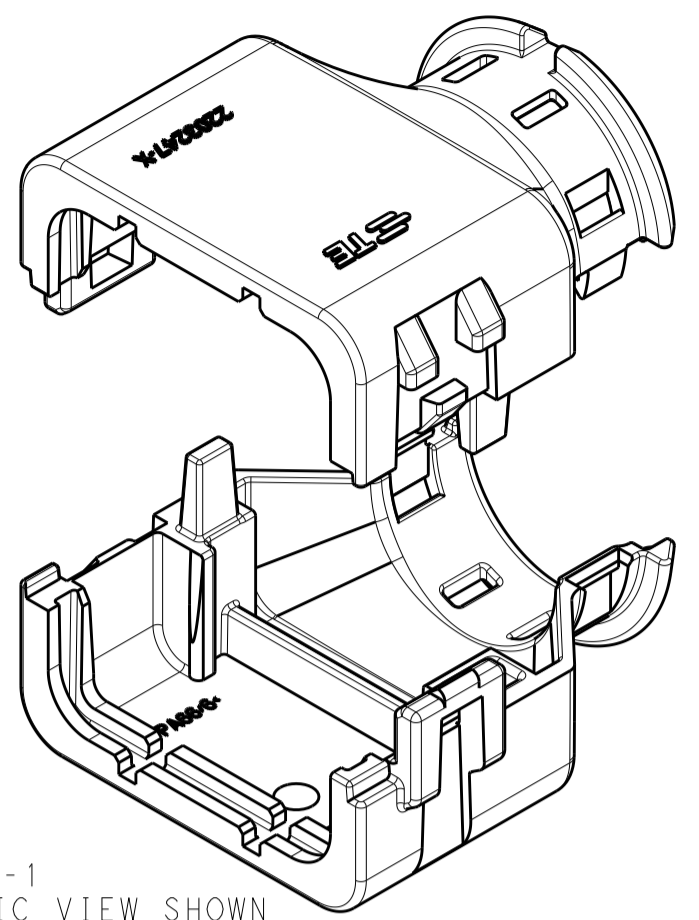

2292864-1
EXPLODED ISOMETRIC VIEW SHOWN

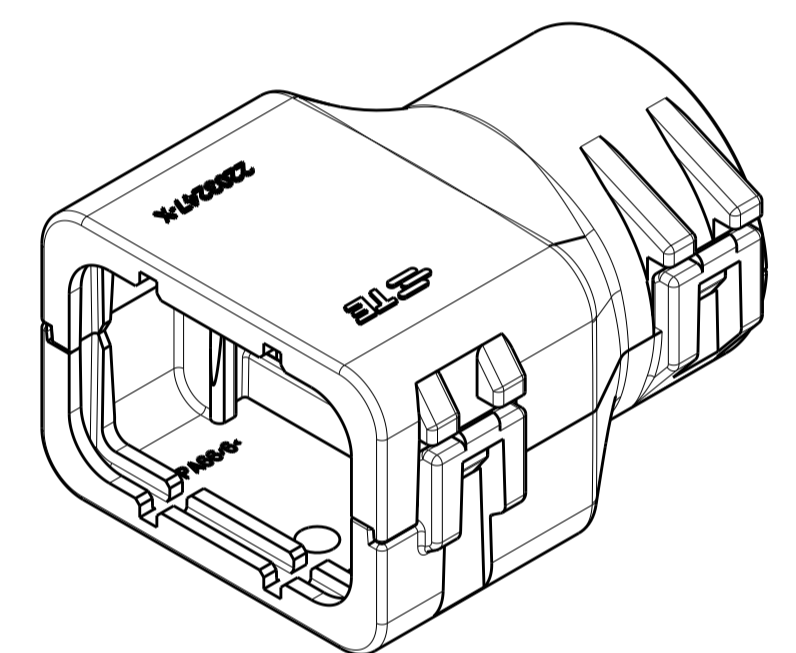

2292864-2
ASSEMBLED ISOMETRIC VIEW SHOWN

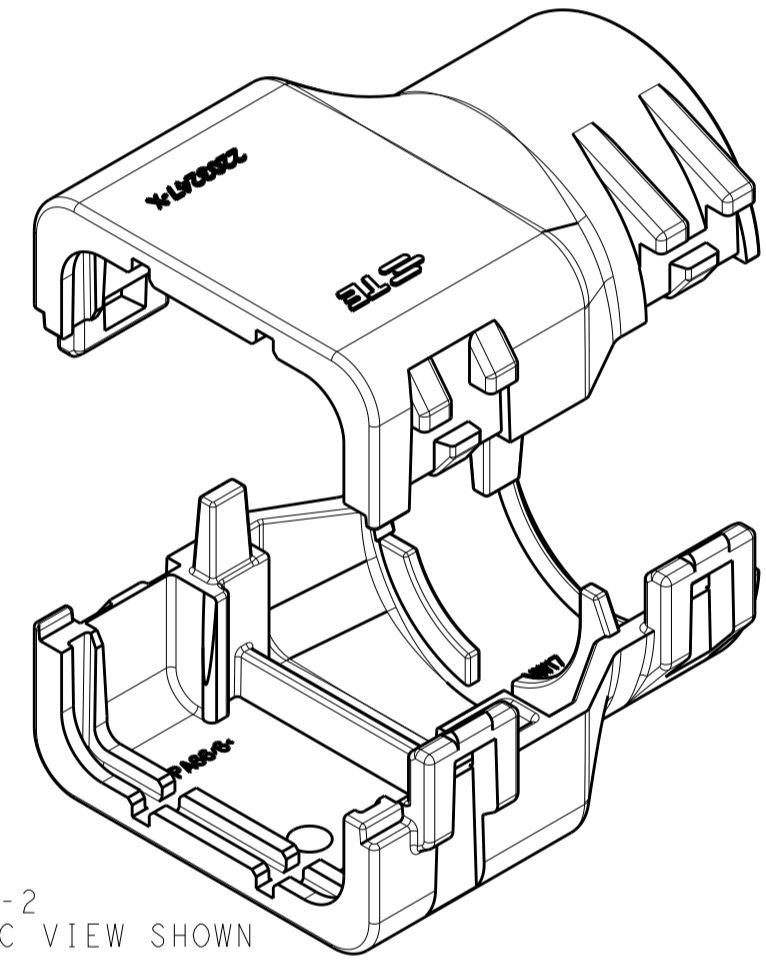

2292864-2
EXPLODED ISOMETRIC VIEW SHOWN

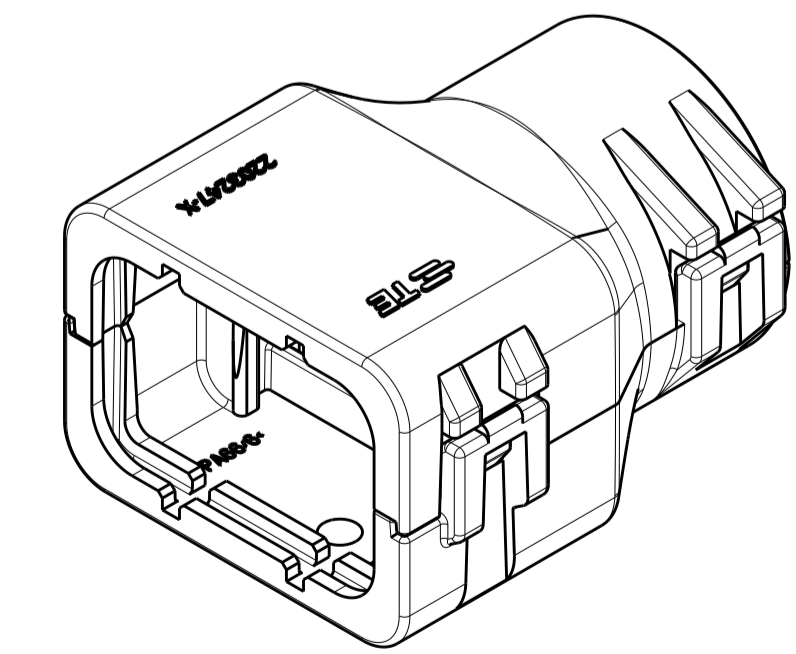

2292864-3
ASSEMBLED ISOMETRIC VIEW SHOWN

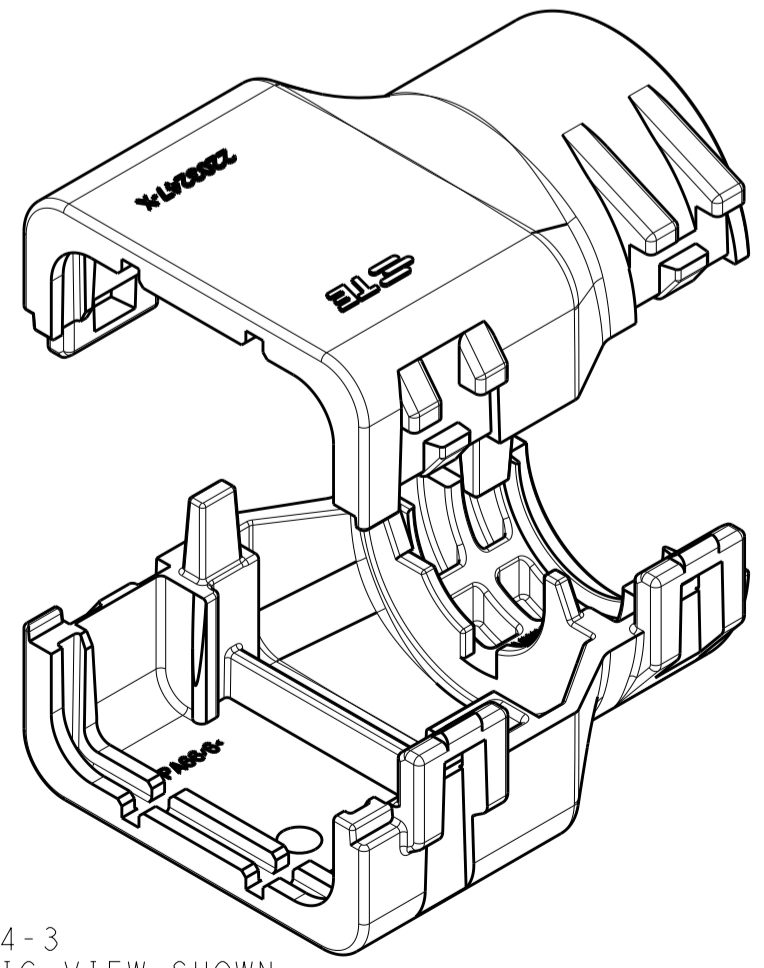

2292864-3
EXPLODED ISOMETRIC VIEW SHOWN

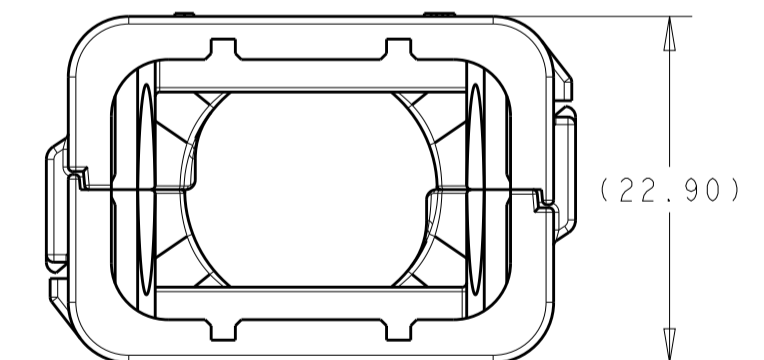
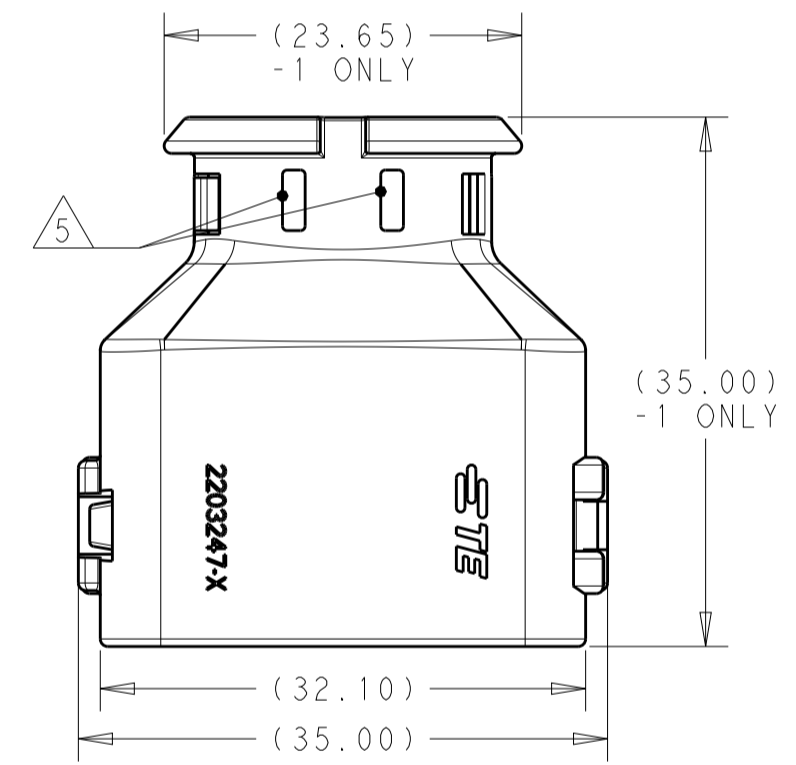

2292864-1
ASSEMBLED VIEW SHOWN

DIMENSIONS SHOWN TYPICAL FOR ALL PART NUMBERS ³
EXCEPT AS NOTED

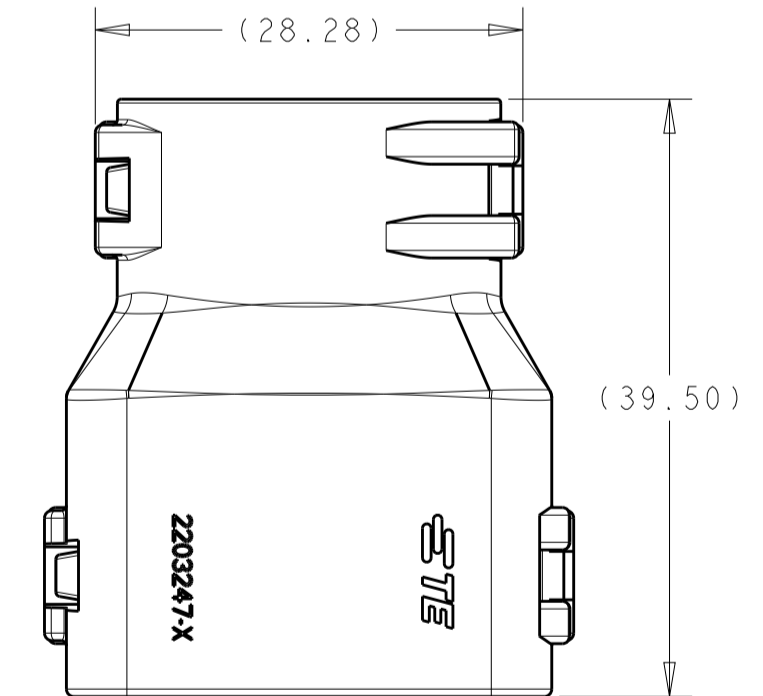
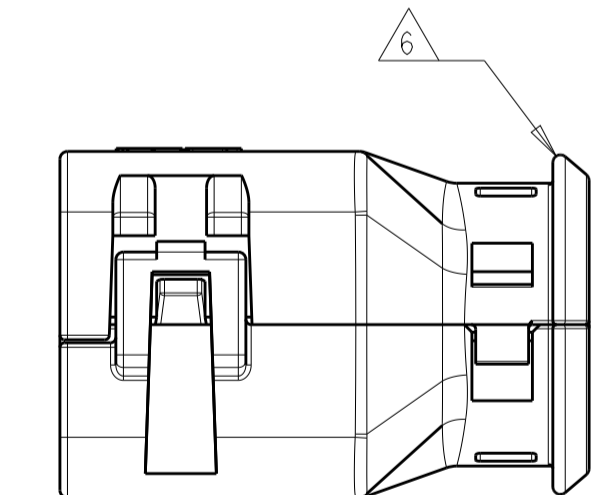

2292864-2
ASSEMBLED VIEW SHOWN

DIMENSIONS SHOWN TYPICAL FOR -2 AND -3 ONLY ³

- ¹ MATERIAL: NYLON MOLDING COMPOUND, BLACK, PA66/6.
- ² BACKSHELL DESIGNED SUCH THAT TWO HALVES ATTACH TO ONE ANOTHER AND CLAMP AROUND THE CONNECTOR COVER.
- ³ DIMENSIONS TO BE MEASURED WHEN BACKSHELLS ASSEMBLED.
- ⁴ PRODUCT WEIGHTS:
2292864-1: 6.30g ASSEMBLED
2292864-2: 7.98g ASSEMBLED
2292864-3: 9.30g ASSEMBLED
- ⁵ 4mm WIDE SLOTS FOR TIE WRAP TO SECURE HARNESS WIRES (-1 ONLY).
- ⁶ HEAT SHRINK TUBING RETENTION FEATURE (-1 ONLY).
- 7. INSTRUCTION SHEET: 408-151043.
- 8. CONDUIT PROFILE: NORMAL ONLY.

776495-X	NC16	NW13	2292864-3
776538-X	NC20	NW17	2292864-2
	SMOOTH	SMOOTH	2292864-1
FITS ON CAP ASSY	CORREGATE NC	CORREGATE NW	PART NUMBER
	CONDUIT SIZE		

THIS DRAWING IS A CONTROLLED DOCUMENT.		OWN J MCNEAL 19JUN2015	TE Connectivity	
DIMENSIONS: mm [INCHES]		CHK R BALTER 19JUN2015	NAME BACKSHELL KIT, 8 POSITION, CAP ASSY AMPSEAL 16	
TOLERANCES UNLESS OTHERWISE SPECIFIED:		APVD R BALTER 19JUN2015	PRODUCT SPEC 108-151043	
0 PLC ±		APPLICATION SPEC		
1 PLC ±		SIZE CAGE CODE DRAWING NO RESTRICTED TO		
2 PLC ±		A100779C=2292864		
3 PLC ±		WEIGHT ⁴		
4 PLC ±		CUSTOMER DRAWING SCALE 2:1 SHEET 1 OF 2 REV A2		
ANGLES ±				
FINISH ±				

THIS DRAWING IS UNPUBLISHED. RELEASED FOR PUBLICATION 20
 © COPYRIGHT 20 BY - ALL RIGHTS RESERVED.

REVISIONS				
P.	LTN	DESCRIPTION	DATE	APVD
-		SEE SHEET 1	-	-

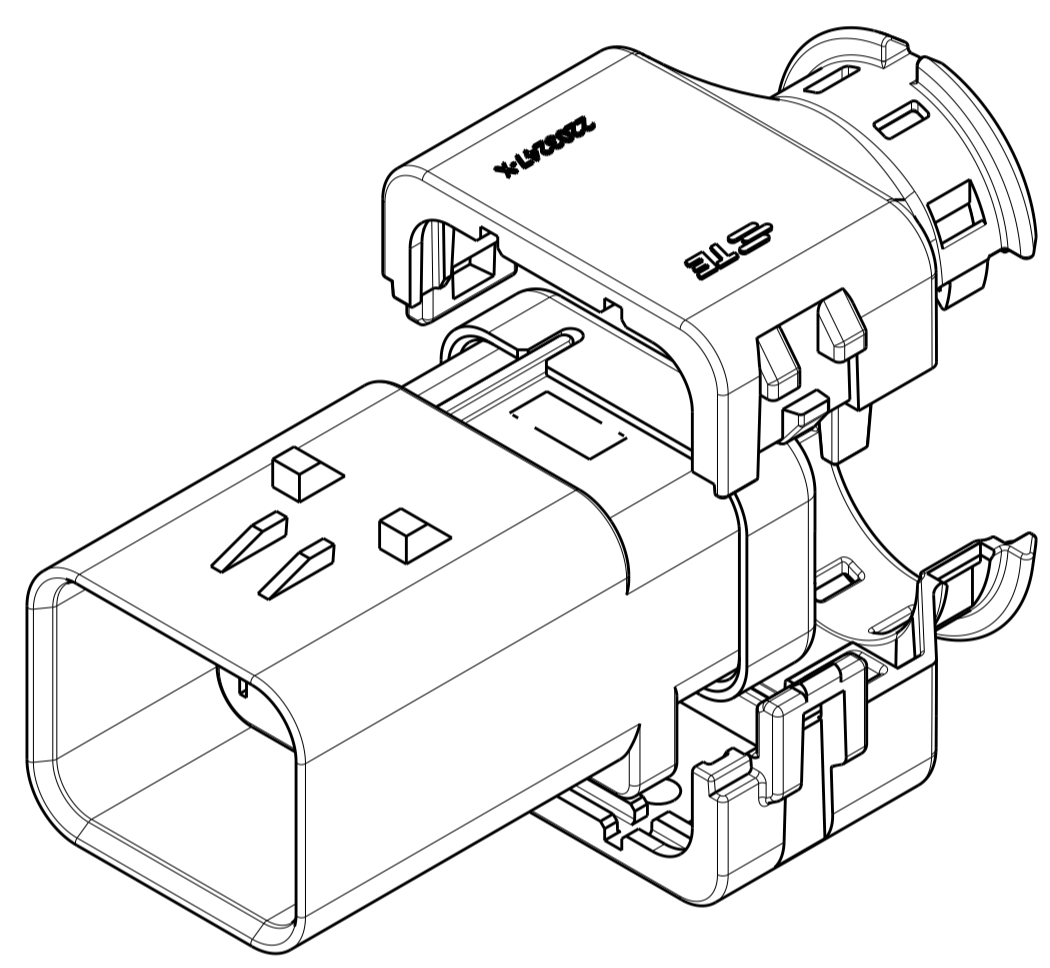

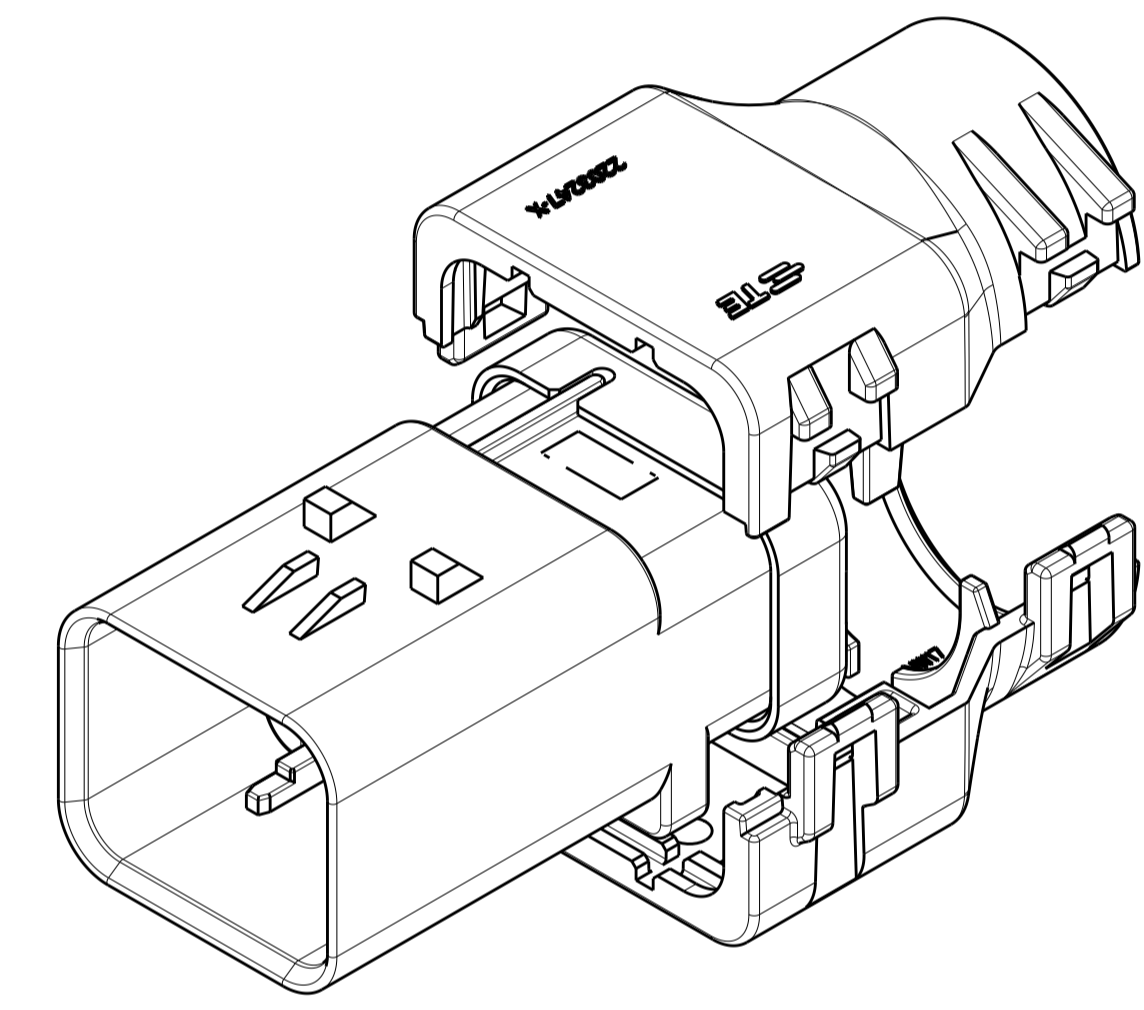

2292864-1
 WITH CAP ASSEMBLY 
 EXPLODED ISOMETRIC VIEW SHOWN

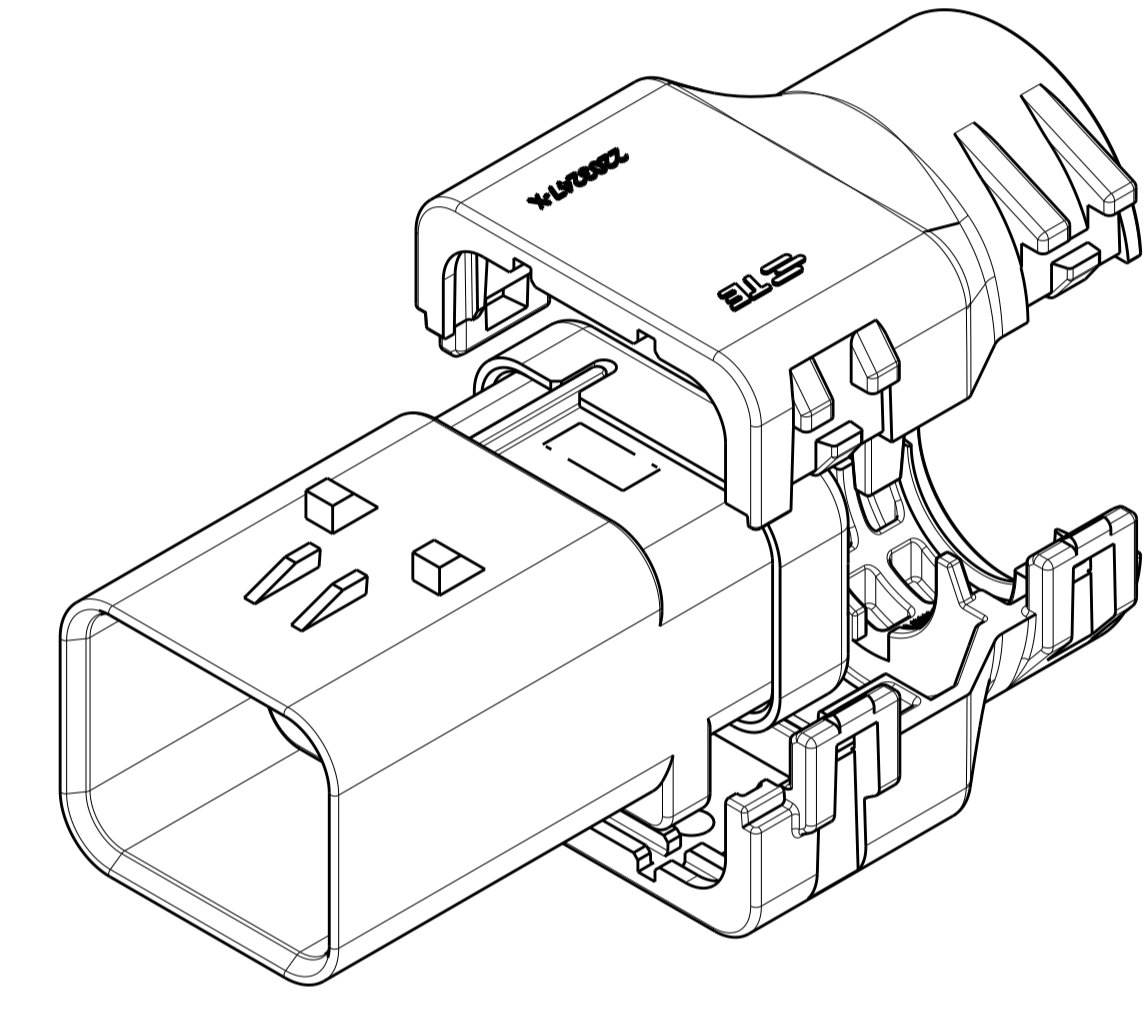

2292864-2
 WITH CAP ASSEMBLY 
 EXPLODED ISOMETRIC VIEW SHOWN



2292864-3
 WITH CAP ASSEMBLY 
 EXPLODED ISOMETRIC VIEW SHOWN

THIS DRAWING IS A CONTROLLED DOCUMENT.		DWN J MCNEAL 19JUN2015 CHK R BALTER 19JUN2015 APVD R BALTER 19JUN2015	 TE Connectivity
DIMENSIONS: mm [INCHES]	TOLERANCES UNLESS OTHERWISE SPECIFIED: 0 PLC ± 1 PLC ± 2 PLC ± 3 PLC ± 4 PLC ± ANGLES ±	NAME BACKSHELL KIT, 8 POSITION, CAP ASSY AMPSEAL 16 PRODUCT SPEC 108-151043 APPLICATION SPEC	
MATERIAL - FINISH -	WEIGHT - CUSTOMER DRAWING	SIZE A1 CAGE CODE 00779 DRAWING NO C=2292864	RESTRICTED TO - SCALE 2:1 SHEET 2 OF 2 REV A2