



Chipsmall Limited consists of a professional team with an average of over 10 year of expertise in the distribution of electronic components. Based in Hongkong, we have already established firm and mutual-benefit business relationships with customers from,Europe,America and south Asia,supplying obsolete and hard-to-find components to meet their specific needs.

With the principle of "Quality Parts,Customers Priority,Honest Operation,and Considerate Service",our business mainly focus on the distribution of electronic components. Line cards we deal with include Microchip,ALPS,ROHM,Xilinx,Pulse,ON,Everlight and Freescale. Main products comprise IC,Modules,Potentiometer,IC Socket,Relay,Connector.Our parts cover such applications as commercial,industrial, and automotives areas.

We are looking forward to setting up business relationship with you and hope to provide you with the best service and solution. Let us make a better world for our industry!



Contact us

Tel: +86-755-8981 8866 Fax: +86-755-8427 6832

Email & Skype: info@chipsmall.com Web: www.chipsmall.com

Address: A1208, Overseas Decoration Building, #122 Zhenhua RD., Futian, Shenzhen, China



UMK- PVB 2/48/ZFKDS

Order No.: 2302382

The illustration shows version UMK- PVB 2/16/ZFKDS

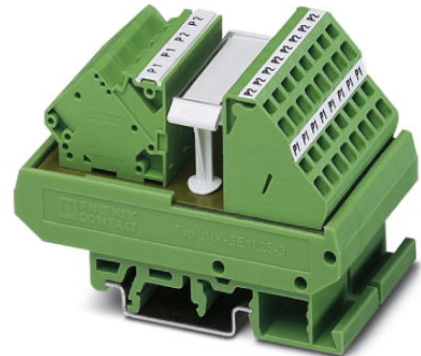

<http://eshop.phoenixcontact.de/phoenix/treeViewClick.do?UID=2302382>

VARIOFACE module, with two equipotential busbars (P1, P2) for potential distribution, for mounting on NS 35/7.5 or NS 32

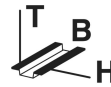

Commercial data	
GTIN (EAN)	
sales group	I110
Pack	1 pcs.
Customs tariff	85369010
Catalog page information	Page 297 (IF-2009)

Product notes

WEEE/RoHS-compliant since:
07/17/2006



<http://www.download.phoenixcontact.com>
Please note that the data given here has been taken from the online catalog. For comprehensive information and data, please refer to the user documentation. The General Terms and Conditions of Use apply to Internet downloads.

Technical data	
General data	
Nominal voltage U_N	250 V AC/DC
Width	135 mm
Height	77 mm

Depth	52 mm
Ambient temperature (operation)	-20 °C ... 50 °C
Ambient temperature (storage/transport)	-20 °C ... 70 °C
Mounting position	Any
Name	Air and creepage distances in a circuit
Standards/regulations	DIN EN 50178
Rated surge voltage / insulation	2.3 kV / basic insulation
Rated insulation voltage	260 V AC
Pollution degree	2
Surge voltage category	II

Connection data, supply

Conductor cross section solid min.	0.2 mm ²
Conductor cross section solid max.	6 mm ²
Conductor cross section stranded min.	0.2 mm ²
Conductor cross section stranded max.	4 mm ²
Conductor cross section AWG/kcmil min.	24
Conductor cross section AWG/kcmil max	10
Type of connection	Spring-cage connection
Stripping length	8 mm

Connection data, distribution

Conductor cross section solid min.	0.2 mm ²
Conductor cross section solid max.	4 mm ²
Conductor cross section stranded min.	0.2 mm ²
Conductor cross section stranded max.	2.5 mm ²
Conductor cross section AWG/kcmil min.	24
Conductor cross section AWG/kcmil max	12
Stripping length	8 mm

Certificates / Approvals



Certification

CUL, GOST, UL

Accessories

Item	Designation	Description
------	-------------	-------------

Tools

1204517	SZF 1-0,6X3,5	Actuation tool, for ST terminal blocks, also suitable for use as a bladed screwdriver, size: 0.6 x 3.5 x 100 mm, 2-component grip, with non-slip grip
---------	---------------	---

Diagrams/Drawings

Circuit diagram

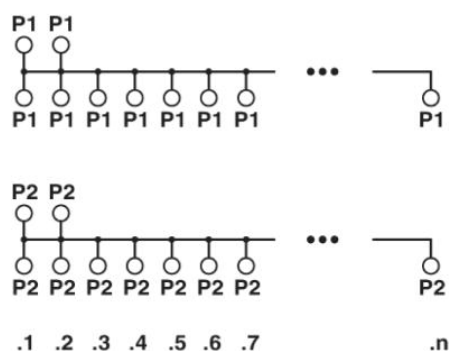

Address

PHOENIX CONTACT Deutschland GmbH
Flachmarktstr. 8
32825 Blomberg, Germany
Phone +49 5235 3 12000
Fax +49 5235 3 41200
<http://www.phoenixcontact.de>



© 2011 Phoenix Contact
Technical modifications reserved;