



Chipsmall Limited consists of a professional team with an average of over 10 year of expertise in the distribution of electronic components. Based in Hongkong, we have already established firm and mutual-benefit business relationships with customers from,Europe,America and south Asia,supplying obsolete and hard-to-find components to meet their specific needs.

With the principle of “Quality Parts,Customers Priority,Honest Operation,and Considerate Service”,our business mainly focus on the distribution of electronic components. Line cards we deal with include Microchip,ALPS,ROHM,Xilinx,Pulse,ON,Everlight and Freescale. Main products comprise IC,Modules,Potentiometer,IC Socket,Relay,Connector.Our parts cover such applications as commercial,industrial, and automotives areas.

We are looking forward to setting up business relationship with you and hope to provide you with the best service and solution. Let us make a better world for our industry!



Contact us

Tel: +86-755-8981 8866 Fax: +86-755-8427 6832

Email & Skype: info@chipsmall.com Web: www.chipsmall.com

Address: A1208, Overseas Decoration Building, #122 Zhenhua RD., Futian, Shenzhen, China



REVISIONS				
P	LTN	DESCRIPTION	DATE	APVD
A		RELEASED PER ECO-16-007279	12MAY2016	JM RB
A2		REV PER ECO-16-013256	08SEP2016	JM RB

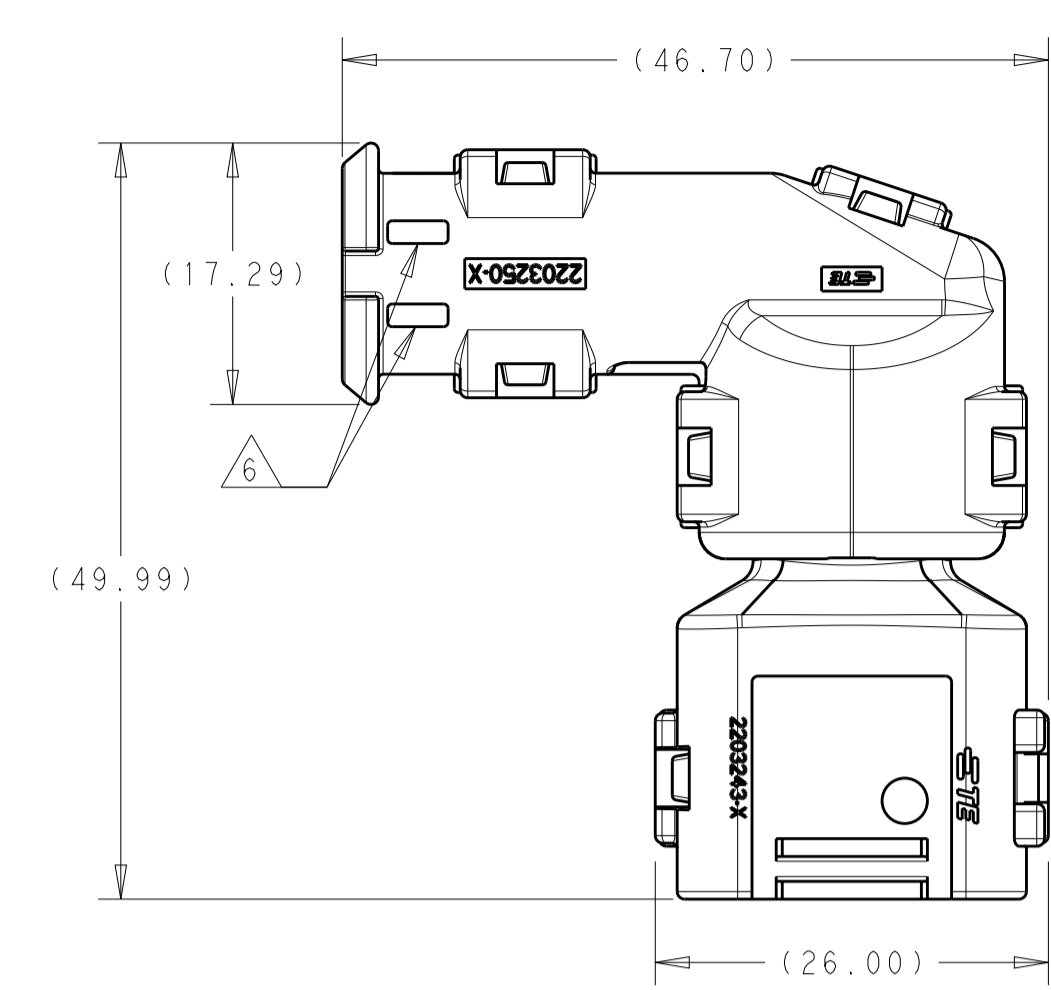
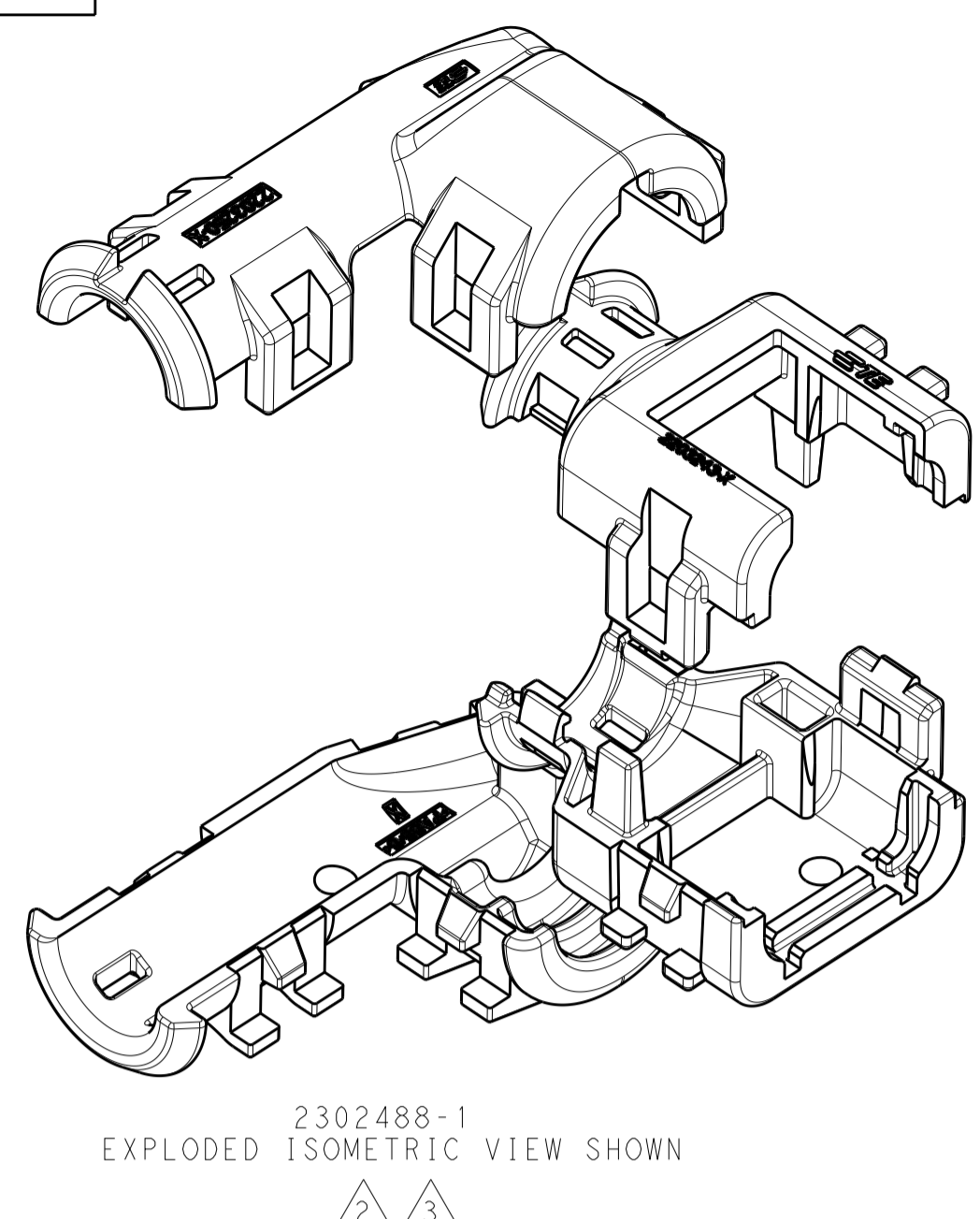
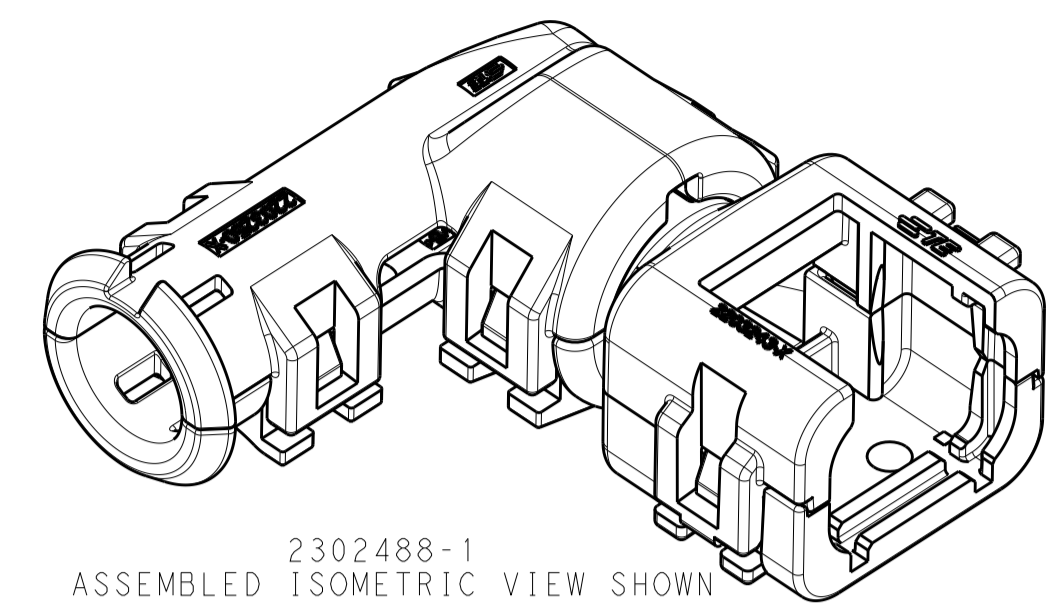

- 1 MATERIAL: NYLON MOLDING COMPOUND, BLACK, PA66/6.
- 2 BACKSHELL DESIGNED SUCH THAT TWO HALVES ATTACH TO ONE ANOTHER AND CLAMP AROUND THE CONNECTOR COVER.
- 3 ELBOW DESIGNED SUCH THAT TWO HALVES ATTACH TO ONE ANOTHER AND CLAMP AROUND THE BACKSHELL COLLAR.
- 4 DIMENSIONS TO BE MEASURED WHEN ELBOWS AND BACKSHELLS ASSEMBLED.
- 5 PRODUCT WEIGHTS:
 2302488-1: 9.10g ASSEMBLED
 2302488-2: 9.75g ASSEMBLED
 2302488-3: 9.20g ASSEMBLED
- 6 4mm WIDE SLOTS FOR TIE WRAP TO SECURE HARNESS WIRES (-1 ONLY).
- 7 HEAT SHRINK TUBING FEATURE (-1 AND -3 ONLY).
- 8. INSTRUCTION SHEET: 408-151043.
- 9. CONDUIT PROFILE: NORMAL ONLY.

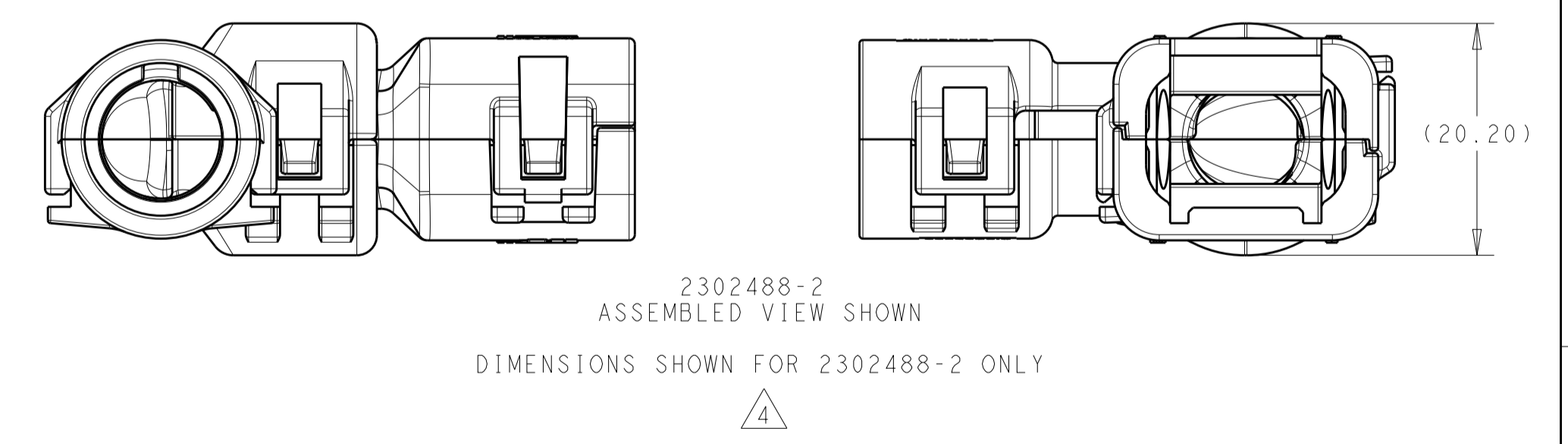
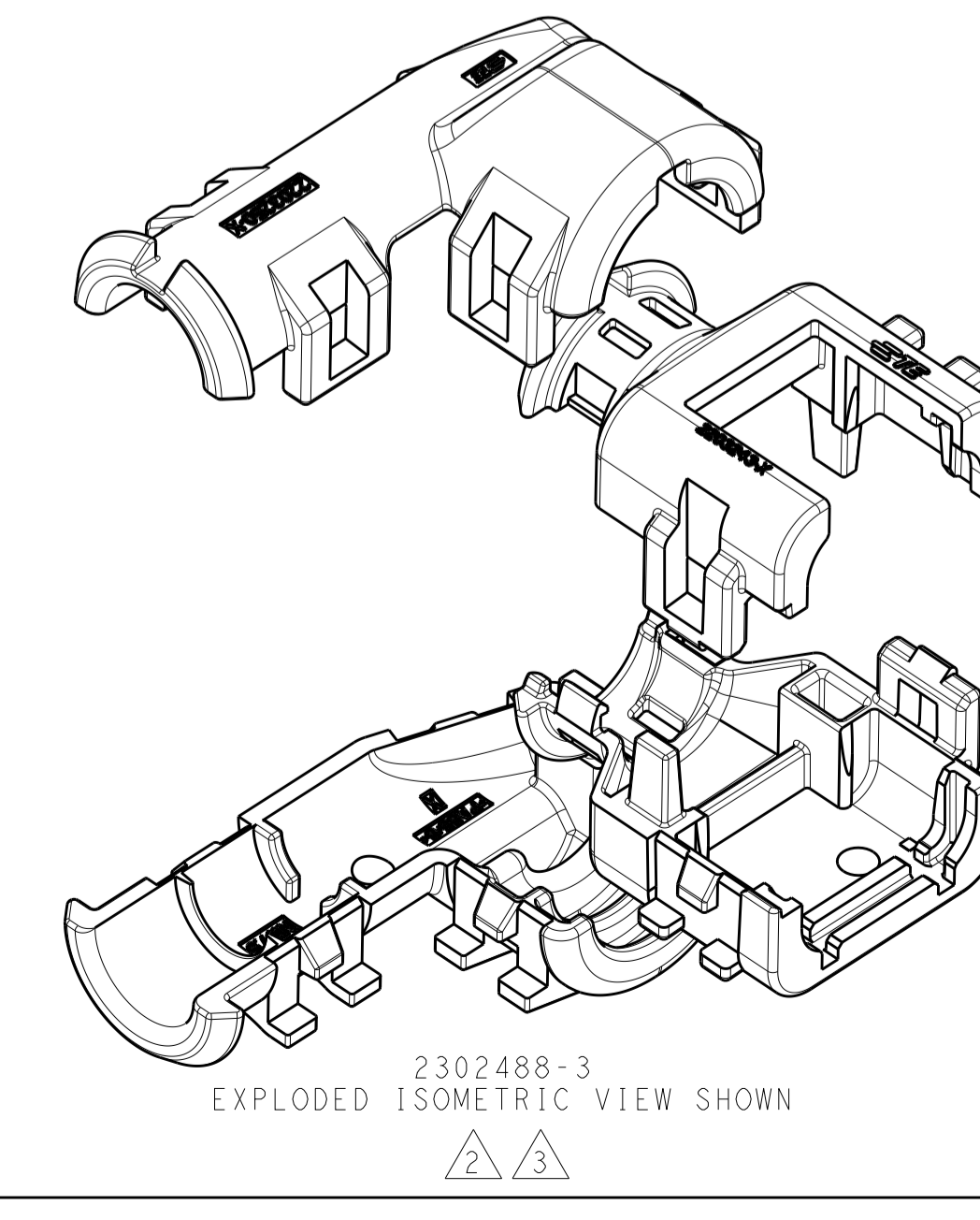
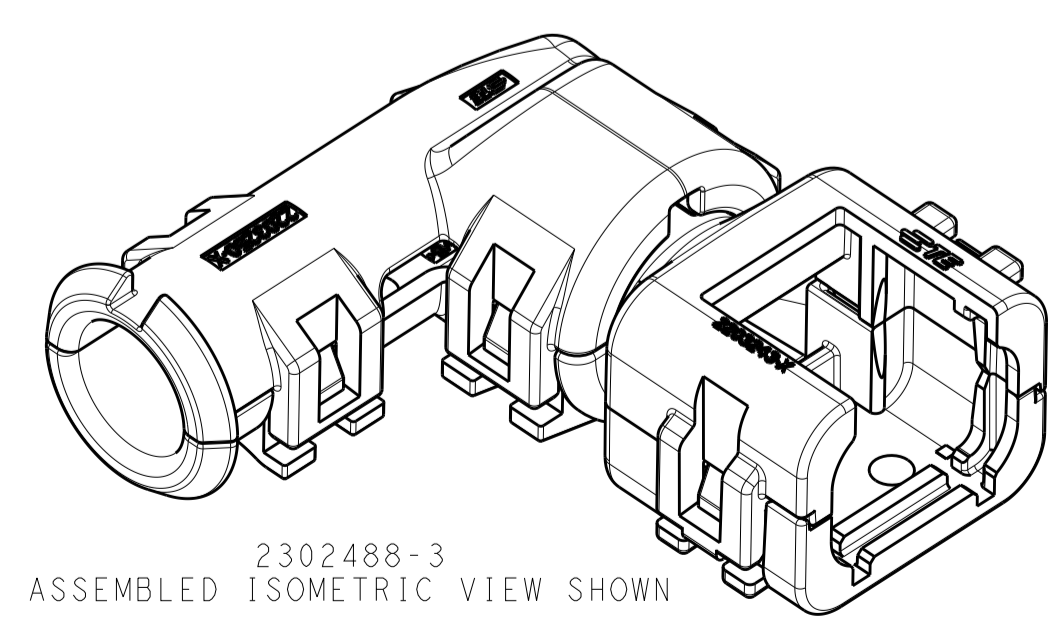
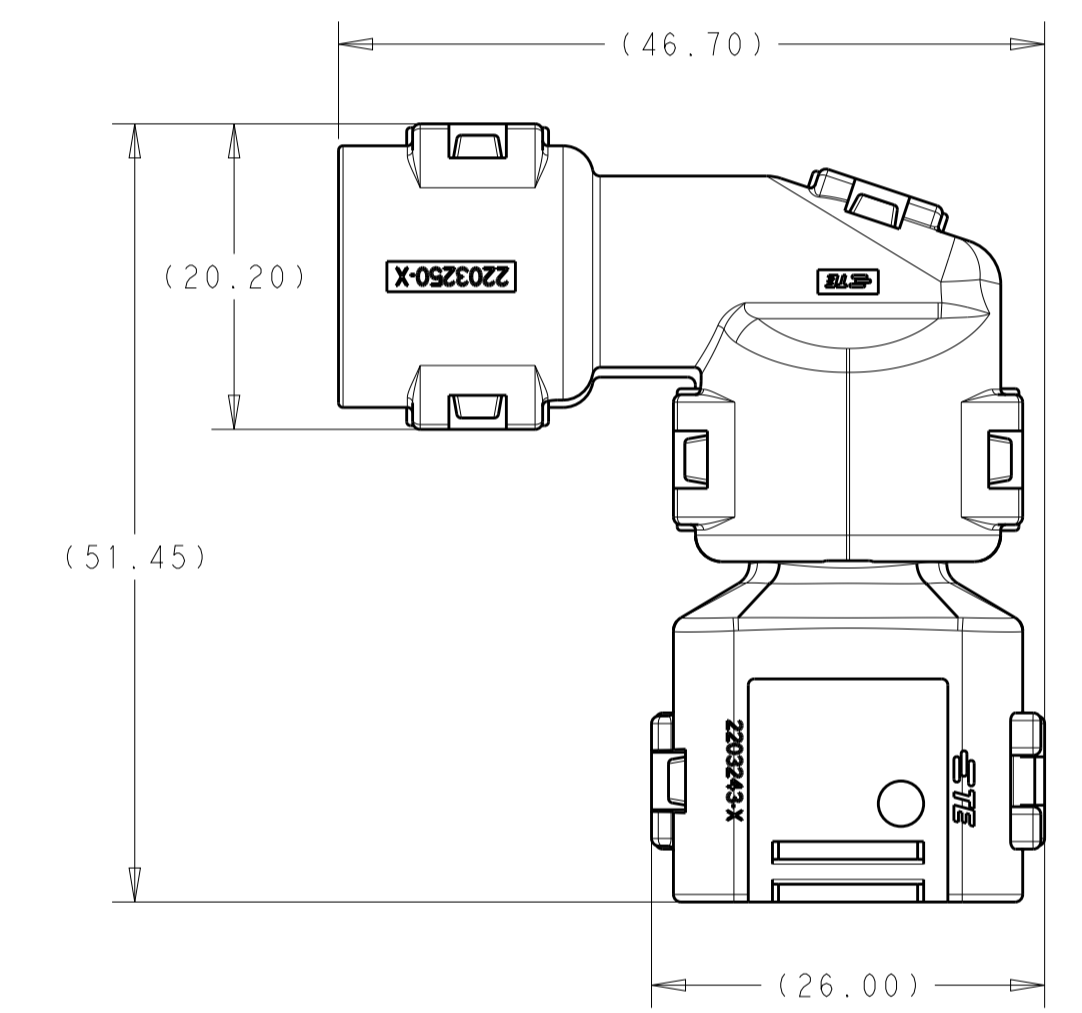
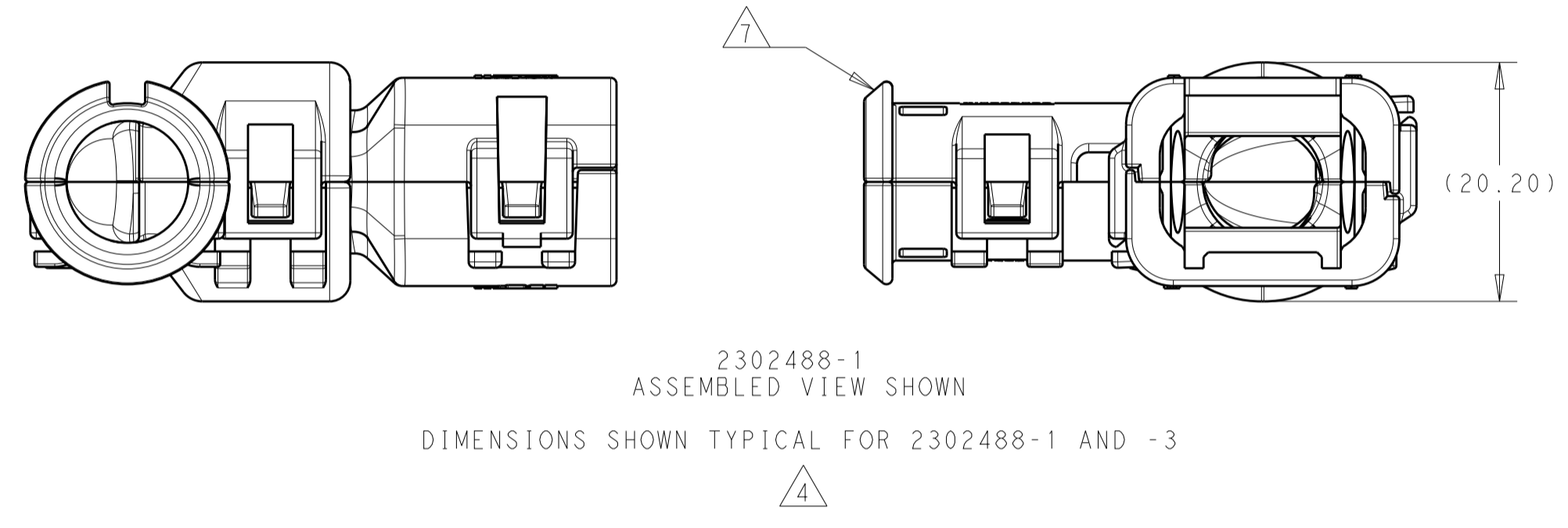
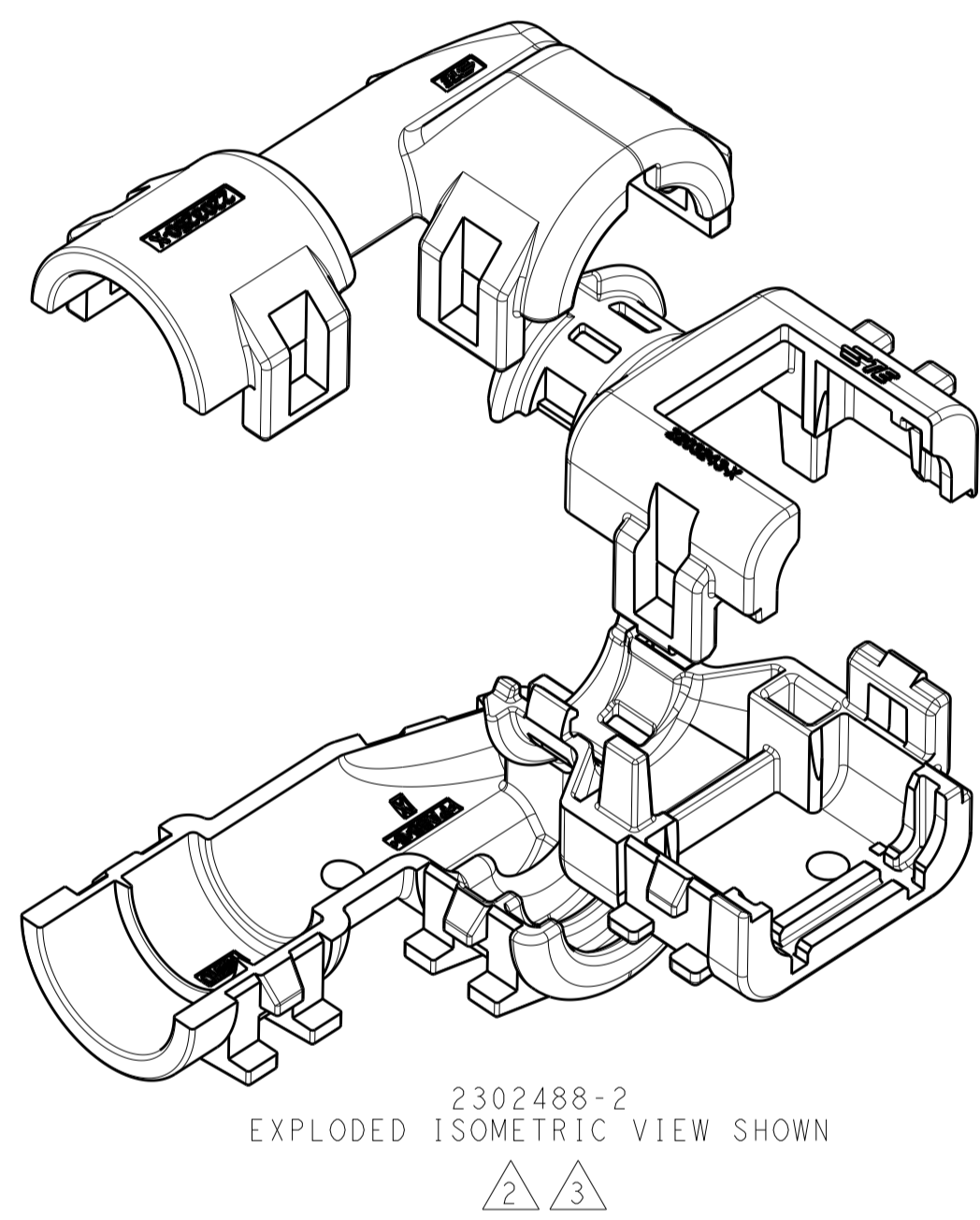
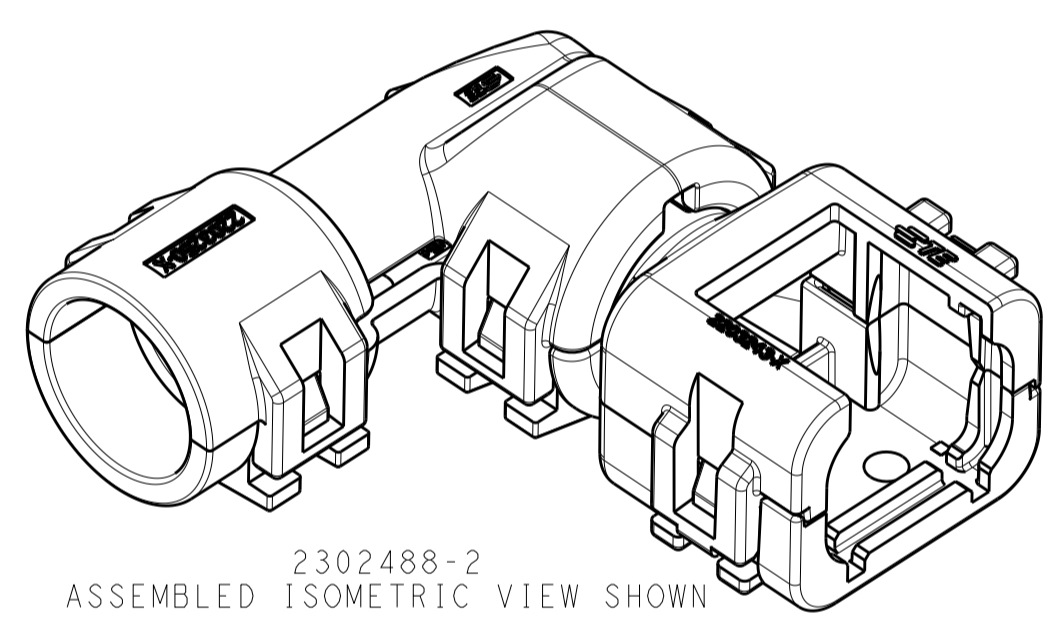

776427-X	NC08	NW7.5	2302488-3
776522-X	NC12	NW10	2302488-2
	SMOOTH	SMOOTH	2302488-1
FITS ON PLUG ASSY	CORREGATE NC	CORREGATE NW	PART NUMBER
	CONDUIT SIZE		

THIS DRAWING IS A CONTROLLED DOCUMENT.		OWN J. MCNEAL 13APR2016	TE Connectivity	
DIMENSIONS:		CHK R. BALTER 13APR2016	NAME	
mm	0 PLC ±	APVD R. BALTER 13APR2016	PRODUCT SPEC	
	1 PLC ±		APPLICATION SPEC	
	2 PLC ±		SIZE CAGE CODE DRAWING NO	
	3 PLC ±		RESTRICTED TO	
	4 PLC ±		WEIGHT	
	ANGLES ±		CUSTOMER DRAWING	
	FINISH		SCALE 2:1 SHEET 1 OF 1 REV A2	