



Chipsmall Limited consists of a professional team with an average of over 10 year of expertise in the distribution of electronic components. Based in Hongkong, we have already established firm and mutual-benefit business relationships with customers from,Europe,America and south Asia,supplying obsolete and hard-to-find components to meet their specific needs.

With the principle of “Quality Parts,Customers Priority,Honest Operation,and Considerate Service”,our business mainly focus on the distribution of electronic components. Line cards we deal with include Microchip,ALPS,ROHM,Xilinx,Pulse,ON,Everlight and Freescale. Main products comprise IC,Modules,Potentiometer,IC Socket,Relay,Connector.Our parts cover such applications as commercial,industrial, and automotives areas.

We are looking forward to setting up business relationship with you and hope to provide you with the best service and solution. Let us make a better world for our industry!



## Contact us

Tel: +86-755-8981 8866 Fax: +86-755-8427 6832

Email & Skype: info@chipsmall.com Web: www.chipsmall.com

Address: A1208, Overseas Decoration Building, #122 Zhenhua RD., Futian, Shenzhen, China





REVISIONS				
P	LTN	DESCRIPTION	DATE	APVD
A		RELEASED PER ECO-16-008203	01JUN2016	JM RB
A2		REV PER ECO-16-013256	08SEP2016	JM RB

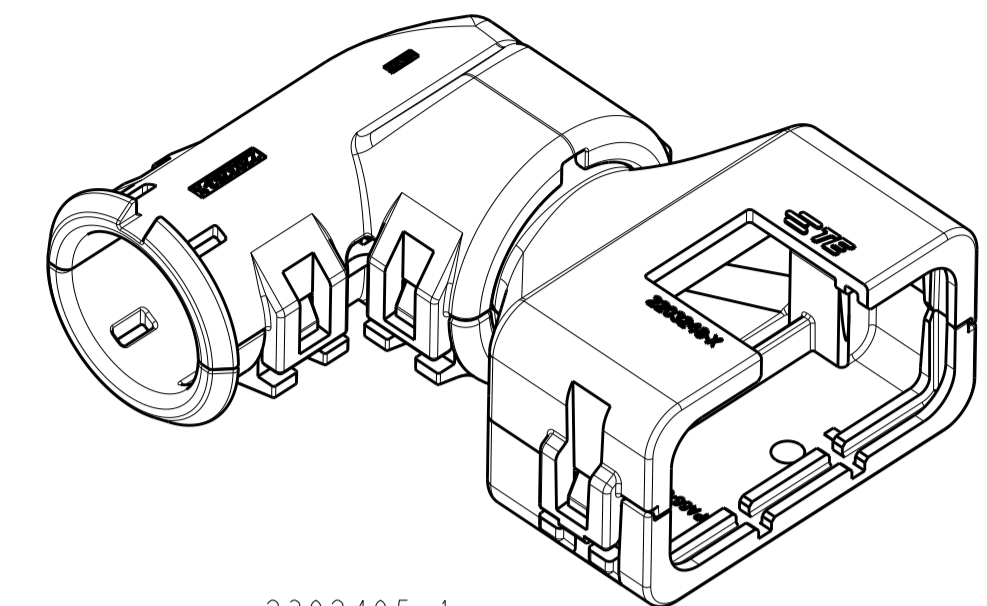

2302495-1  
ASSEMBLED ISOMETRIC VIEW SHOWN

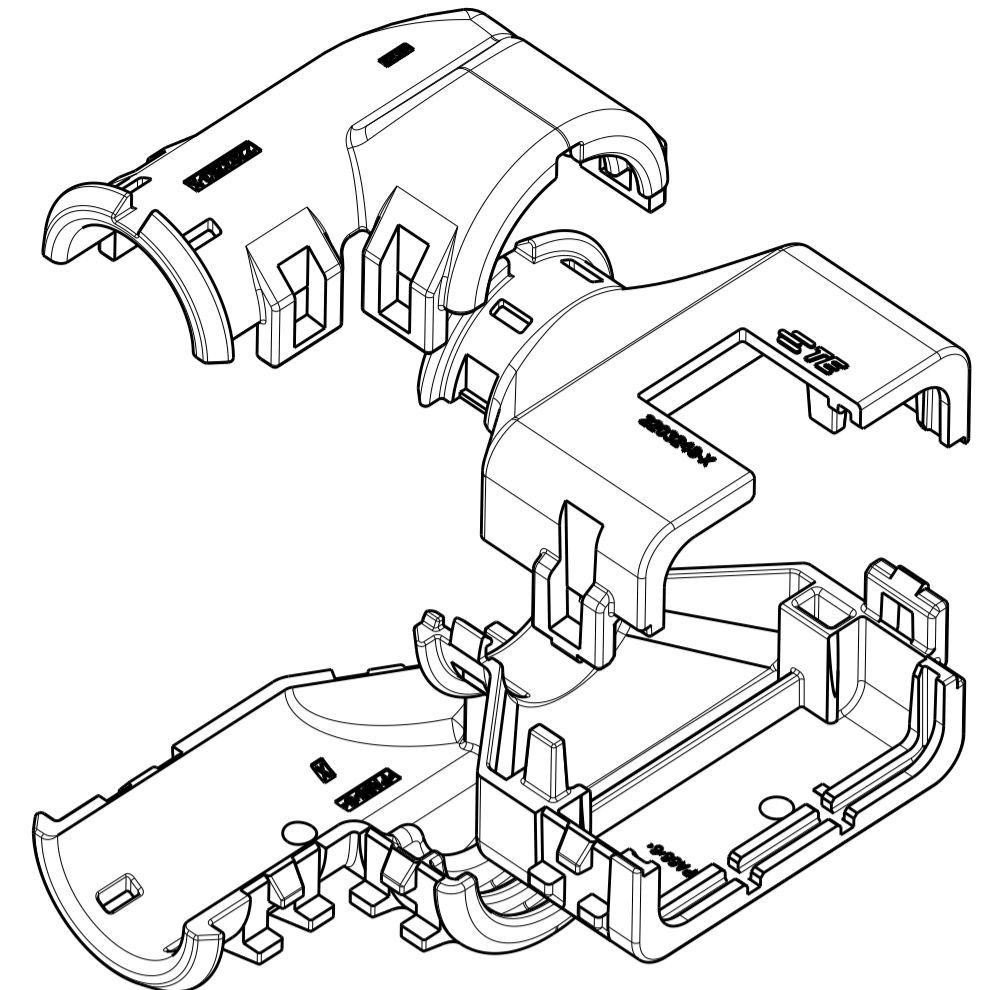

2302495-1  
EXPLODED ISOMETRIC VIEW SHOWN

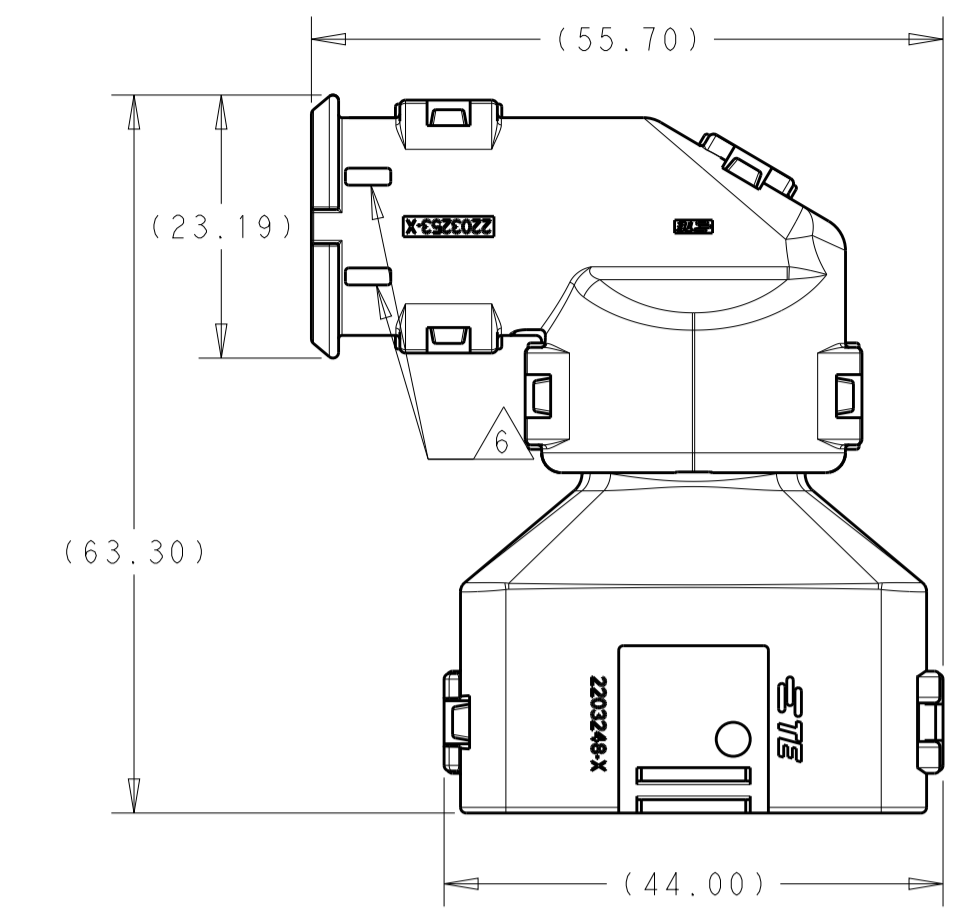

- 1 MATERIAL: NYLON MOLDING COMPOUND, BLACK, PA66/6.
- 2 BACKSHELL DESIGNED SUCH THAT TWO HALVES ATTACH TO ONE ANOTHER AND CLAMP AROUND THE CONNECTOR COVER.
- 3 ELBOW DESIGNED SUCH THAT TWO HALVES ATTACH TO ONE ANOTHER AND CLAMP AROUND THE BACKSHELL COLLAR.
- 4 DIMENSIONS TO BE MEASURED WHEN ELBOWS AND BACKSHELLS ASSEMBLED.
- 5 PRODUCT WEIGHTS:  
 2302495-1: 15.05g ASSEMBLED  
 2302495-2: 15.50g ASSEMBLED  
 2302495-3: 15.25g ASSEMBLED
- 6 4MM WIDE SLOTS FOR TIE WRAP TO SECURE HARNESS WIRES (-1 ONLY).
- 7 HEAT SHRINK TUBING FEATURE (-1 AND -3 ONLY).
- 8. INSTRUCTION SHEET: 408-151043.
- 9. CONDUIT PROFILE: NORMAL ONLY.

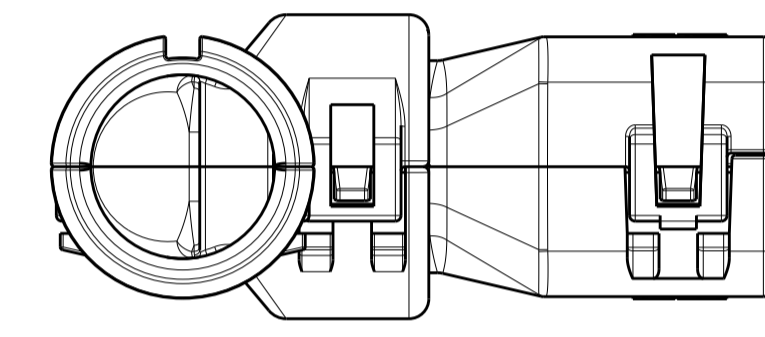

2302495-1  
ASSEMBLED VIEW SHOWN  
DIMENSIONS SHOWN TYPICAL FOR 2302495-1 AND -3

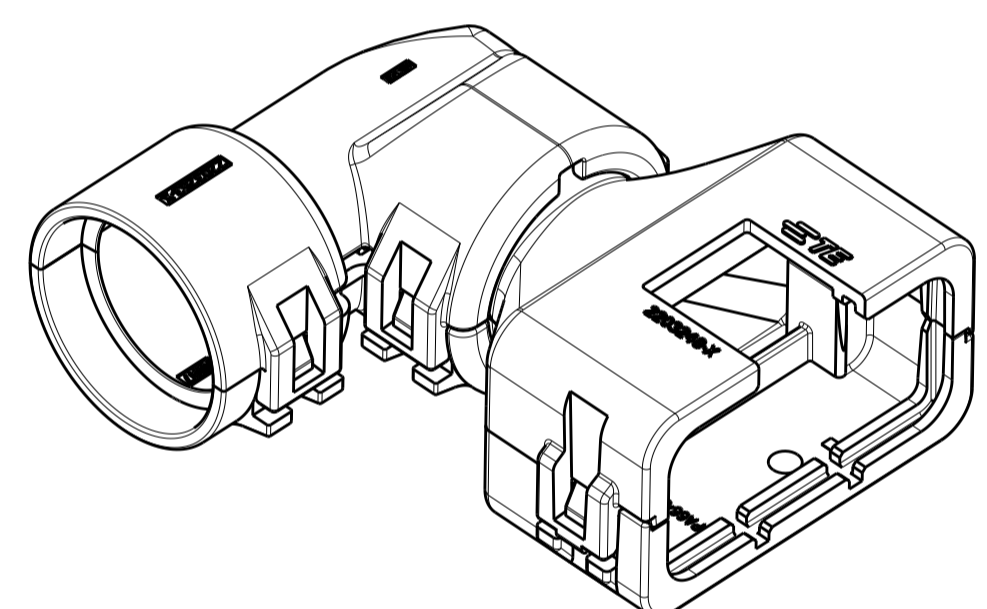
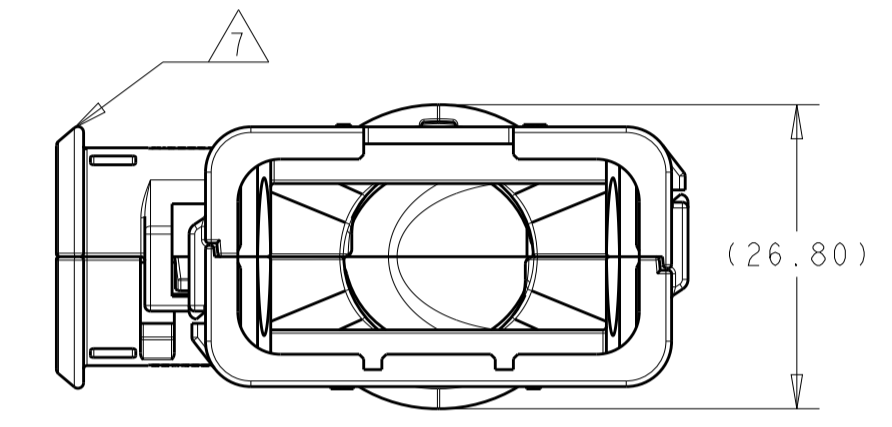

2302495-2  
ASSEMBLED ISOMETRIC VIEW SHOWN

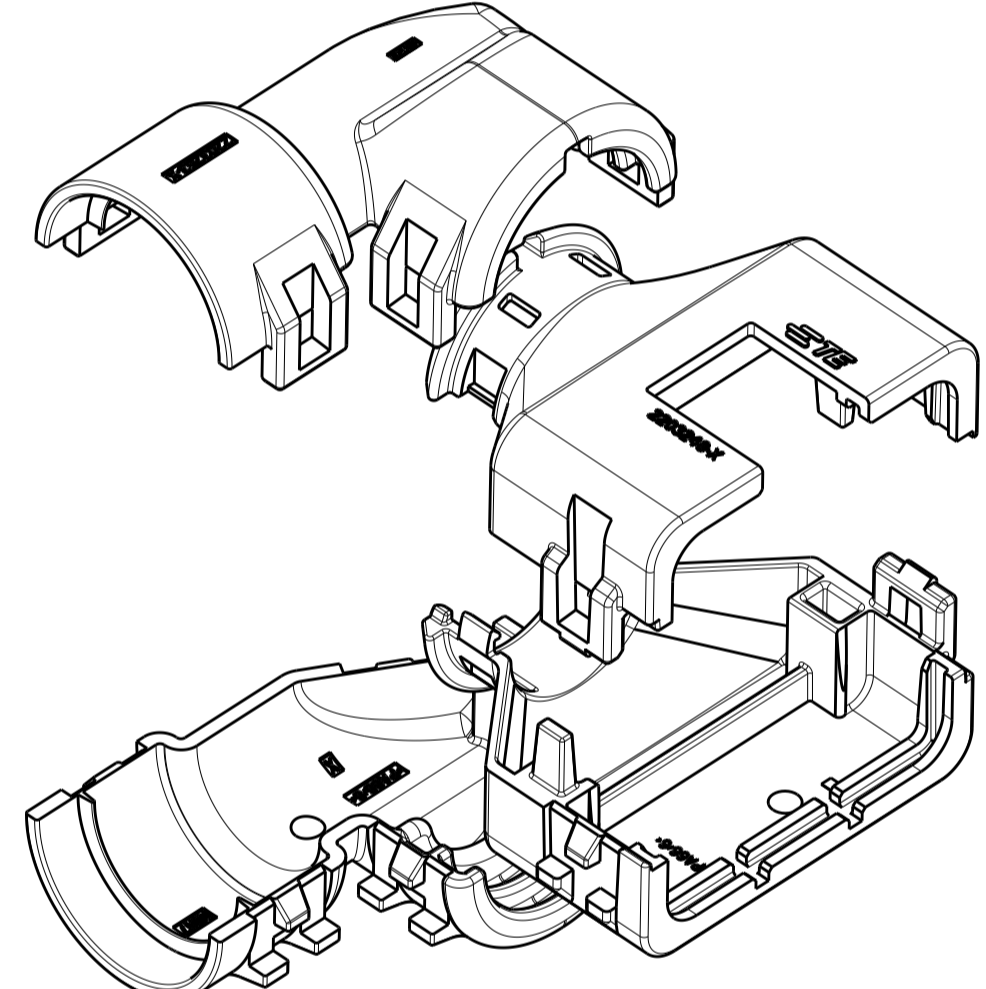

2302495-2  
EXPLODED ISOMETRIC VIEW SHOWN

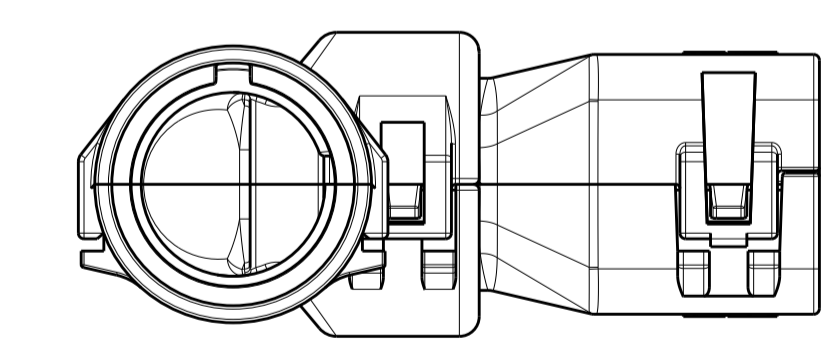
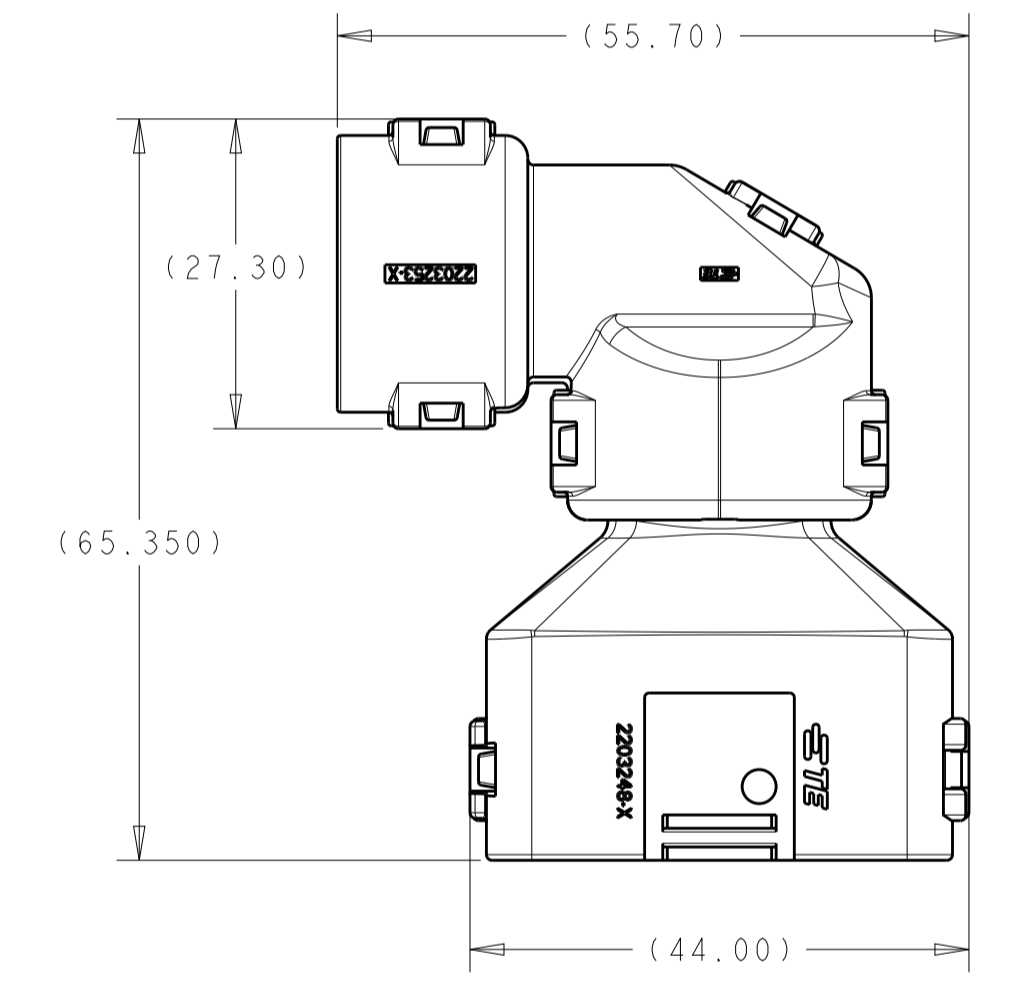

2302495-2  
ASSEMBLED VIEW SHOWN  
DIMENSIONS SHOWN FOR 2302495-2 ONLY

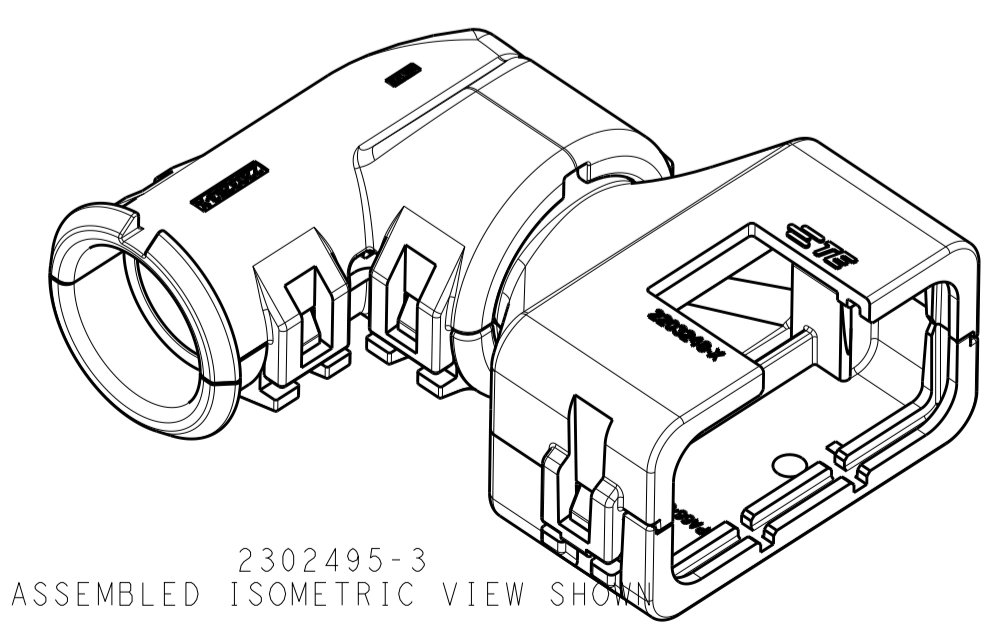
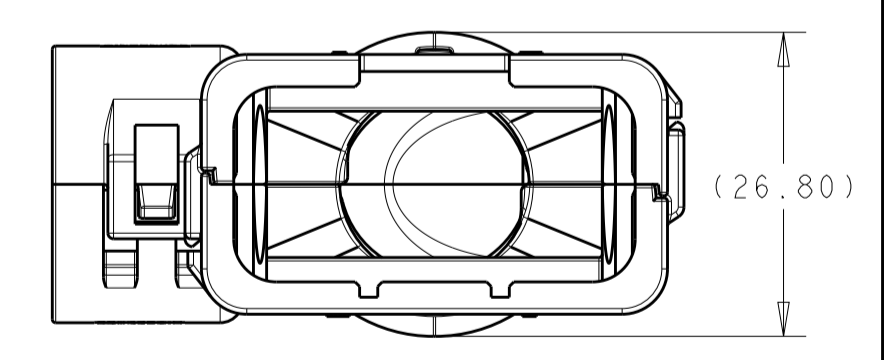

2302495-3  
ASSEMBLED ISOMETRIC VIEW SHOWN

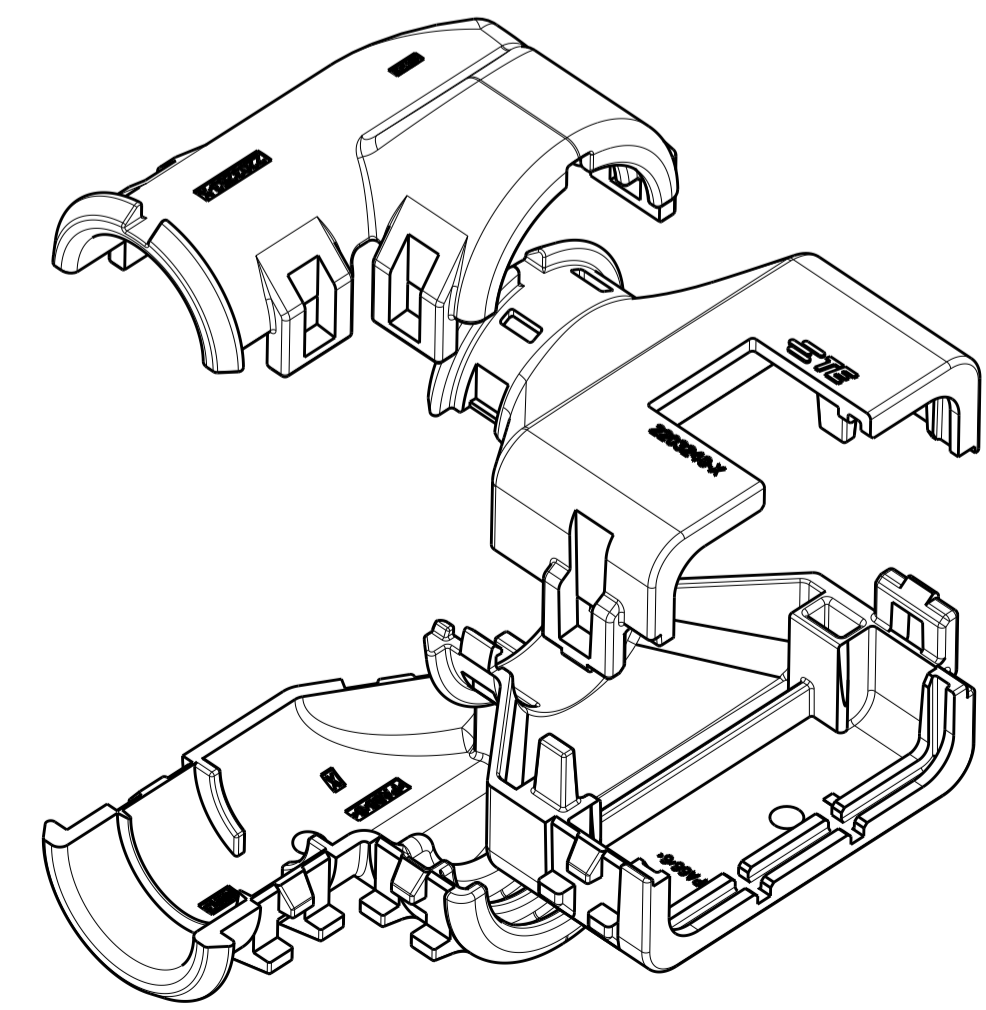

2302495-3  
EXPLODED ISOMETRIC VIEW SHOWN

776437-X	NC16	NW13	2302495-3
776533-X	NC20	NW17	2302495-2
	SMOOTH	SMOOTH	2302495-1
FITS ON PLUG ASSY	CORREGATE NC	CORREGATE NW	PART NUMBER
	CONDUIT SIZE		

THIS DRAWING IS A CONTROLLED DOCUMENT.		DWN J MCNEAL 13APR2016		
DIMENSIONS: mm [INCHES]		CHK R BALTER 13APR2016		
TOLERANCES UNLESS OTHERWISE SPECIFIED:		APVD R BALTER 13APR2016	NAME BACKSHELL AND ELBOW KIT, 12 POSN PLUG ASSY, AMPSEAL 16	
0 PLC ±		PRODUCT SPEC	-	
1 PLC ±		APPLICATION SPEC	108-151043	
2 PLC ±		SIZE	A1	
3 PLC ±		CAGE CODE	00779	
4 PLC ±		DRAWING NO	C=2302495	
ANGLES ±		RESTRICTED TO	-	
FINISH		WEIGHT	5	
MATERIAL		CUSTOMER DRAWING	SCALE 3:2 SHEET 1 OF 1 REV A2	