



Chipsmall Limited consists of a professional team with an average of over 10 year of expertise in the distribution of electronic components. Based in Hongkong, we have already established firm and mutual-benefit business relationships with customers from,Europe,America and south Asia,supplying obsolete and hard-to-find components to meet their specific needs.

With the principle of “Quality Parts,Customers Priority,Honest Operation,and Considerate Service”,our business mainly focus on the distribution of electronic components. Line cards we deal with include Microchip,ALPS,ROHM,Xilinx,Pulse,ON,Everlight and Freescale. Main products comprise IC,Modules,Potentiometer,IC Socket,Relay,Connector.Our parts cover such applications as commercial,industrial, and automotives areas.

We are looking forward to setting up business relationship with you and hope to provide you with the best service and solution. Let us make a better world for our industry!



Contact us

Tel: +86-755-8981 8866 Fax: +86-755-8427 6832

Email & Skype: info@chipsmall.com Web: www.chipsmall.com

Address: A1208, Overseas Decoration Building, #122 Zhenhua RD., Futian, Shenzhen, China



THIS DRAWING IS UNPUBLISHED. RELEASED FOR PUBLICATION 20
 © COPYRIGHT 20 BY - ALL RIGHTS RESERVED.

REVISIONS				
P	LTR	DESCRIPTION	DATE	APVD
	A	REVISED PER ECO-17-010648	21JUL2017	RK DD

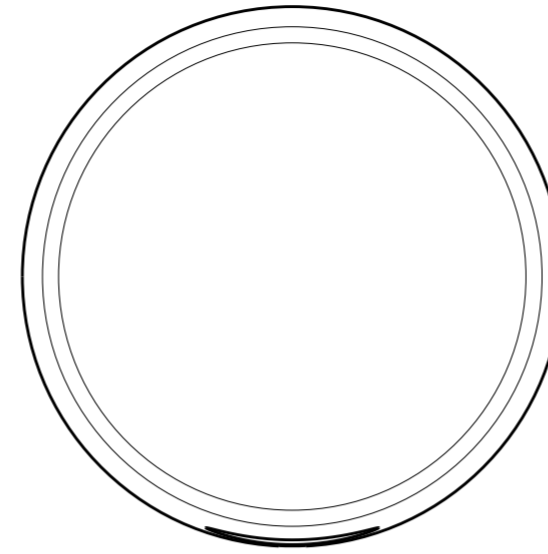
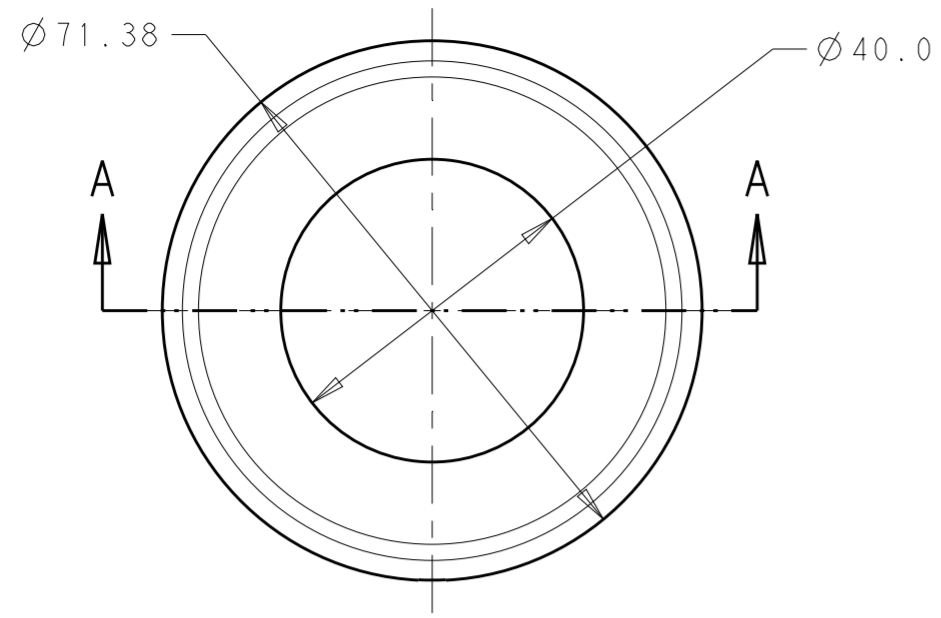

NOTES:

- 1 MATERIAL: PBT
- 2 MATING LIGHT CONTROLLER BASE ASSEMBLY TE P/N 2213871-1 AND 1-2213871-1.
- 3. THIS PRODUCT HAS NOT COMPLETED VALIDATION TESTING
- 4 DELETED
- 5 DOME P/N: 2306129-1 OR 1-2306129-1 TO BE USED WITH SLEEVE P/N: 2306133.
- 6 MAX ALLOWABLE PCB DIAMETER= Ø66.625

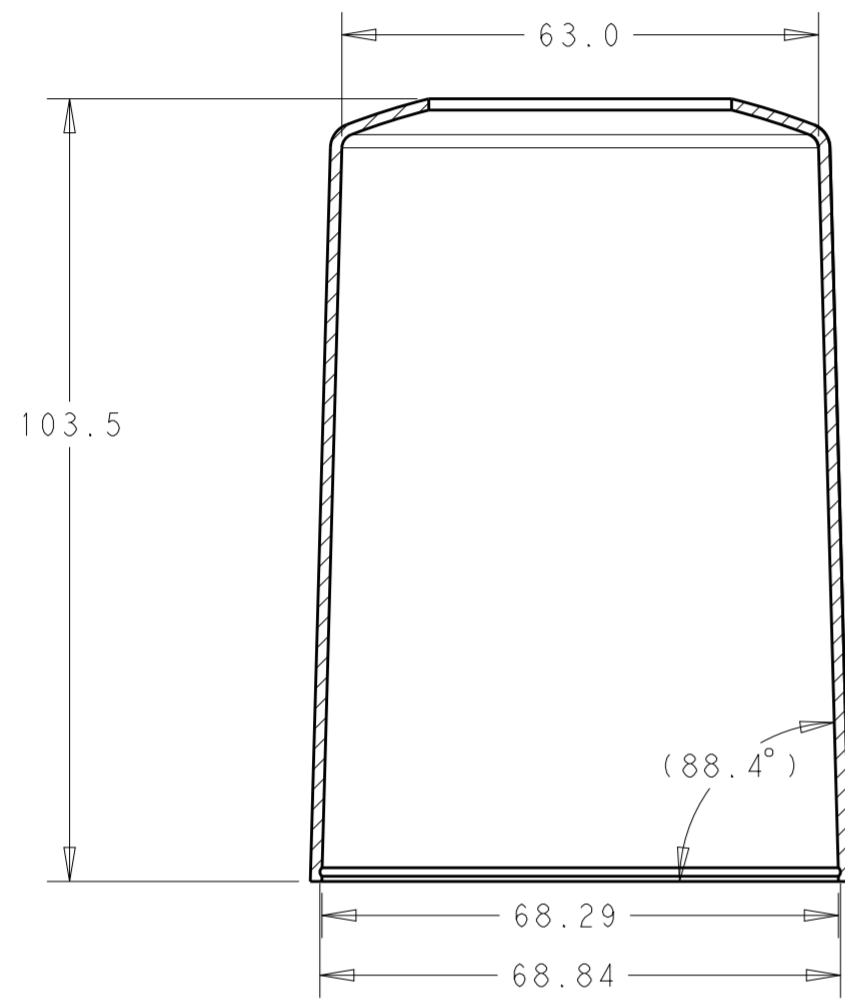

SECTION A-A

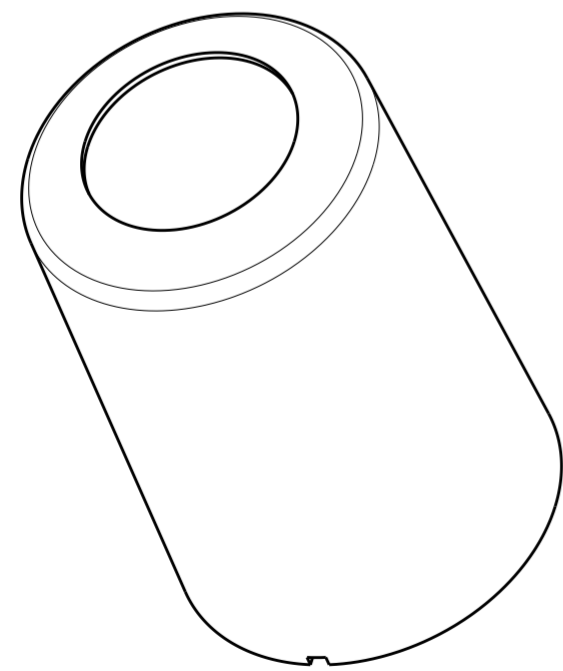
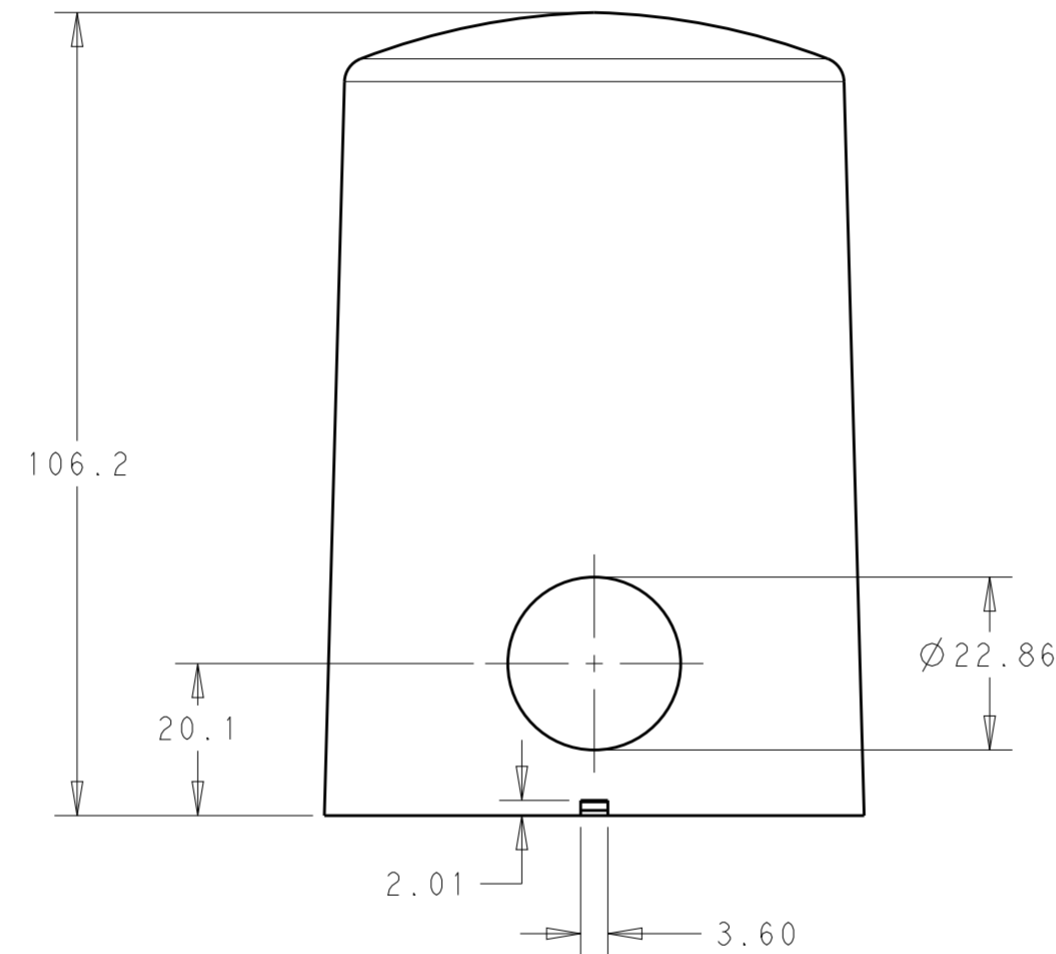

1-2306133-1
SHOWN

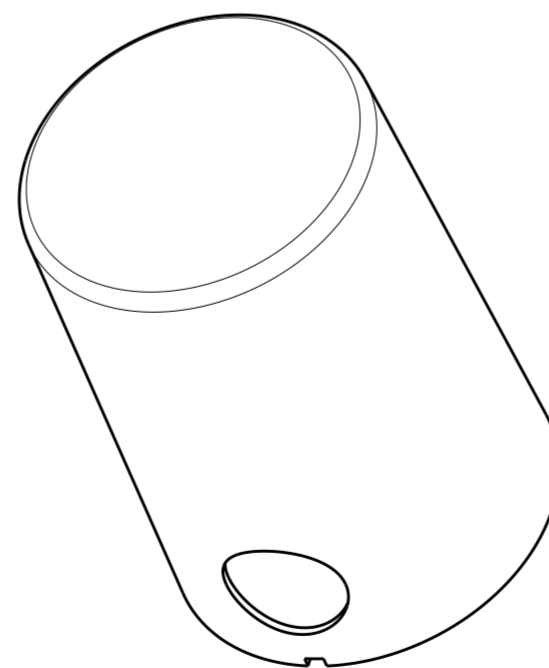

2306133-1
SHOWN

TOP HOLE	JET BLACK	1-2306133-1
SIDE HOLE	JET BLACK	2306133-1
DESCRIPTION	COLOR	PART NO.

THIS DRAWING IS A CONTROLLED DOCUMENT.		DWN J. SHAFFER 18JUL2016	APVD - 18JUL2016		TE Connectivity
DIMENSIONS: mm		CHK E. HOWARD 18JUL2016	NAME SLEEVE, CONTROLLER, LIGHT BASE, TALL, 76 DIA		
TOLERANCES UNLESS OTHERWISE SPECIFIED:		PRODUCT SPEC 108-32125	SIZE A2		RESTRICTED TO -
0 PLC ±		APPLICATION SPEC 114-32159	CAGE CODE -		DRAWING NO. C-2306133
1 PLC ±0.3		WEIGHT -	SCALE 1:1		SHEET 1 OF 2
2 PLC ±0.25		CUSTOMER DRAWING	REV A		
3 PLC ±					
4 PLC ±					
ANGLES ±					
FINISH -					
MATERIAL 1					

THIS DRAWING IS UNPUBLISHED. RELEASED FOR PUBLICATION 20
 © COPYRIGHT 20 BY - ALL RIGHTS RESERVED.

REVISIONS				
P	LTR	DESCRIPTION	DATE	APVD
-	-	SEE SHEET 1	-	-

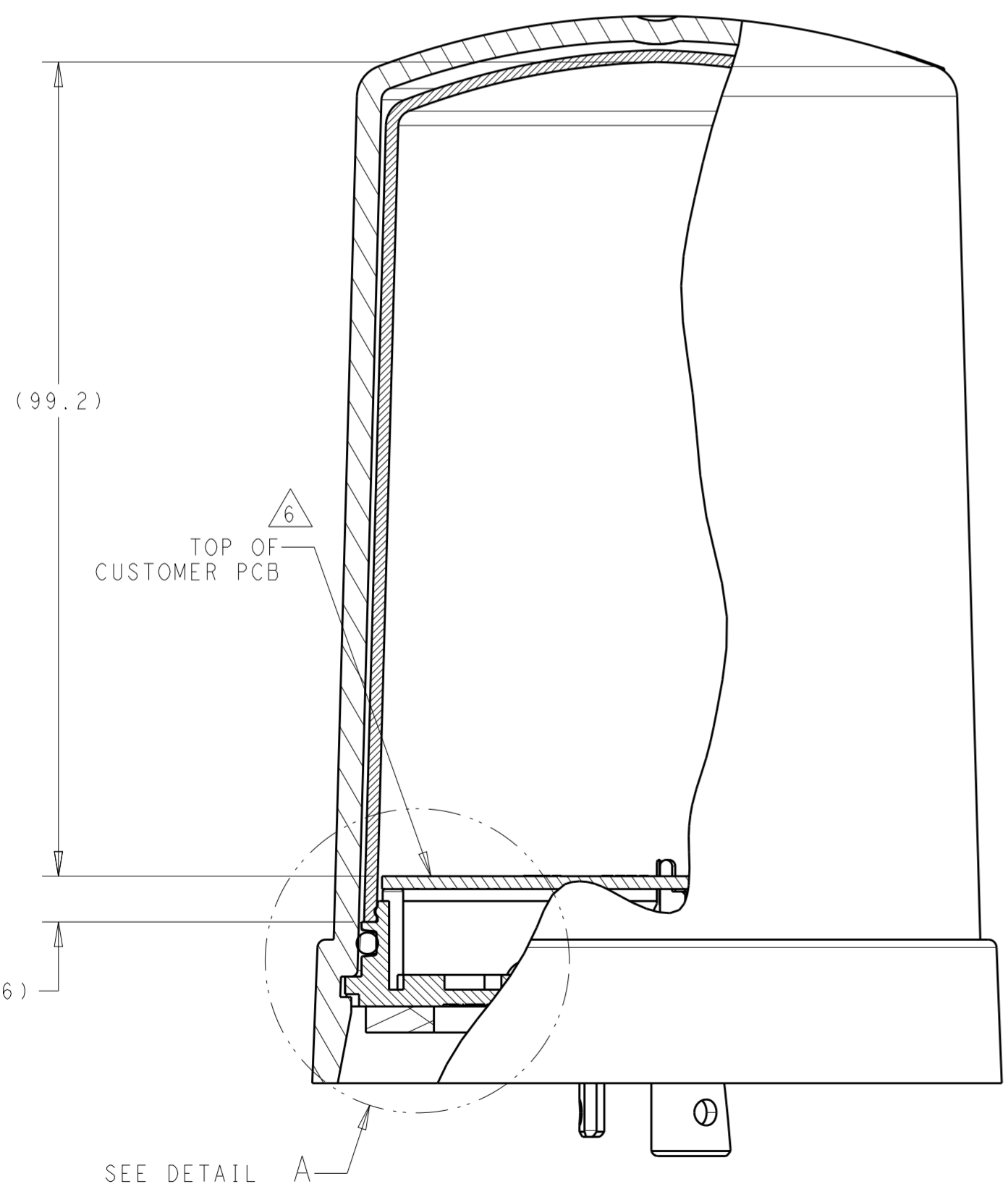
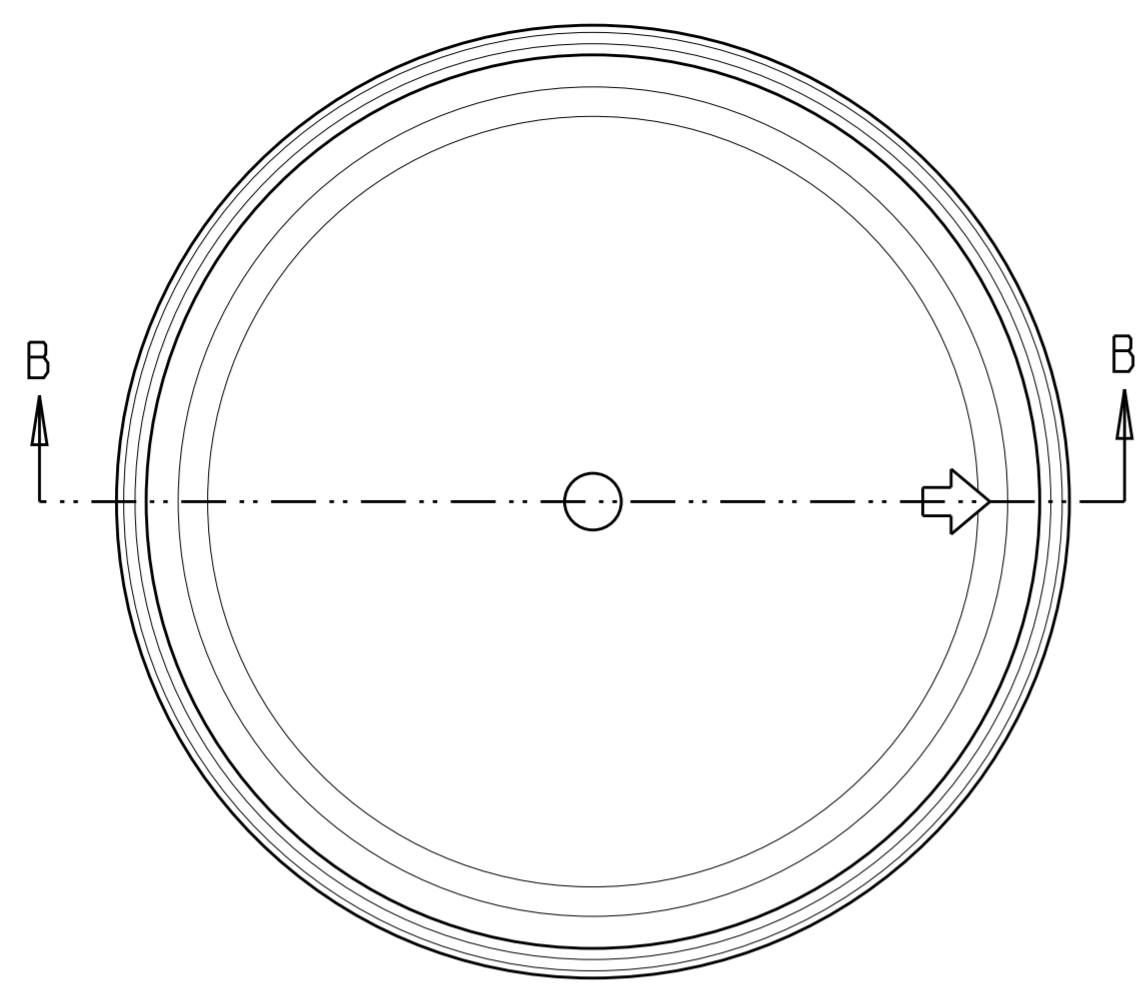

SECTION B-B
SCALE 3:2

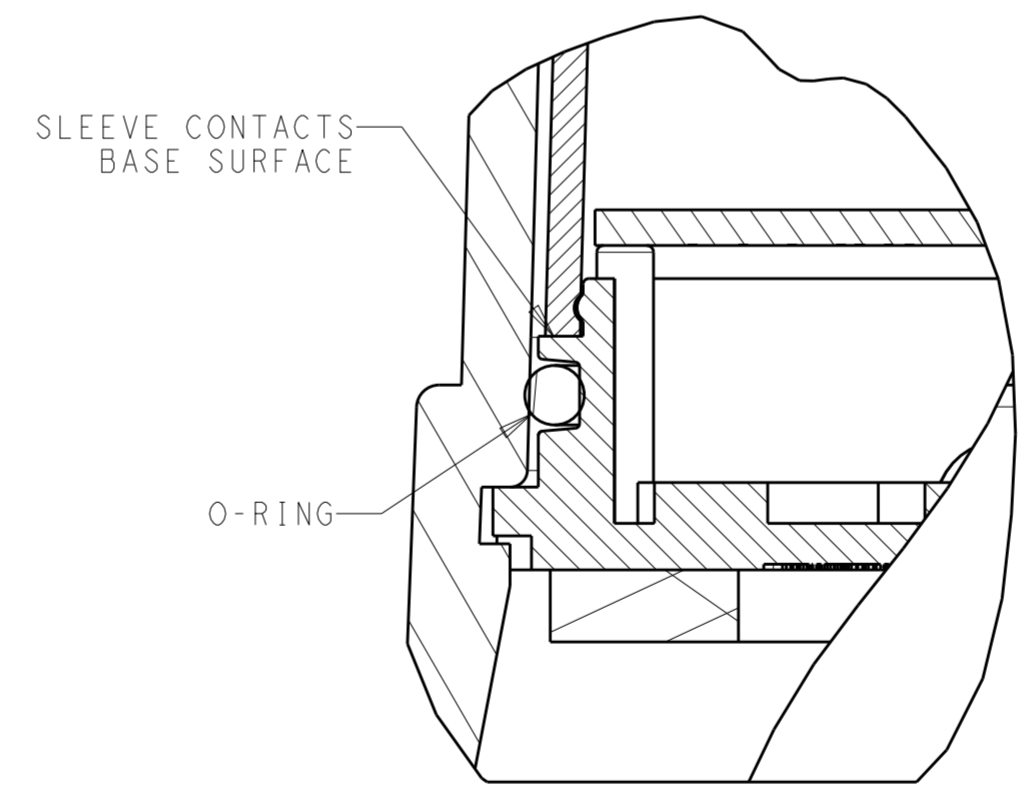
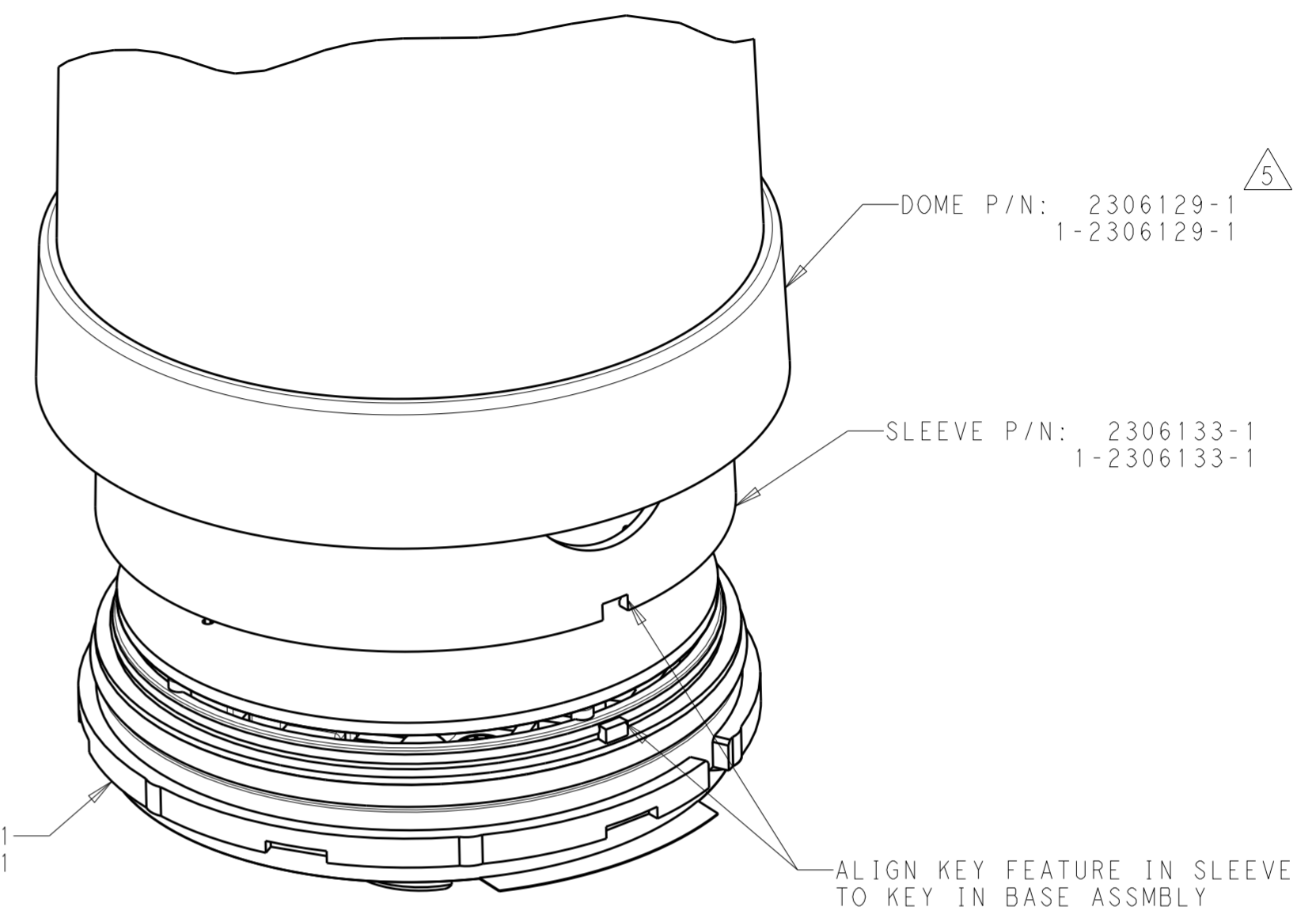

THIS DRAWING IS A CONTROLLED DOCUMENT.		DWN J. SHAFFER 18 JUL 2016	TE Connectivity	
		CHK E. HOWARD 18 JUL 2016		
DIMENSIONS: mm		APVD -		NAME SLEEVE, CONTROLLER, LIGHT BASE, TALL, 76 DIA
TOLERANCES UNLESS OTHERWISE SPECIFIED: 0 PLC ± 1 PLC ±0.3 2 PLC ±0.25 3 PLC ± 4 PLC ±		PRODUCT SPEC 108-32125		SIZE A2
MATERIAL		APPLICATION SPEC 114-32159		CAGE CODE -
FINISH		WEIGHT -		DRAWING NO C-2306133
		CUSTOMER DRAWING		RESTRICTED TO -
		SCALE 1:1		SHEET 2 OF 2
				REV A