



Chipsmall Limited consists of a professional team with an average of over 10 year of expertise in the distribution of electronic components. Based in Hongkong, we have already established firm and mutual-benefit business relationships with customers from,Europe,America and south Asia,supplying obsolete and hard-to-find components to meet their specific needs.

With the principle of “Quality Parts,Customers Priority,Honest Operation,and Considerate Service”,our business mainly focus on the distribution of electronic components. Line cards we deal with include Microchip,ALPS,ROHM,Xilinx,Pulse,ON,Everlight and Freescale. Main products comprise IC,Modules,Potentiometer,IC Socket,Relay,Connector.Our parts cover such applications as commercial,industrial, and automotives areas.

We are looking forward to setting up business relationship with you and hope to provide you with the best service and solution. Let us make a better world for our industry!



Contact us

Tel: +86-755-8981 8866 Fax: +86-755-8427 6832

Email & Skype: info@chipsmall.com Web: www.chipsmall.com

Address: A1208, Overseas Decoration Building, #122 Zhenhua RD., Futian, Shenzhen, China



LUMAWISE Endurance N Enhanced Base

**NOTE**

All numerical values are in metric units [with U.S. customary units in brackets]. Dimensions are in millimeters [and inches]. Unless otherwise specified, dimensions have a tolerance of ± 0.13 [$\pm .005$] and angles have a tolerance of $\pm 2^\circ$. Figures and illustrations are for identification only and are not drawn to scale.

**DANGER****ELECTRIC SHOCK HAZARD**

This LUMAWISE Endurance N Enhanced Base (LENEB) is not touch safe without the cover assembly installed. Never plug in the assembly without the cover snapped into position.



Failure to observe this warning could result in severe injury or death.

**CAUTION**

— Do not perform any service or maintenance other than as described in this specification. Injury or damage to the tool may result.

**ATTENTION**

— Observe precautions for handling electrostatic sensitive devices.

Failure to observe these precautions may result in injury or property damage.

Document Sections

1. Introduction.....	Page 1
2. Architecture Detail.....	Page 5
3. Electrical Design Guidance.....	Page 9
4. Mechanical Design Guidance.....	Page 13

1 Introduction

The TE Connectivity LUMAWISE Endurance N Enhanced Base creates a platform for development and manufacture of NEMA/ANSI C136 street and outdoor lighting control solutions. The Enhanced Base leverages the TE Connectivity Light Controller Base Assembly and adds AC power switching and low voltage DC power outputs necessary to enable control node solutions, allowing designers to focus on control and communication features.

1.1 Applications

The Lumawise Endurance N Enhanced Base (LENEB) is suitable for control of luminaires using the ANSI/NEMA C136-style photocontrol receptacle. The LENEb offers zero-cross switching to manage the high-inrush current of LED luminaires and also supports other lighting technologies. The wide-range AC voltage input, multiple output DC voltages and control signal capabilities of the LENEb also make it well suited to Smart City and Smart Grid applications:

- Street and roadway lighting control
- Commercial & campus outdoor lighting management
- Smart City control networks
- Smart Grid to Smart Cities bridging

1.2 Solution Overview

Figure 1 shows the defined regions in a control node design using the LENEb. This diagram and the terminology in Table 1 are used throughout this document to describe functionality, capabilities and design practice.

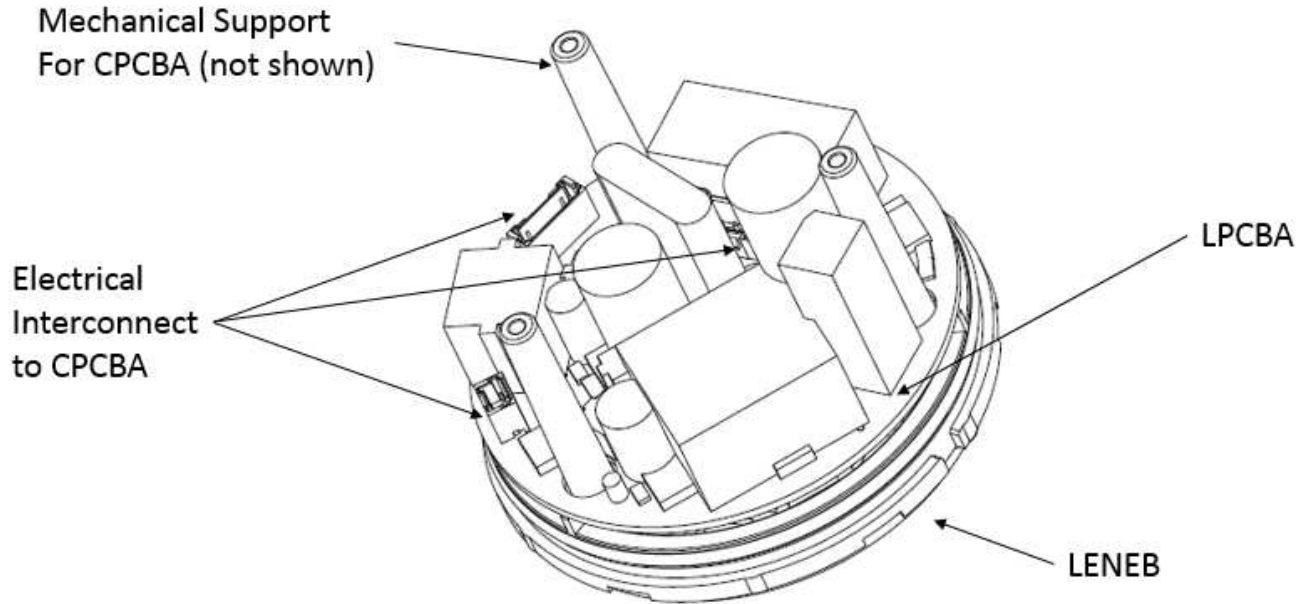

Figure 1. Control Node Layout using the LENEb

1.3 Terminology

Table 1. Terminology

Term/Acronym	Meaning
ANSI	American National Standards Institute
CPCBA	Customer Printed Circuit Board Assembly. The PCBA designed by the customer that directly mounts to the LENEb.
Control Node	The complete end product of an LENEb development comprising the LENEb, CPCBA and any other customer circuitry, and a cover.
Customer Solution Area	Also called the customer area, the customer solution area is the virtual space comprising the CPCBA and any other customer circuitry, connected to the LPCBA by the LENEb mechanical support and electrical interconnect.
DALI	Digital Addressable Lighting Interface
Electrical Interconnect	Electrical interconnect in the LENEb refers to the Customer Signal Area Connector supporting power and control signals between the LPCBA and CPCBA, and the Energy Metering Connector supporting energy metering signals from the LPCBA to a customer energy metering implementation.
FELV	Functional Extra-Low Voltage
LENEb	Acronym for the Lumawise Endurance N Enhanced Base. The solution which this datasheet describes.
LPCBA	LENEb Printed Circuit Board Assembly. The electronic board at of the LENEb.
Mechanical Support	Mechanical support in the LENEb refers to the integrated standoffs that support the CPCBA above the LPCBA.
NEMA	National Electrical Manufacturers Association

PCBA	Printed Circuit Board Assembly. A PCBA comprises a printed circuit board (PCB) and all of the installed components to create a functional assembly.
Physical Base	The mechanical platform onto which the LPCBA is mounted, including the ANSI C136 electrical connector. Essentially the same as TE Connectivity's Light Controller Base Assembly product but with added mechanical support.

1.4 Reference Material

- Revision Summary

Update section 2.6 and 3.6.

- Customer Assistance

Reference Product Base Part Number 2314786 and Product Code L937 are representative of the LENEb. Use of these numbers will identify the product line and help to locate product and tooling information when visiting www.te.com or calling the product information number.

- Drawings

Customer drawings for product part numbers are available from www.te.com. Information contained in the customer drawing takes priority.

- Specifications

The product is designed per ANSI C136.41-2013, see Product Specification 108-133085 for a full list of specifications and product performance and test results.

1.5 Storage

- Shelf Life

The product should remain in the shipping containers until ready for use to prevent deformation to components. The product should be used on a first in, first out basis to avoid storage contamination that could adversely affect performance.

- Chemical Exposure

Do not store product near any chemical listed below as they may cause stress corrosion cracking in the material.

Alkalis	Ammonia	Citrates	Phosphates	Citrates	Sulfur Compounds
Amines	Carbonates	Nitrites	Sulfur Nitrites		Tartrates

1.6 Handling

The LENEb assembly is supplied with the interfacial gasket unassembled; therefore, take precautions not to damage or lose the gasket prior to assembly. Dimming brush contacts are preinstalled in their correct position, therefore, take precautions to not bend or damage the dimming brush contacts during subsequent assembly operations.

1.7 Cleaning



CAUTION

— Cleaning products that can erode the plastic parts of the Base must not be used. Oils or lubricants of any type other than mentioned in this document must not be used on or around the Base. Note that the relay used on the LENEb is not sealed and must not be immersed in a cleaning solution.

1.8 Functional Element Overview

Figure 2 shows a block diagram of the functional blocks of the LENEb printed circuit board assembly (LPCBA) interconnected to the physical base and showing signaling to the customer solution area. Figure 3 shows the pinout of the various connections to the LENEb. The following sections overview the capability of each block. More detailed description, where applicable, can be found in the following sections.

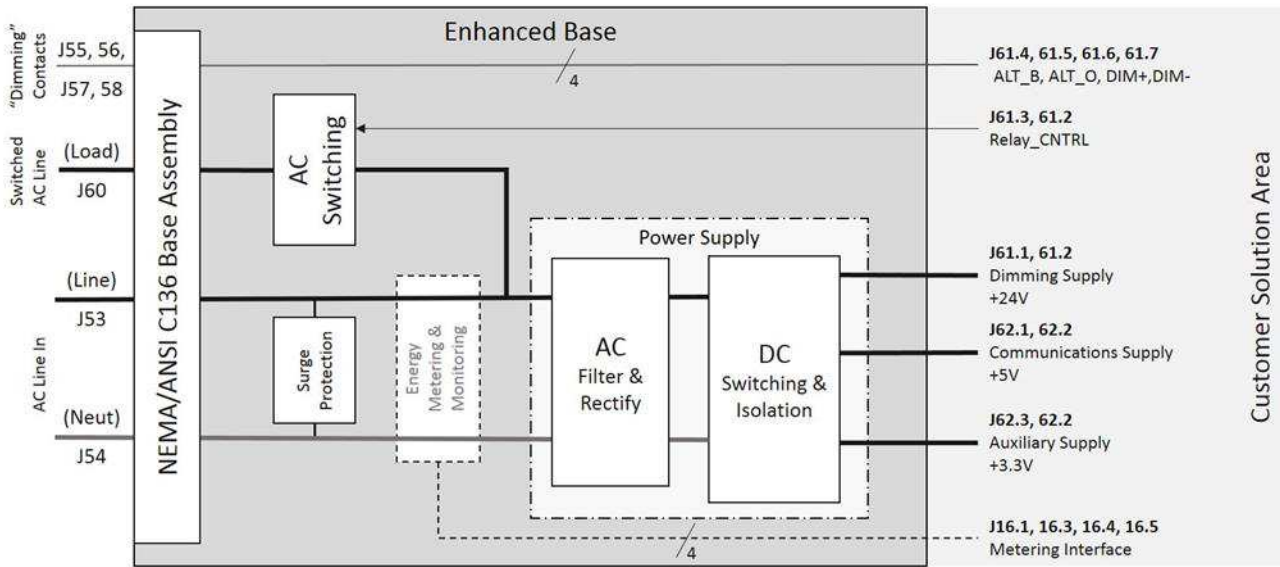

Figure 2. LENEb Functional Block Diagram

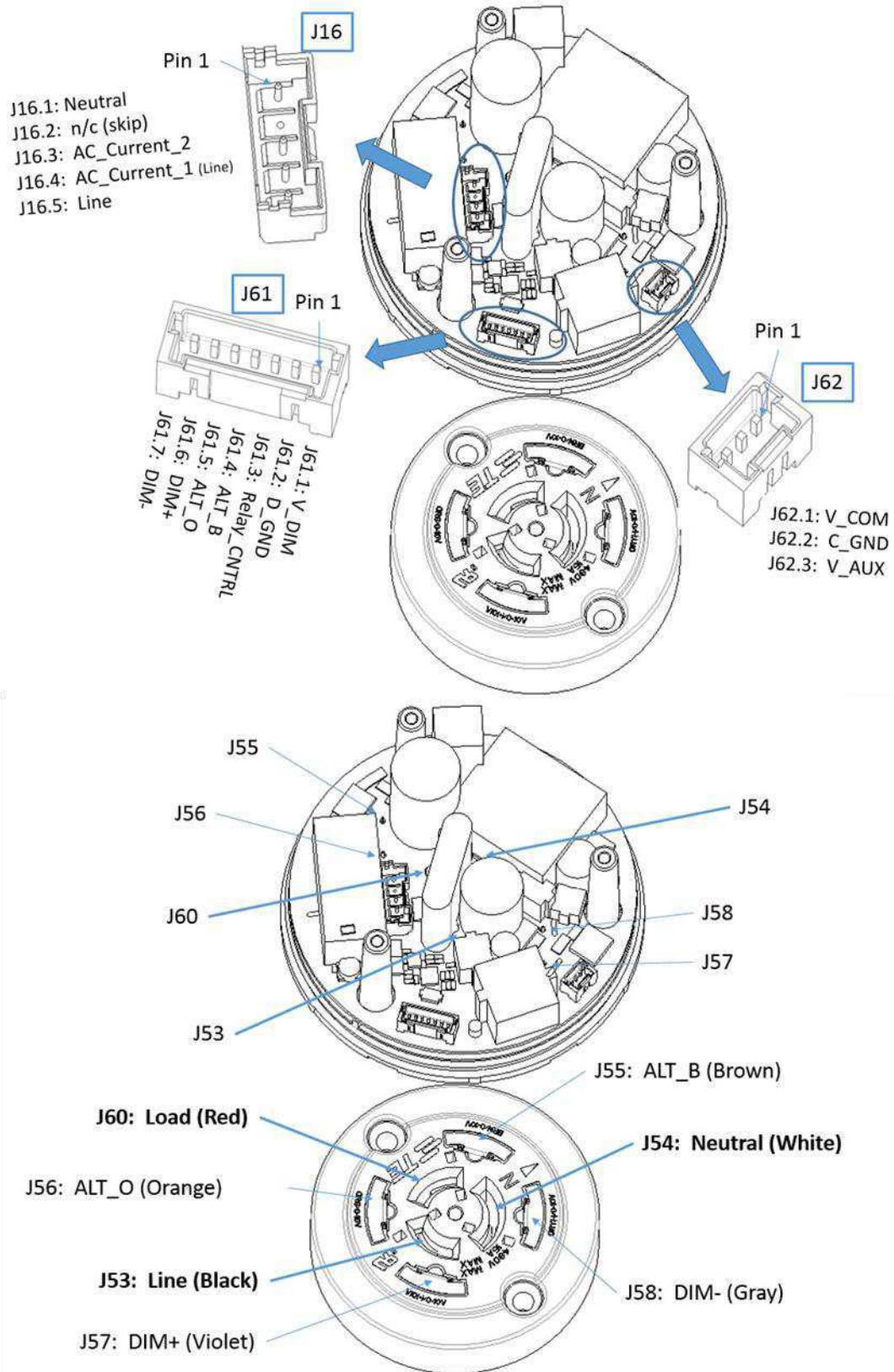

Figure 3. Enhanced Base Pinout / Contact Arrangement

1.9 Power Supply Input

The LENEb supports input voltages and switching of loads for street and outdoor lighting systems having nominal supply voltages of 110 VAC to 277 VAC, and 50/60 Hz.

1.10 AC (Luminaire) Switching

The Lighting Control LENEb can switch the input AC line voltage up to 10A resistive or 5A electronic ballast. A digital control line from the Customer Area actuates the line switching relay, and zero-cross circuitry ensures that switching occurs as the sinusoidal AC voltage is nearby the zero-volt threshold, limiting inrush current to the luminaire.

1.11 Mechanical Support

The LENEb provides the mechanical structure to which the customer control board attaches via M3 or #4 thread forming fasteners to the three provided screw bosses. This structure supports the electrical interconnect that is the customer area interface from the LENEb PCBA and provides the platform for the customer control node to address ANSI C136.31 (and other) vibration and shock requirements.

2 Architecture Detail

Figure 4 provides a detailed block diagram of the LENEb to provide deeper architectural and operational understanding of functional elements needed for control node development.

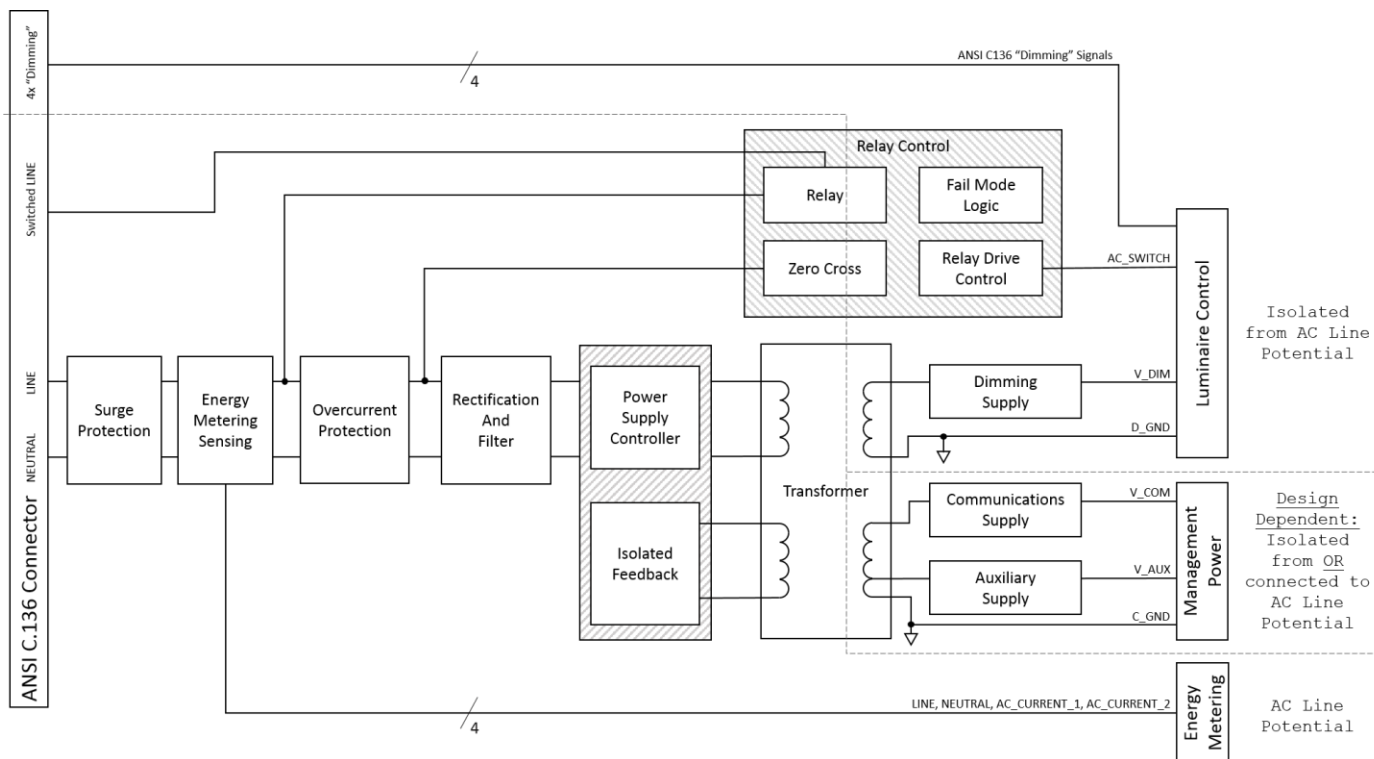

Figure 4. Detailed Block Diagram of LENEb

2.1 ANSI C136 Connector

The LENEb is built on TE Connectivity’s ANSI C136-compliant Light Controller Base Assembly. The connector supports all 4 low voltage “dimming” contacts which are connected to the LPCBA, maintaining electrical isolation, and routed directly to the customer solution area via the Luminaire Control connector.

2.2 Surge Protection

The LENEb provides ANSI C62.41 6kV, 3kA combination wave surge protection. Surge protection comprises a 10kV, 10kA metal oxide varistor (MOV). The MOV is connected between the input AC LINE and NEUTRAL directly adjacent to physical base connector contacts on the LPCBA.

2.3 Energy Metering Inputs

An optional interface can be provided in the LENEb for energy metering and monitoring. The energy usage of a control node and AC switched load may be metered through this interface. Energy metering support circuitry is located on the non-protected (ANSI C136 connector) side of the line overcurrent protection to enable proper metering even in the presence of high inrush current to the load. The inputs for energy metering include a direct connection to AC LINE and NEUTRAL as well as a 2.5 mΩ shunt resistor, which is connected on the line side of the AC input. When implementing energy metering, pay special attention to circuit referencing, as described in Electrical Design Guidance, to maintain FELV as required in IEC 61347-1 for DALI and 0-10V dimming.

2.4 Line Overcurrent Protection

The LENEb contains a UL1412-compliant resistor to protect the control node from excessive current. The line input protection targets the LENEb power supply and end product control node, but does not protect the switched load (luminaire) or energy metering. It is required that the luminaire is fused or otherwise protected by the branch circuit interrupter.

2.5 Relay

The TE Connectivity relay is built for inrush current applications, specifically LED lighting systems and filament/incandescent lamp loads. The relay supports up to 10A resistive or 5A electronics ballast and is optimized and tested per UL 508 for lighting applications. The relay coil and control is contained within the LENEb, and can be interfaced through the relay drive control.

2.6 Relay Drive Control

The relay drive control (Relay_CNTRL) provides a low power control interface for the relay state. This control interface is referenced to the Dimming Supply common and pulled up to an internal 3.3 VDC supply on the LPCBA through a 1.0 kΩ resistor. The internal pull-up allows for open collector/source transistor control on the CPCBA. When this control line switches states, the input is used in combination with additional logic to drive the relay coil.

Relay_CNTRL	Fail Mode = Fail On	Fail Mode = Fail Off
Low (<0.6V)	Relay Open	Relay Closed
High (>2.0V)	Relay Closed	Relay Open



NOTE

Observe normal ESD practices when connecting to the relay drive control pins to prevent damage to the LENEb.

2.7 Fail Mode

The fail mode of the LENEb relates to the end state of the relay when the supply power is removed from the device. The fail mode is described as being either “fail on” or “fail off,” with the relay to the load (luminaire) being either closed or open, respectively. For example, with a fail on device, the luminaire will remain lighted following a power failure at the LENEb switch (assuming that the luminaire remains powered).

The relay drive control uses input from the zero cross circuitry and RELAY_CNTRL signal, and monitors the Dimming Supply for fail mode response. The circuitry actively changes the relay state to match the factory fail mode setting if the 24 VDC of the Dimming Supply indicates the power supply has failed or power is removed.

2.8 Zero Cross Circuitry

The LENEb uses zero cross circuitry to switch the load as the sinusoidal AC voltage waveform crosses the zero voltage threshold. By switching when the voltage is at or near zero volts, the amount of current that is suddenly switched to the load is reduced or eliminated. This is helpful in preserving the relay's contact life in the LENEb especially with high inrush current loads such as LED lighting.

2.9 Power Supply Controller

The fundamental architecture of the LENEb is based on an isolated flyback switch mode power supply. This architecture provides the isolation for use with DALI and 0-10V dimming, meeting FELV requirements, with the ability to provide multiple DC voltage outputs. The power supply implements a bias winding of the transformer to maintain isolated feedback for the constant voltage outputs. Additionally, the supply supports fault condition detection to provide protection in the event of a shorted output or an open loop condition.

The AC LINE input is rectified to DC voltage and filtered prior to the switching power supply. The filtering has a dual purpose to limit conducted emissions onto the AC input line and it provides bulk energy storage for short term input variations.

2.10 DC Power Outputs

The DC side of the LENEb power supply comprises 3 DC outputs, isolated from the AC input through an isolation transformer. The three DC supplies are the Dimming Supply, the Communications Supply and the Auxiliary Supply.

- **Dimming Supply**

The Dimming Supply is targeted to power DALI and 0-10V dimming control circuitry. The voltage of the Dimming Supply is 24VDC +/- 10%, with a 50mA current capacity.

In many cases, designers will regulate the 24 VDC down to common DALI voltages such as 16 VDC. It is also possible for designers to regulate the 24 VDC supply to 10 VDC allowing the LENEb "DALI dimming configuration" to be used for both DALI and 0-10V dimming designs.

The Dimming Supply meets FELV requirements of IEC 61347-1 with respect to the Communications Supply, the Auxiliary supply, and the AC LINE input in the LENEb.

- **Communications Supply**

The Communications Supply is targeted to power wireless communications within a control node, but it may be used as the designer sees fit. The voltage of the Communications Supply is 5 VDC ±10%, with a 1000 mA current capacity. The Communication Supply shares circuit common with the Auxiliary Supply.

- **Auxiliary Supply**

The Auxiliary Supply is targeted to power general processing and sensing within a control node, but it may be used as the designer sees fit. The voltage of the Auxiliary Supply is 3.3 VDC ±10%, with a 500 mA current capacity. The Auxiliary Supply shares circuit common with the Communications Supply.

2.11 Internal Connections

The electrical interconnect of the LENEb is divided into the Luminaire Control connector, Management Power connector, and the Energy Metering connector. The use of connectors and cables enables simple and secure interconnect to a CPCBA.

2.12 Luminaire Control Connector (LCC)

The Luminaire Control connector carries the 4 “dimming” connections from the ANSI C136 physical base, Dimming Supply power and circuit common, and the luminaire switching signal, RELAY_CNTRL on a TE 7 position Mini CT connector. See Table 2 for the LCC pinout. Signals on the Luminaire Control connector are isolated from AC LINE potential and signals on the Management Power Connector.

Table 2. Luminaire Control Connector Signals

Pin	Signal	I/O	Description
1	V_DIM	O	Dimming supply, isolated, 24 VDC.
2	D_GND	O	Dimming supply common. Isolated from other supplies.
3	RELAY_CNTRL	I	Digital control for relay.
4	ALT_B	--	ANSI C136.42 alternate contact (Brown).
5	ALT_O	--	ANSI C136.42 alternate contact (Orange).
6	DIM+	--	ANSI C136.42 dimming contact (Violet).
7	DIM-	--	ANSI C136.42 dimming contact (Gray).

2.13 Management Power Connector (MPC)

The Management Power connector carries the Communications Supply and Auxiliary Supply power and ground signals on a TE 3 position Mini CT connector. See Table 3 for the MPC pinout. Signals on the Management Power Connector may be referenced to AC LINE potential or not, depending on customer design. Refer to Electrical Design Guidance.

Table 3. Management Power Connector Signals

Pin	Signal	I/O	Description
1	V_COM	O	Communications supply. 5 VDC.
2	C_GND	O	Communications/Aux supply common (Return).
3	V_AUX	O	Auxiliary supply. 3.3 VDC.

2.14 Energy Metering Connector (EMC)

The Energy Metering connector is implemented on a TE 5 position EP 2.5 header. See Table 4 for the EMC pinout. The Energy Metering connector uses an open pin positions to achieve electrical isolation between signals/voltages carried on the connector.

Table 4. Energy Metering Signals

Pin	Signal	I/O	Description
1	NEUTRAL	O	Direct connect to input NEUTRAL
2	N/C	--	No connect, no pin installed for electrical isolation
3	AC_CURRENT_2	O	LENEB side of 2.5 mΩ current measurement shunt
4	AC_CURRENT_1	O	LINE side of 2.5 mΩ current measurement shunt
5	LINE	O	Direct connect to input Line

3 Electrical Design Guidance

3.1 Electrical Isolation

The DC outputs of the LENEb are isolated from the AC input through an isolation transformer to meet the FELV for DALI and 0-10V dimming, per IEC 61347-1. Additionally, the Dimming Supply output is generated from a separate transformer winding to maintain isolation with the Communications and Auxiliary supplies. The Dimming Supply is isolated in this manner to provide a method for powering an energy metering solution, via the Communications or Auxiliary Supply, which would be electrically coupled to the AC LINE input. Based on this, there are two LENEb topologies to consider for relay control: LENEb without Energy Metering, and LENEb with Energy Metering.

3.2 LENEb without Energy Metering

When Energy Metering is not implemented within the LENEb, the Communications Supply and Auxiliary Supply will not be referenced/electrically coupled to the AC LINE input. In this case, the circuit common of the Dimming Supply and the Communications and Auxiliary supplies may be electrically connected on the CPCBA. Electrically connecting these circuit commons maintains the FELV requirements with the AC input and allows for simplified luminaire and relay control; eliminating the need for opto-couplers or other isolated controls between the Dimming Supply and Communications and Auxiliary Supplies. Figure 5 shows the simple example of customer luminaire control logic, with C_GND and D_GND tied together because energy metering is not implemented, driving the output "Relay_CNTRL" signal which is the direct input to the RELAY_CNTRL input on the LPCBA.

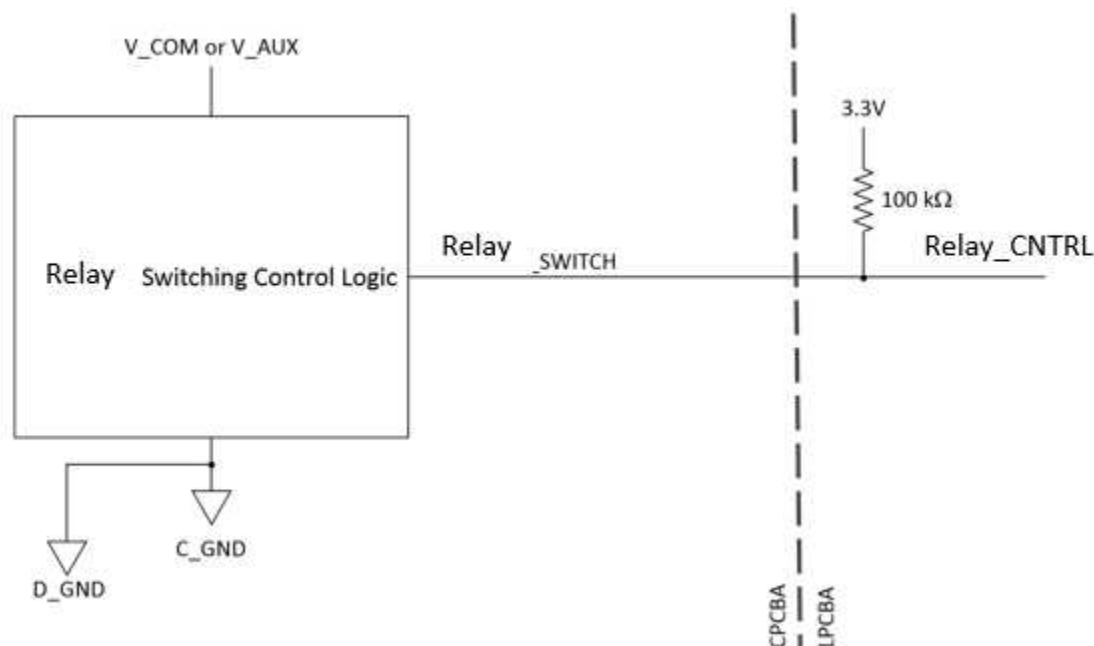
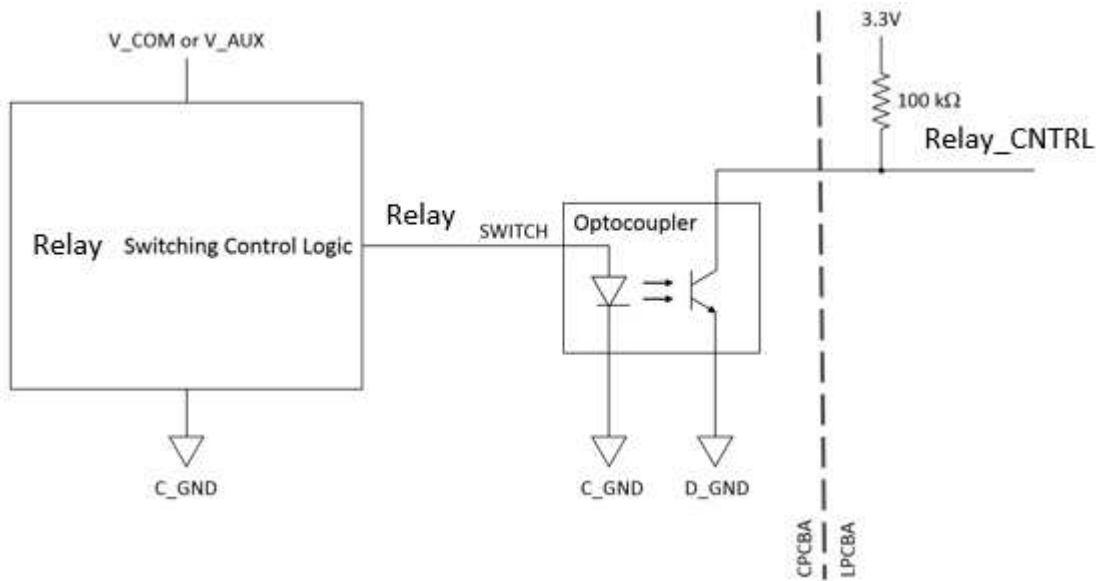

Figure 5, Relay Switching without Energy Metering (Example)

3.3 LENEb with Energy Metering

Implementing Energy Metering with the LENEb requires that the Communications and Auxiliary supplies to be electrically coupled to the AC line. This results in the requirement to keep the Dimming Supply and the Communications and Auxiliary supplies isolated to maintain FELV for the DALI and 0-10V dimming. Optocouplers, or other isolated communication techniques, must be used between logic/microcontrollers, powered by the Communications/Auxiliary Supply, and the Relay Control and DALI/0-10V dimming. Figure 6 shows an example circuit using an optocoupler to isolate between customer relay control logic and the RELAY_CNTRL input on the LPCBA. The optocoupler serves to isolate the CPCBA logic power (V_COM or V_AUX) from the Dimming supply to maintain FELV.

Care should also be taken in dimming circuit design to maintain electrical isolation of the DIM+ and DIM- signals from the CPCBA logic power (V_COM or V_AUX) for FELV. TE has not conducted additional research into optocoupler selection, since it is highly application specific, can include digital vs analog signals, current transfer ratio requirements, and any number of other technical considerations that are customer specific.



3.4 Energy Metering Design Guidance

Energy metering can be implemented through the connections of the energy metering interface, which supplies direct, unaltered, access to AC line voltage and AC current through a 2.5 mΩ shunt resistor. Power metering circuitry must access power (Communications Supply or Auxiliary Supply) via the Customer Solution Area to ensure that FELV requirements of the Dimming Supply are maintained (see Electrical Isolation). Additionally, the shunt resistor connection should remain as short as possible to reduce the potential for signal interference on the current measurement.

3.5 0-10V Dimming Guidance

The 24V output has been designed to support DALI implementation, but also supports 0-10V dimming solutions.

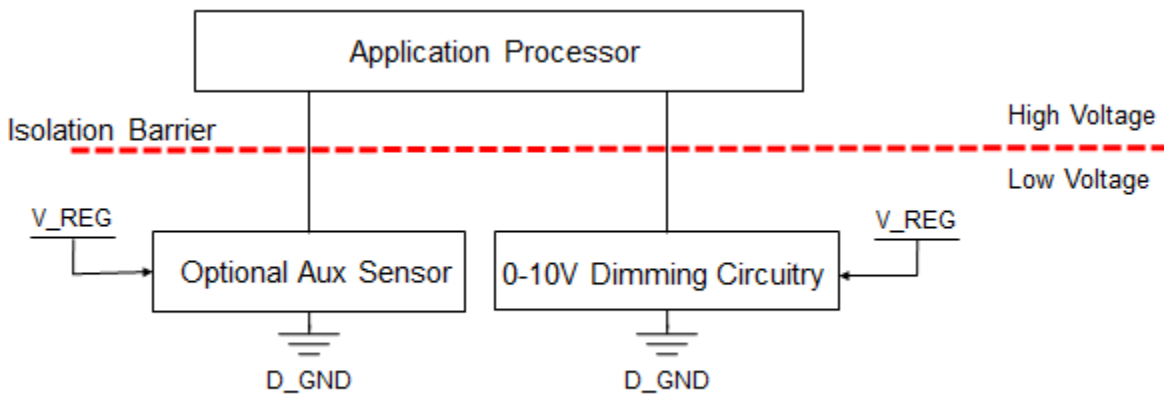

3.6 DALI Guidance

The LENEb is designed to function only as a power supply to the DALI bus, and does not contain any logic to support DALI other than from a hardware power supply perspective.

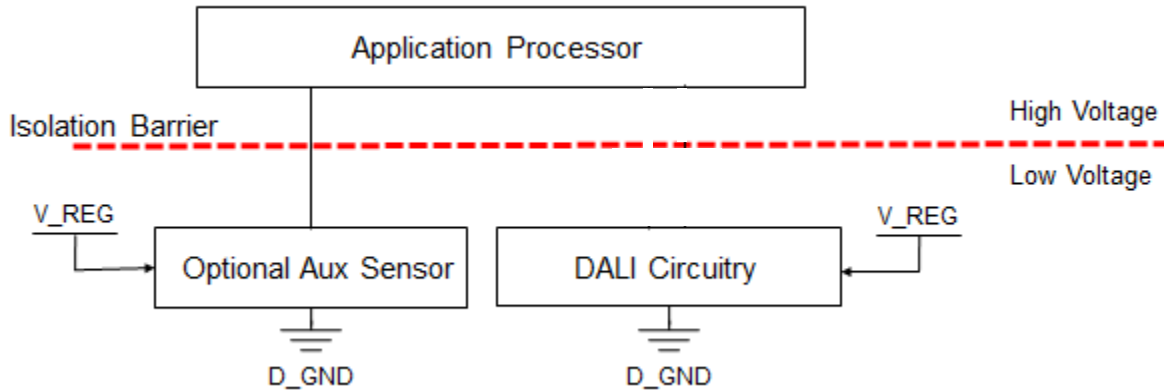

Isolation – See block diagram below for typical interface with the LENEb. For voltage divider values R1 (generally 3 or 4 resistors in series) and R2, please consult the datasheet and/or application note for your selected Energy Monitoring IC for input signal tolerances.

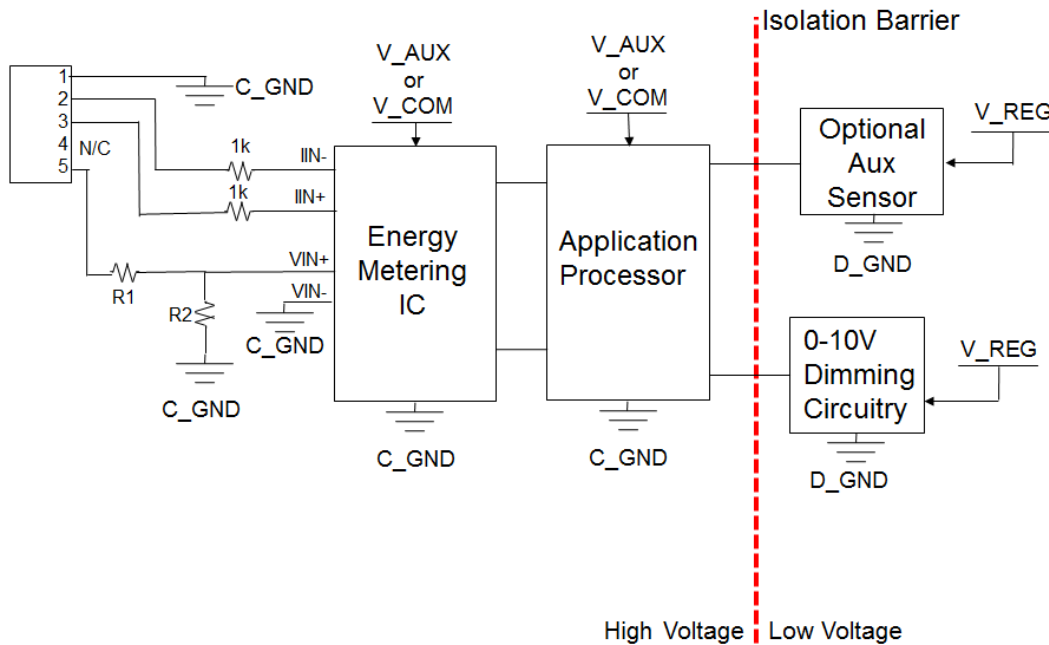

3.7 Maximum Load Current Design Guidance

TE Connectivity's relays are specifically designed for inrush that is typical of switching associated lighting systems. The relay used on the LENEb has been tested to meet UL 508 for various loads including resistive,

Tungsten, magnetic ballasts, and electronic ballasts. The UL 508-based contact ratings of the relay vary with each ballast type. Please consult the RTS3TF24 datasheet on te.com for UL 508 contact ratings.

[RTS3TF24 Datasheet](#)

3.8 Zero Cross Implementation

Zero cross switching is implemented to reduce current inrush, improving product longevity. While optimal benefit in relay life is achieved by exact zero cross switching, switching close to the zero cross provides significant benefit in reducing inrush current versus random switching, which may occur at peak voltage, creating peak current inrush. The zero cross circuit is driven by three inputs: AC Line (frequency), Relay_CNTRL (input from Customer Area), and Timing Calibration.

Timing Calibration is tuned during manufacturing to a fixed timing based on the desired nominal frequency (50 Hz or 60 Hz). Figure 7 shows the topology used to accomplish the zero cross switching of the relay.

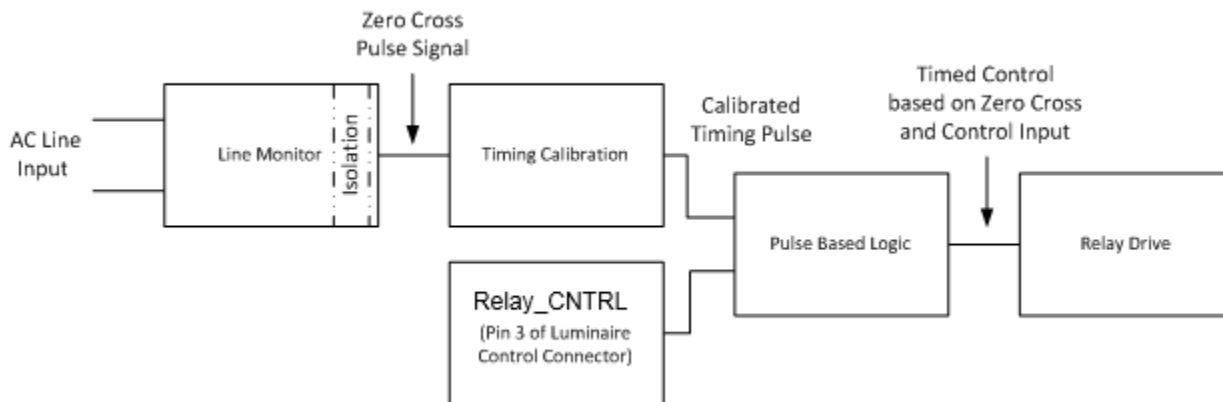

Figure 7: Zero Cross Block Diagram

The AC Line input and Line Monitor are used to establish the exact time of a zero cross event, creating an isolated zero cross pulse signal. This pulse signal is then input to the Timing Calibration circuit which is calibrated to adjust for the relay switching time variation of each individual product. The Calibrated Timing Pulse is used to capture the state of the Relay_CNTRL, input from the Customer Area, in the Pulse Based Logic block and drive the relay state at the zero cross of the AC Line. The relay has a bi-stable latch architecture and the zero cross circuit is calibrated to switch on the make/on sequence of the relay.

3.9 Zero Cross Variation

Due to potential for variations in the line frequency in the field, exact timing for the zero cross can vary. Figure 8 shows the effects of a higher or lower line frequency on the relay switching time. As compared to the nominal line frequency used for calibration, a higher frequency can result in switching after the zero cross and a lower frequency can result in switching prior to the zero cross. For 50 or 60 Hz nominal use, line variation allows for switching up to 2.0ms before or after the zero crossing. Other factors such as LENE loading, AC input line voltage and cycle life of the relay can also affect the zero cross timing.

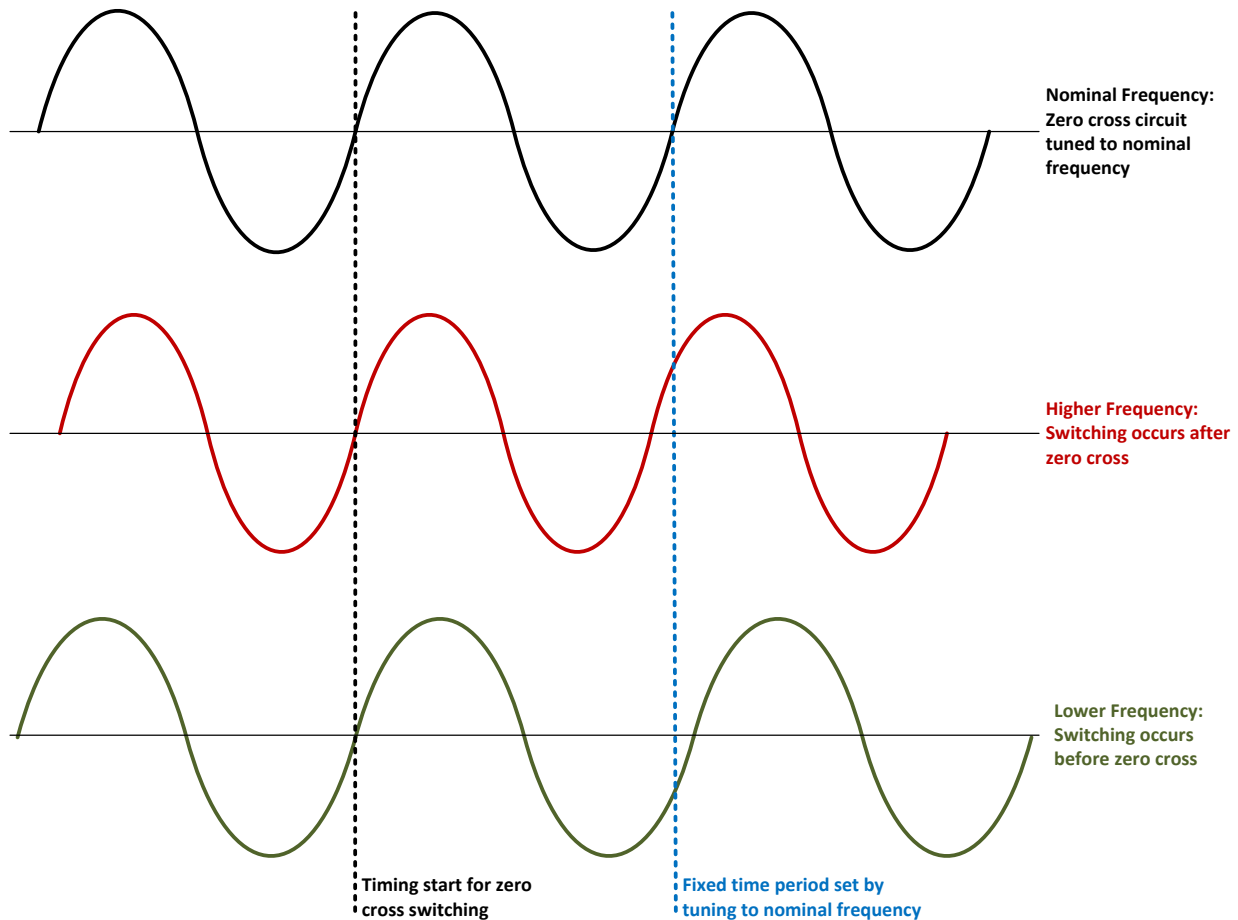

Figure 8: Effects of Line Frequency Variation

3.10 Minimum Load Requirements for Voltage Output Regulation

The voltage supply outputs of the LENEb require a minimum current load to maintain specified voltage regulation. The minimum load requirements are presented in Table 5.

Note that optimal cross regulation among the voltage outputs is best achieved by loading all the outputs with a similar percentage load. When one output is loaded 100% but another is at min load, the output at min load may be out of regulation with the output exceeding 10% over the rated voltage. This can be especially evident if the Communication (5V) output is fully loaded (1000mA) with the other two outputs Auxiliary (3.3V) and Dimming (24V) are at minimum load. Cross regulation for unbalanced output loads will never exceed 20% worst case.

Table 5: Minimum Loads

Voltage Supply	Nominal Voltage (VDC)	Minimum Load (Ω)
Dimming	24	None
Communications	5	120
Auxiliary	3.3	270

4 Mechanical Design Guidance

4.1 Environmental Sealing

The Light Controller Base Assembly on which the LENEb is built is designed for IP66 exposure when properly sealed with an appropriate mating cover. The customer is responsible for the IP rating if the mating cover is not a TE manufactured part.

4.2 Companion Products

TE Connectivity offers a range of products to support street lighting control nodes built with the LENEb. Please visit te.com for more information on these companion products.

- **Cover**

To complete a control node built upon the LENEb, TE Connectivity offers a cover with options for tinting. See TE Customer Drawing 2306130.

- **Dimming receptacle**

TE Connectivity supplies a full line of ANSI C136 compliant dimming receptacles that are matched to the LENEb. Dimming receptacle options include number of dimming contacts, luminaire connection type and a rotatable connector for ease in control node orientation. Please see TE Customer Drawings 2213362 and 2213627 for details.

4.3 Cables and CPCBA Connectors

- **Luminaire Control Connection (LCC) to CPCBA**

LCC from the LPCBA to the CPCBA should be made via TE Mini CT plugs and Headers. The LPCBA is prepopulated with TE Mini CT headers part number 292207-7. TE sells cable assembly 2318043-1 for this connection. See Figure 9. The CPCBA can be populated with TE Mini CT header 292207-7 to mate with the LCC cable assembly. Note that TE has numerous options to mate the Mini CT cable assembly to the CPCBA. These include thru hole/SMT and straight/90 degree Mini CT headers. Please contact TE for assistance. Note: If the customer builds their own cable assemblies, all the wires must be rated 300V or greater.

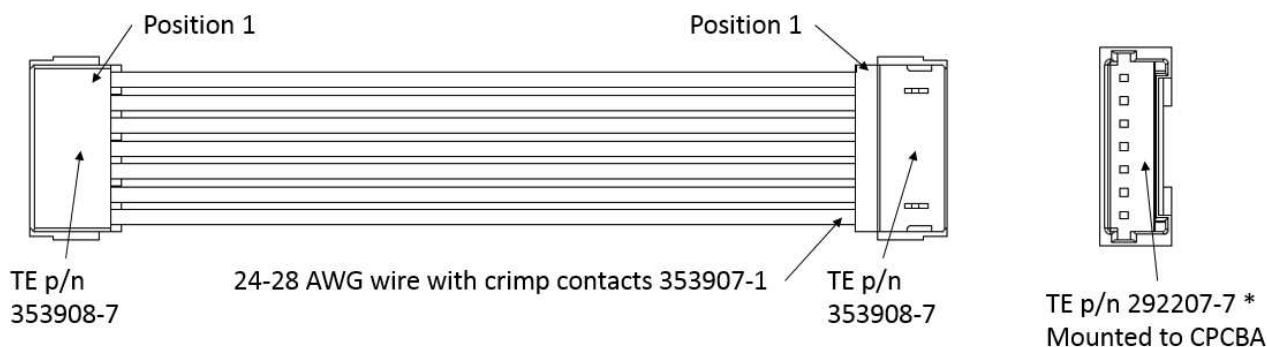

Figure 9. LCC Cable Assembly, TE p/n 2318043-1

- **Management Power Connection (MPC) to CPCBA**

MPC from the LPCBA to the CPCBA should be made via TE Mini CT plugs and Headers. The LPCBA is prepopulated with TE Mini CT headers part number 292207-3. TE sells cable assembly 2318043-2 for this connection. See Figure 10. The CPCBA can be populated with TE Mini CT header 292207-3 to mate with the LCC cable assembly.

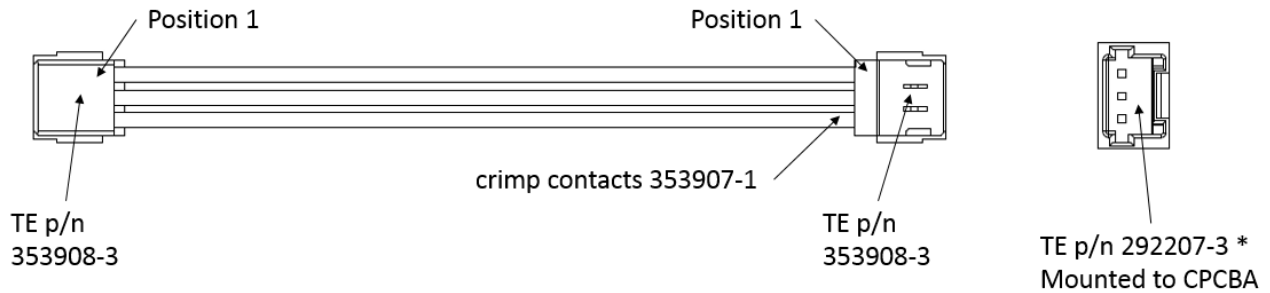

Figure 10. MPC Cable Assembly, TE p/n 2318043-2

- **Energy Metering Connections (EMC) to CPCBA**

If equipped, the Energy Metering Connection from the LPCBA to the CPCBA should be made via TE EP 2.5 plugs and Headers. The LPCBA is prepopulated with a TE 1744418-5 EP 2.5 header. TE sells cable assembly 2318044-1 for this connection. See Figure 11. The CPCBA can be populated with TE EP 2.5 1744418-5 to mate with the EMC cable assembly. Note that TE has numerous options to mate the EP 2.5 cable assembly to the CPCBA. These include straight/90 degree headers. Please contact TE for assistance.

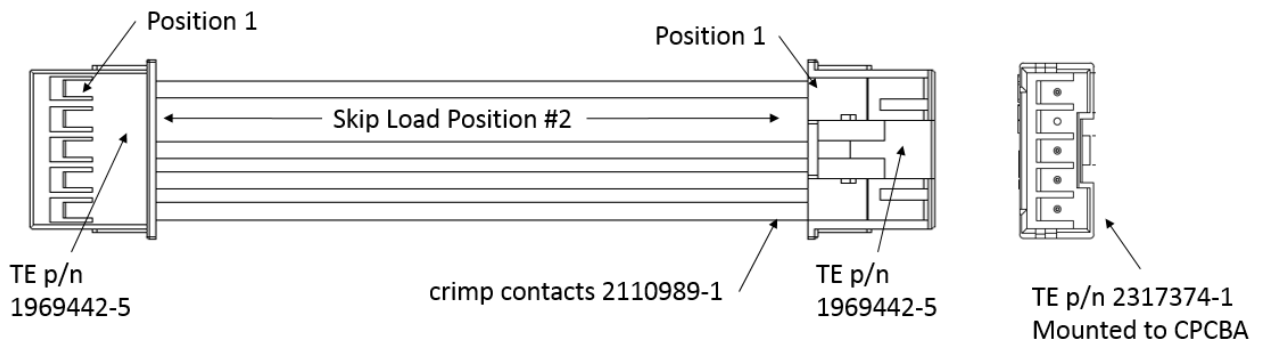

Figure 11. EMC Cable Assembly, TE p/n 2318044-1

4.4 External Mechanicals

The LENEb provides the complete ANSI C136.41 “7 pin” connector for external interface to the luminaire/object of control. The ANSI base provides a seal for ingress protection of the LENEb enclosure. See the Product Drawing for details.

4.5 Mounting CPCBA

The CPCBA is mounted to the LENEb using three M3 or #4 thread forming screws not longer than 10mm (0.4"). It is recommended that the CPCBA incorporate features like a flat to identify the "North" position as shown on TE Customer Print 2314786 to ensure the mounted orientation meets any external sensing requirements (e.g. photocell) and proper component spacing between the CPCBA and LPCBA. The CPCBA should be clocked to the correct position before installing the screws. See Figure 12. The screws should be torqued to no more than 0.1 Nm (16oz-in). The standoffs provide a fixed height above the highest component on the LPCBA for electrical isolation, see the product drawing for details. Should additional height be desired, tubular PCB standoff spacers can be added (with appropriately longer screws).

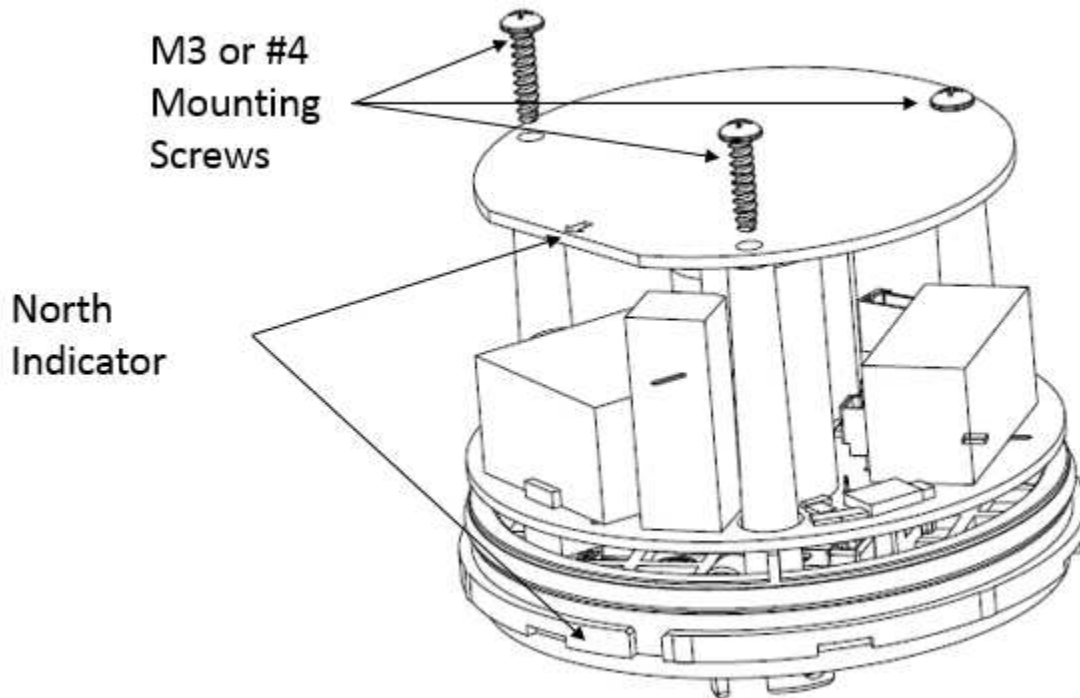

Figure 12. CPCBA mounting

4.6 Cover Assembly

The cover has a raised key which must be properly aligned with a keyway slot on the perimeter of the base. Place the cover onto the base, ensuring the cover key and base keyway are aligned, then press the cover onto the base as shown in Figure 13. An assembly fixture and a small press may be required to assemble the cover to the base. Take precautions not to damage the base assembly and cover during the assembly process. Inspect the cover/base assembly to ensure the three cover latches are fully latched to the base.



Attention: The cover is not designed to be removed once installed

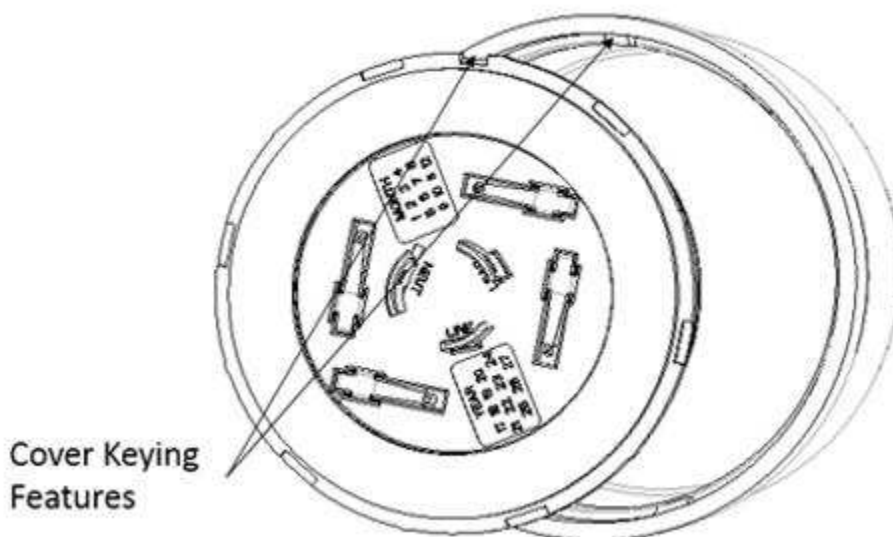

Figure 13. Cover Keying Features

4.7 Interfacial Foam Gasket Assembly to Control Node

To avoid damage to the gasket, it is recommended that gasket assembly is performed as the last assembly step. The gasket is supplied with pressure sensitive adhesive. Once the gasket is installed it can't be removed without damaging the gasket. Remove the paper release liner exposing the adhesive. Place the gasket with the adhesive side of the gasket onto the control node. The gasket shall be centered within the skirt of the cover, then press the gasket against the surface of the base ensuring the gasket is adhered to the base. Inspect the gasket for any damage.

4.8 Workmanship

The LENEBA must not be damaged in any way. Inspect base assembly for proper contacts and ensure contacts are not damaged or bent. If assembling cover to base, ensure three cover latches are fully latched to base. Inspect interfacial foam seal for proper positioning on base and ensure foam seal is not torn or damaged.

4.9 Mating and Un-Mating Control Node to Receptacle

Align control node blades with receptacle power contact circuits. Note that the neutral blade is larger than the line and load blades, providing mating polarization. After properly aligning the blades to the receptacle power contact circuits, push downward until the photocell is bottomed on the receptacle's mating surface, slightly compressing gasket of the photocell. Twist the control node in a clockwise direction. The contacts will lock into position, fully mating the control node to the receptacle. To un-mate, twist the control node in a counter-clockwise direction and pull the control node away from the receptacle until the power blades are disengaged from the receptacle.

4.10 Replacement and Repair

The contacts and housings and LPCBA are not repairable. DO NOT use an assembly with damaged or defective contacts and/or housings. If damaged, replace the receptacle assembly with a new one. Note that once the cover is installed onto the control node, it can't be removed.

4.11 Tooling

An assembly fixture and a small press may be required to assemble the cover to the base.