



Chipsmall Limited consists of a professional team with an average of over 10 year of expertise in the distribution of electronic components. Based in Hongkong, we have already established firm and mutual-benefit business relationships with customers from,Europe,America and south Asia,supplying obsolete and hard-to-find components to meet their specific needs.

With the principle of "Quality Parts,Customers Priority,Honest Operation,and Considerate Service",our business mainly focus on the distribution of electronic components. Line cards we deal with include Microchip,ALPS,ROHM,Xilinx,Pulse,ON,Everlight and Freescale. Main products comprise IC,Modules,Potentiometer,IC Socket,Relay,Connector.Our parts cover such applications as commercial,industrial, and automotives areas.

We are looking forward to setting up business relationship with you and hope to provide you with the best service and solution. Let us make a better world for our industry!



Contact us

Tel: +86-755-8981 8866 Fax: +86-755-8427 6832

Email & Skype: info@chipsmall.com Web: www.chipsmall.com

Address: A1208, Overseas Decoration Building, #122 Zhenhua RD., Futian, Shenzhen, China



3M™ TEXTTOOL™ OPEN-TOP SOCKETS FOR QFN APPLICATIONS

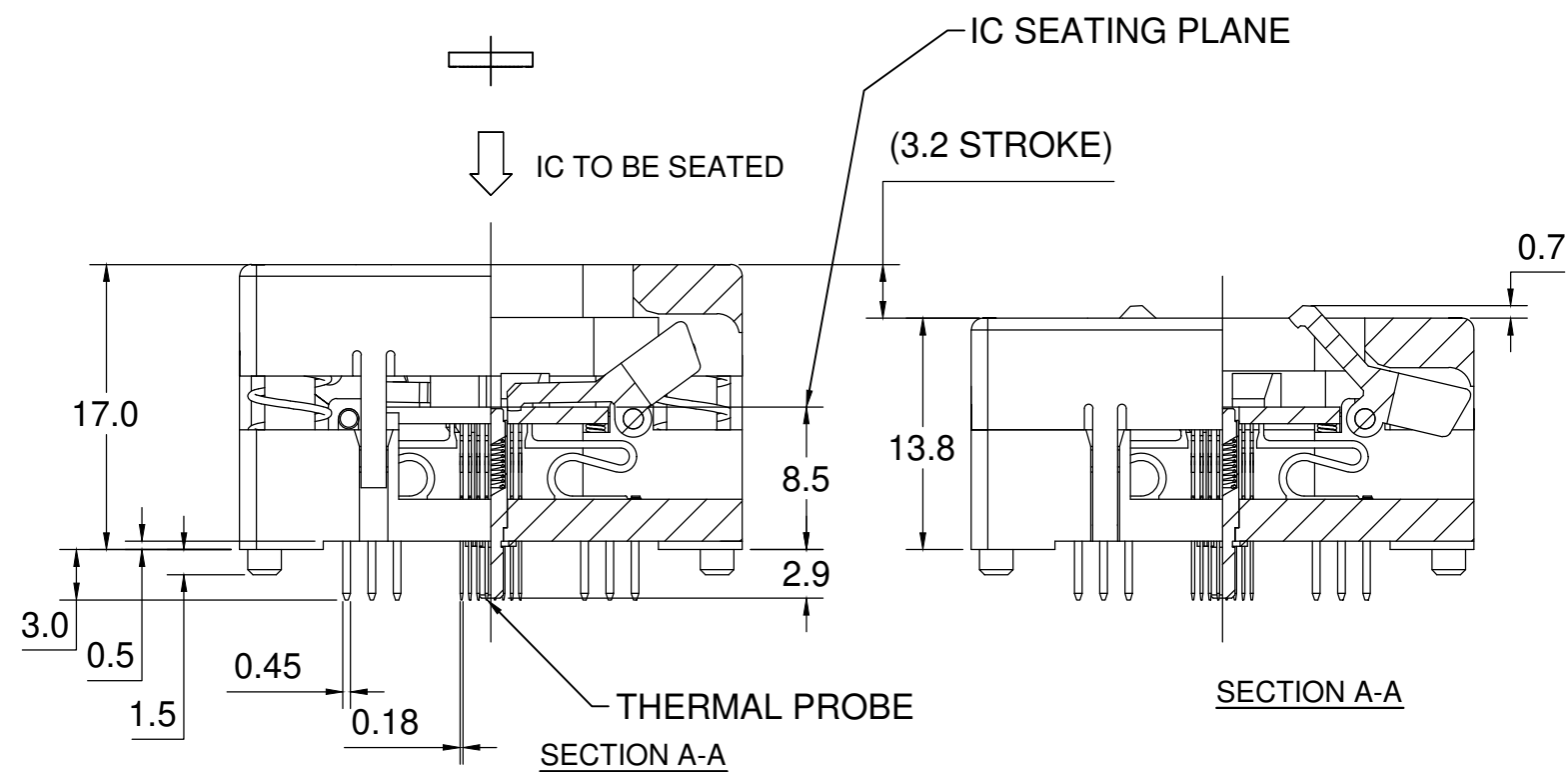
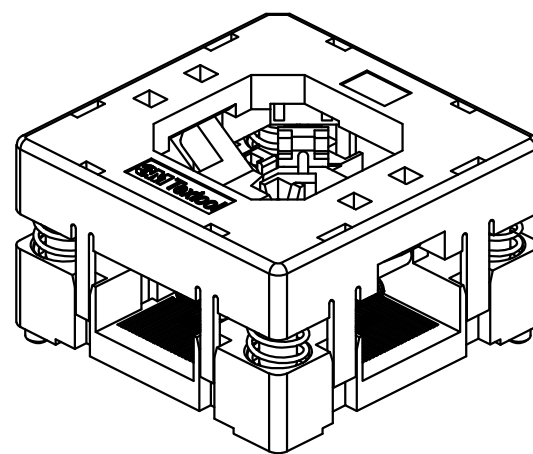
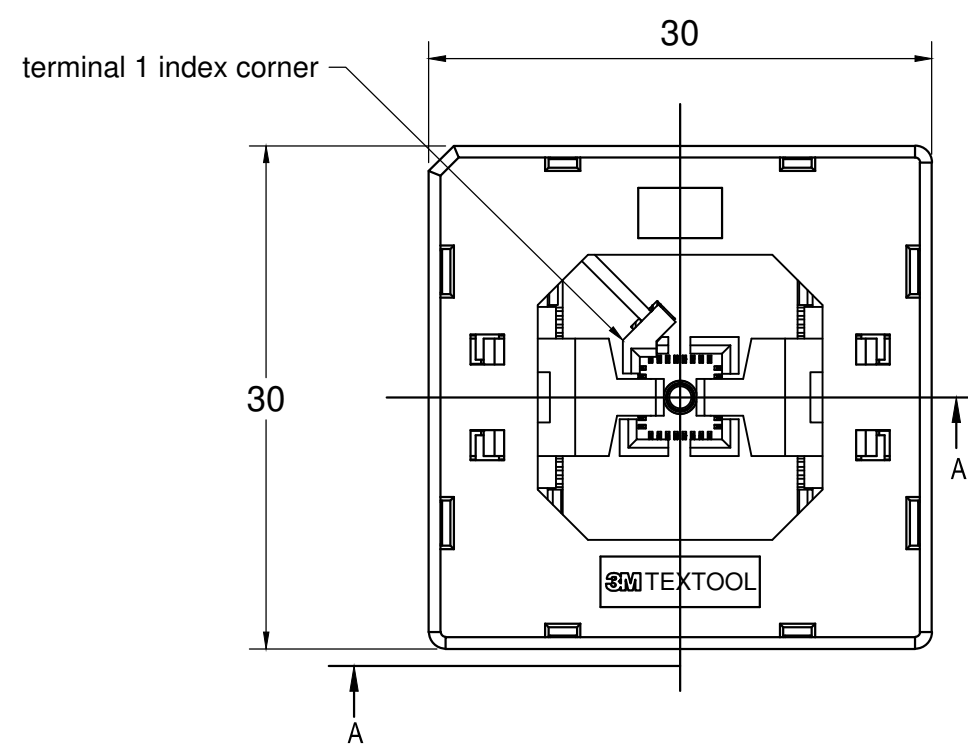

NOTES:

1. MATERIALS:

SPRINGS	SS	PLATING : Au
CONTACTS	Be Cu	COLOR : BLACK
IC GUIDES	PES	COLOR : BLACK
PRESSURE PAD	PES	COLOR : BLACK
COVER	PPS or equiv.	COLOR : BLACK
BASE	PES	COLOR : BLACK

2. SEE THE REGULATORY INFORMATION APPENDIX (RIA) IN THE "RoHS COMPLIANCE" SECTION WWW.3MCONNECTOR.COM FOR COMPLIANCE INFORMATION (RIA E1 & C1 APPLY).

3. FOR PRODUCT SPECIFICATIONS AND WARRANTY INFORMATION SEE:

WWW.3MCONNECTOR.COM PN 232-5205-01

DESIGN REFERENCE		NEXT ASSEMBLY		A	37213	INITIAL RELEASE	ARM		
DISTRIBUTION CODES		TOLERANCES EXCEPT AS NOTED		REV	ECO	ISSUE DATE AND DESCRIPTION	DRFT	CHKD	
DIVISION		INCHES		DRFT		DATE	MFG	DATE	
DO NOT SCALE DRAWING		MILLIMETERS		CHKD		DATE	APPVL	DATE	
SCALE 5/1		THIRD ANGLE PROJECTION						© 3M COPYRIGHT 2012 This document is the copyrighted property of the 3M Company and may not be reproduced without 3M written permission or used for other than 3M authorized purposes.	
INTERPRET PER ASME Y14.5 - 1994		MAX SURFACE ROUGHNESS		QFN TEST SOCKET, 0.5mm, 32 pos, EVEN ROW, 5X5 PKG, WITH TP				CAGE NUMBER C DRAWING NO. 78-5100-2468-6 REV. A	
125 <input type="checkbox"/> ALL SURFACES <input checked="" type="checkbox"/> MARKED ONLY		ANGLES ± 1°		MODEL TEXTTOOL - QFN		DET. LISTS <input type="checkbox"/> YES <input checked="" type="checkbox"/> NO		SHT 1 OF 2	

3M™ TEXTTOOL™ OPEN-TOP SOCKETS FOR QFN APPLICATIONS

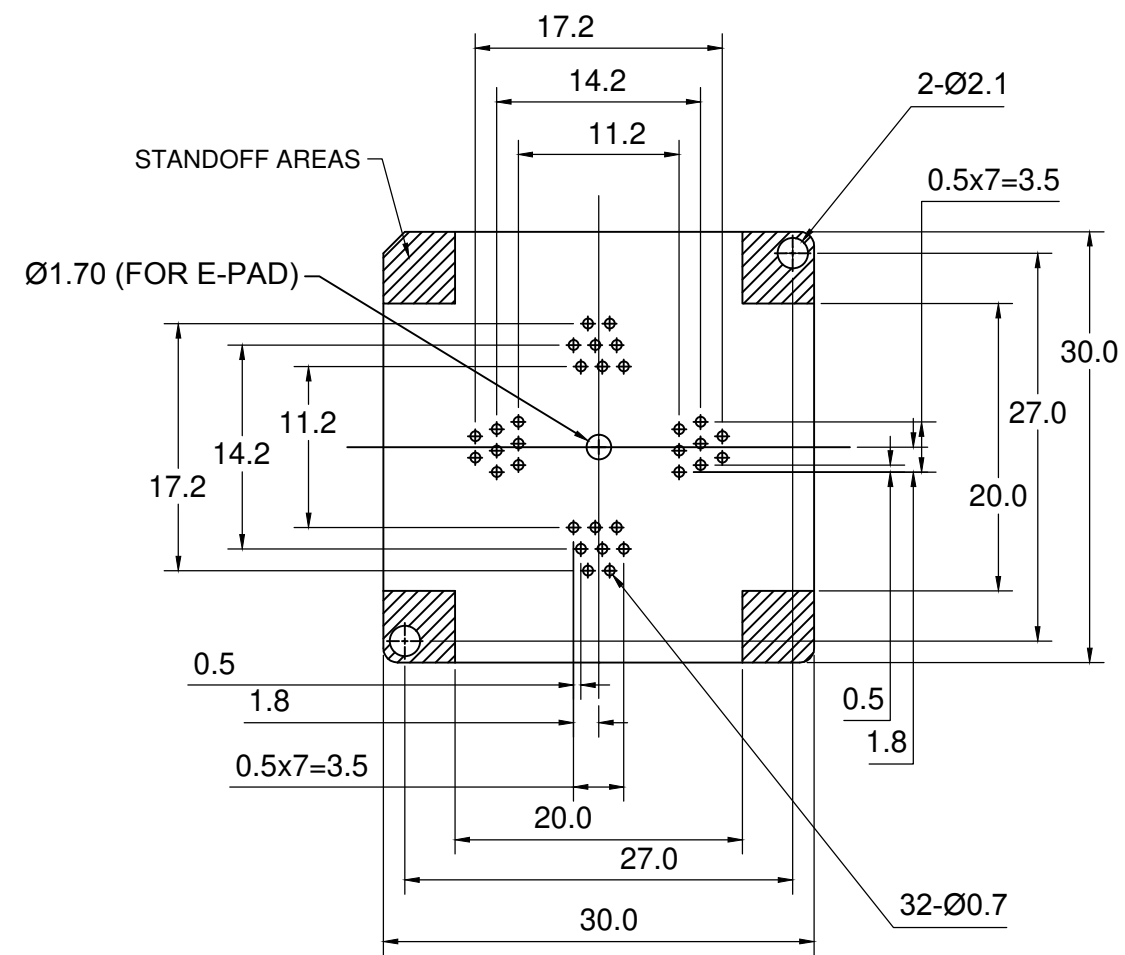

FOOTPRINT AS VIEWED LOOKING DOWN FROM TOP OF SOCKET

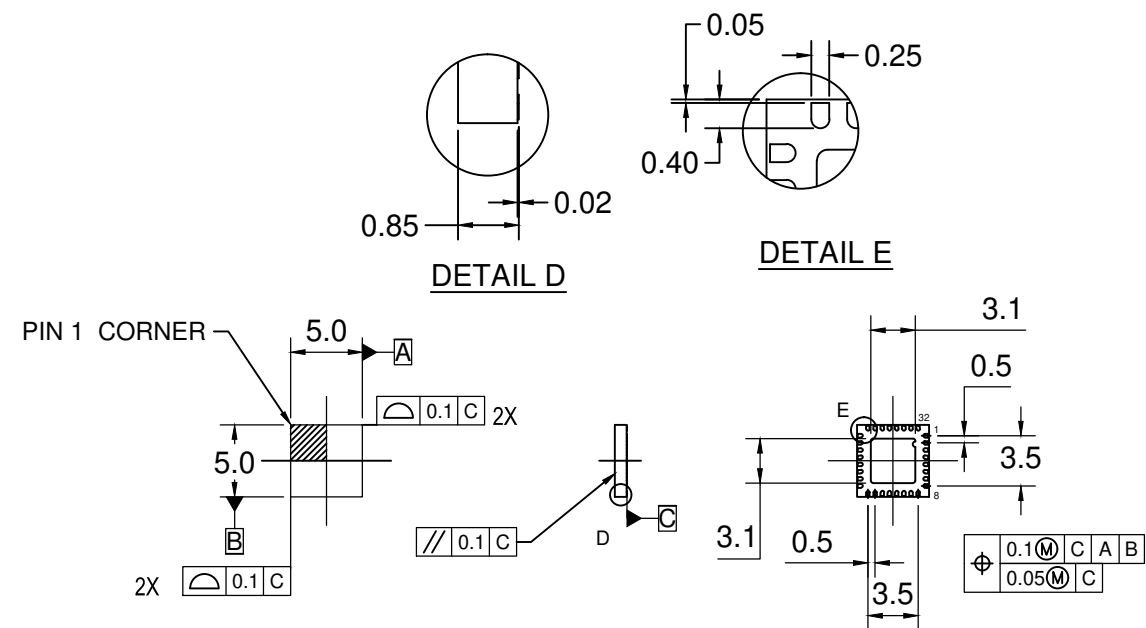

RECOMMENDED IC (REF.)

DESIGN REFERENCE	NEXT ASSEMBLY	REV	ECO	ISSUE DATE AND DESCRIPTION	DRFT	CHKD
DISTRIBUTION CODES		DRFT		DATE	MFG	DATE
		CHKD		DATE	APPVL	DATE
DIVISION	DIVISION CODE	3M		3M Center St. Paul, MN 55144	© 3M COPYRIGHT 2012 This document is the copyrighted property of the 3M Company and may not be reproduced without 3M written permission or used for other than 3M authorized purposes.	
DO NOT SCALE DRAWING	SCALE 5 1	TOLERANCES EXCEPT AS NOTED		TITLE QFN TEST SOCKET, 0.5mm, 32 pos, EVEN ROW, 5X5 PKG, WITH TP		
THIRD ANGLE PROJECTION	INTERPRET PER ASME Y14.5 - 1994	INCHES .0 ± .1 .00 ± .02 .000 ± .005 .0000 ± .0002		MILLIMETERS 0 ± .1 .0 ± .02 .00 ± .005 .000 ± .0002		
MAX SURFACE ROUGHNESS 125 ✓ <input type="checkbox"/> ALL SURFACES ✓ <input checked="" type="checkbox"/> MARKED ONLY		CAGE NUMBER C		DRAWING NO. 78-5100-2468-6	REV. A	
		MODEL TEXTTOOL - QFN		DET. LISTS <input type="checkbox"/> YES <input checked="" type="checkbox"/> NO	SHT 2 OF 2	