



Chipsmall Limited consists of a professional team with an average of over 10 year of expertise in the distribution of electronic components. Based in Hongkong, we have already established firm and mutual-benefit business relationships with customers from,Europe,America and south Asia,supplying obsolete and hard-to-find components to meet their specific needs.

With the principle of “Quality Parts,Customers Priority,Honest Operation,and Considerate Service”,our business mainly focus on the distribution of electronic components. Line cards we deal with include Microchip,ALPS,ROHM,Xilinx,Pulse,ON,Everlight and Freescale. Main products comprise IC,Modules,Potentiometer,IC Socket,Relay,Connector.Our parts cover such applications as commercial,industrial, and automotives areas.

We are looking forward to setting up business relationship with you and hope to provide you with the best service and solution. Let us make a better world for our industry!



## Contact us

Tel: +86-755-8981 8866 Fax: +86-755-8427 6832

Email & Skype: info@chipsmall.com Web: www.chipsmall.com

Address: A1208, Overseas Decoration Building, #122 Zhenhua RD., Futian, Shenzhen, China





# 2330QD, 2332QD and 2390QD Series Non-Relampable Neon-Incandescent Indicator Light

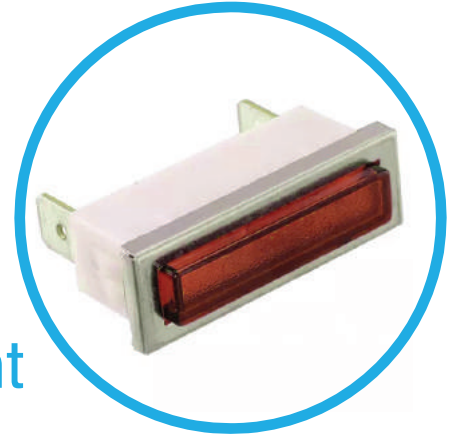

Rectangular Neon-Incandescent Quick Connect Terminals Indicator Lights for 0.400" x 1.280" mounting hole

## Specifications

Mounting: Will snap-fit into cut-out 0.400" x 1.280" and will mount in .032" - .100" thick panels

Terminals: Quick-connect, tinned brass, 0.250"

Lens: Polycarbonate

Bezel: Stainless steel.

Underwriters Laboratories (UL) File No. E20356

## Ordering Information

	Neon	Incandescent
	(105 - 125 VAC)	(28 VAC/VDC)
Lens Color	Part No.	Part No.
Red	2330QD1	2390QD1-28V
Amber	2330QD3	2390QD3-28V
White	2330QD4	2390QD4-28V
Green	2332QD5*	2390QD5-28V
Lamp used	C6A+Resistor	Lamp #: 2187

\*Incorporates G2B lamp and resistor

## Dimensions

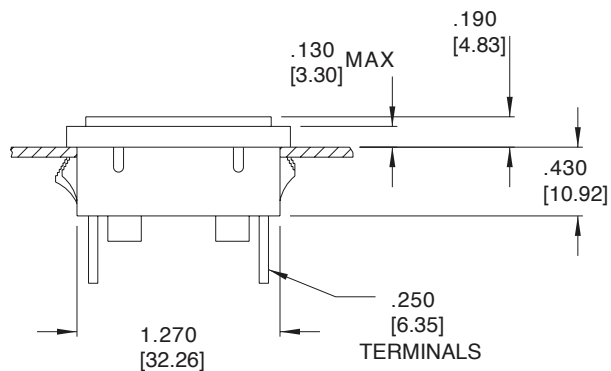

### MOUNTING HOLE

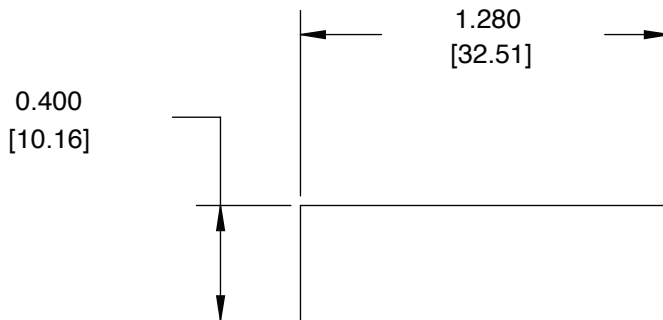

All dimensions in inches [mm].

## Compliances and Approvals

