



Chipsmall Limited consists of a professional team with an average of over 10 year of expertise in the distribution of electronic components. Based in Hongkong, we have already established firm and mutual-benefit business relationships with customers from,Europe,America and south Asia,supplying obsolete and hard-to-find components to meet their specific needs.

With the principle of "Quality Parts,Customers Priority,Honest Operation,and Considerate Service",our business mainly focus on the distribution of electronic components. Line cards we deal with include Microchip,ALPS,ROHM,Xilinx,Pulse,ON,Everlight and Freescale. Main products comprise IC,Modules,Potentiometer,IC Socket,Relay,Connector.Our parts cover such applications as commercial,industrial, and automotives areas.

We are looking forward to setting up business relationship with you and hope to provide you with the best service and solution. Let us make a better world for our industry!



## Contact us

Tel: +86-755-8981 8866 Fax: +86-755-8427 6832

Email & Skype: info@chipsmall.com Web: www.chipsmall.com

Address: A1208, Overseas Decoration Building, #122 Zhenhua RD., Futian, Shenzhen, China



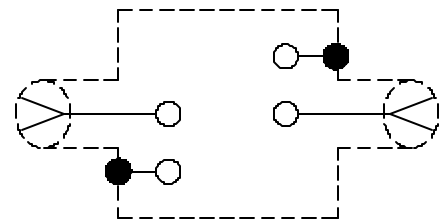
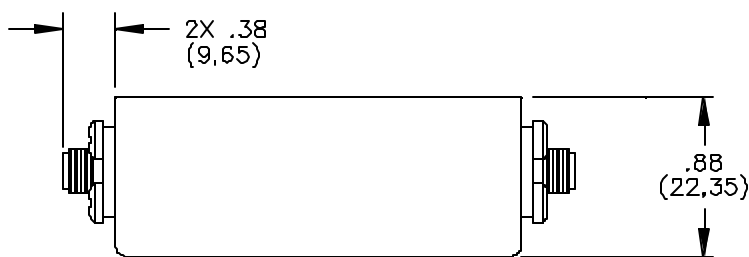
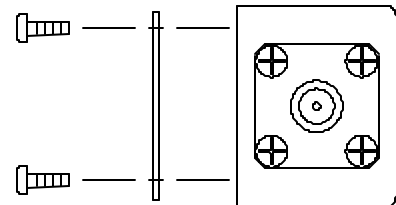
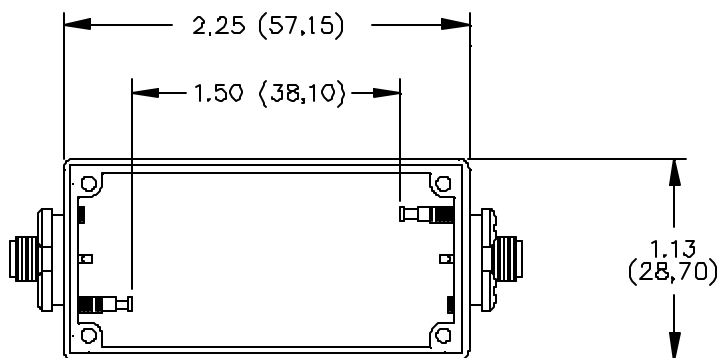

SCHEMATIC

## MATERIALS:

Connector: 2 ea. SMA Receptacle. Body: Tarnish Resistant Plating, Center Contact: Gold Plated Beryllium Copper  
 Solder Turret Terminal Screws: Steel  
 Shielded Housing: Die cast aluminum alloy A380 or A384.  
 Finish: Blue paint per Federal Standard 595 #25109 over Phosphoric Etch  
 Cover: .040 Thick aluminum alloy #1100-H14  
 Finish: Clear Anodized  
 Screws: Steel 4 ea. #2-32 x 1/4" Pan Head, self-tapping

## RATINGS:

Operating Voltage: Inner conductor/Shield: 335 VRMS Max.  
 Operating Temperature: -55°C to +150°C  
 Nominal Impedance: 50 Ohms

## ORDERING INFORMATION: Model 2399

All dimensions are in inches. Tolerances (except noted): .xx = ±.02" (.51 mm), .xxx = ±.005" (.127 mm).  
 All specifications are to the latest revisions. Specifications are subject to change without notice.  
 Registered trademarks are the property of their respective companies. Made in USA