



Chipsmall Limited consists of a professional team with an average of over 10 year of expertise in the distribution of electronic components. Based in Hongkong, we have already established firm and mutual-benefit business relationships with customers from,Europe,America and south Asia,supplying obsolete and hard-to-find components to meet their specific needs.

With the principle of “Quality Parts,Customers Priority,Honest Operation,and Considerate Service”,our business mainly focus on the distribution of electronic components. Line cards we deal with include Microchip,ALPS,ROHM,Xilinx,Pulse,ON,Everlight and Freescale. Main products comprise IC,Modules,Potentiometer,IC Socket,Relay,Connector.Our parts cover such applications as commercial,industrial, and automotives areas.

We are looking forward to setting up business relationship with you and hope to provide you with the best service and solution. Let us make a better world for our industry!



Contact us

Tel: +86-755-8981 8866 Fax: +86-755-8427 6832

Email & Skype: info@chipsmall.com Web: www.chipsmall.com

Address: A1208, Overseas Decoration Building, #122 Zhenhua RD., Futian, Shenzhen, China



SPEAKER-1318-2.5-SC-GRAND

The 13x18x2.5 mm Grand speaker provides maximum space efficiency and audio performance in small, slim consumer devices, such as mobile handsets or smartphones. The extremely flat speaker has the same space consumption compared to conventional 11x15x3.5 mm speakers but provides an improved acoustic performance resulting in a lower resonance frequency (750Hz) and higher power handling capacity (600mW).

An advanced triple magnet concept provides optimized acoustic sensitivity.

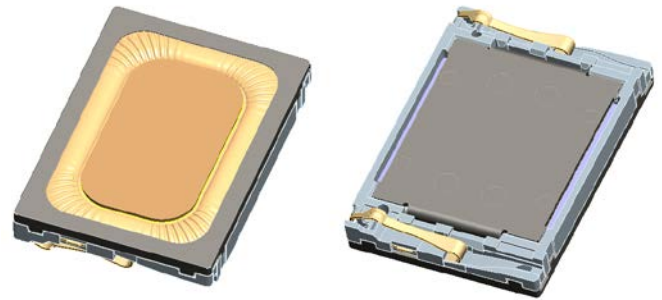

Features:

- Extremely slim design with only 2.5mm height
- Low resonance frequency (750Hz)
- 600 mW power handling capacity
- Triple magnet technology for improved sensitivity
- Very robust spring connectors
- 100% in-line measurement of all specified electrical and acoustical parameters

Contents

1.	Mechanical Layout and Dimensions.....	3
1.1.	Main Dimensions.....	3
1.2.	PWB Layout Top View	4
1.3.	Spring Force.....	5
1.4.	Force on component	6
1.5.	Part marking/labeling.....	7
1.6.	Material list.....	8
2.	Electro-acoustic characteristics.....	9
2.1.	Frequency response	9
2.2.	Electro-Acoustic Parameters	10
2.3.	Power handling.....	10
2.4.	Measurement setup	11
2.5.	Measured Parameters.....	11
2.6.	Measurement Adapter	12
3.	Environmental Conditions.....	13
3.1.	Storage.....	13
3.2.	Transportation.....	13
3.3.	Functionality.....	13
4.	Environmental tests	14
4.1.	Qualification tests.....	14
4.2.	Reliability tests	14
4.3.	Sample Size, Sequence	14
4.4.	Period of Shelf-Life	14
4.5.	Testing Procedures.....	14
5.	Related Documents	17
6.	Additional documents	17
7.	Change History	18
8.	Disclaimer	18

2403 260 00071

1. Mechanical Layout and Dimensions

1.1. Main Dimensions

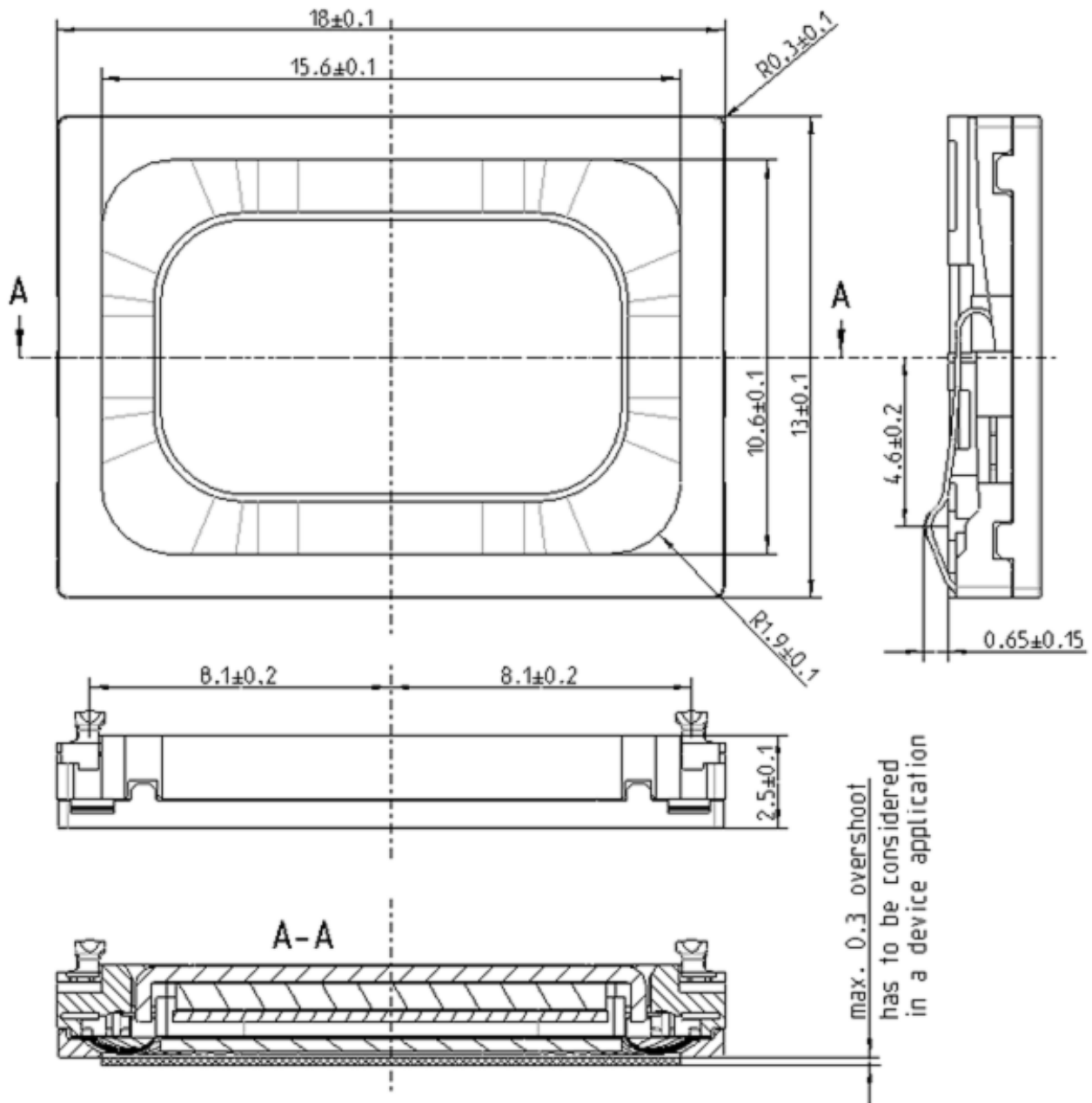

2403 260 00071

1.2. PWB Layout Top View

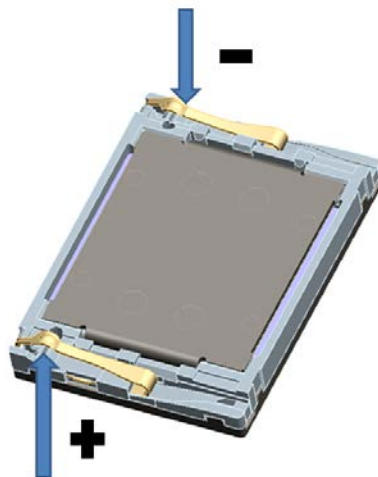
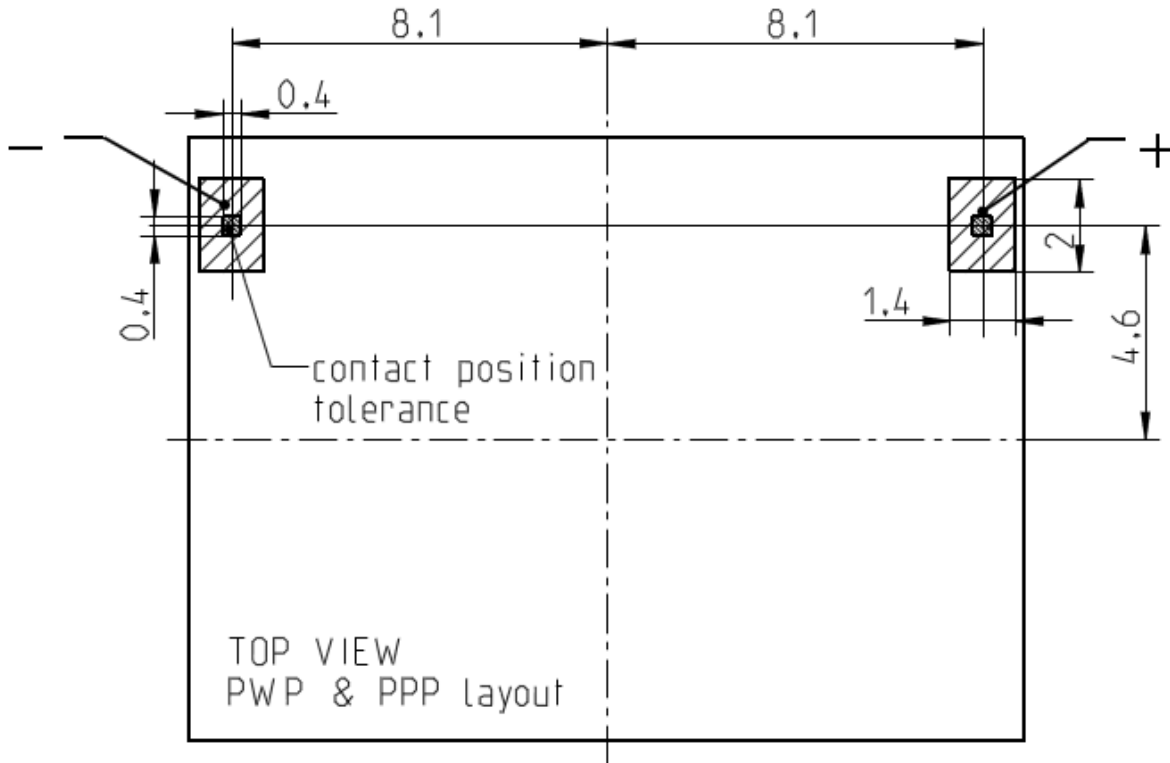

positive voltage on pin +
moves membrane in direction of arrow

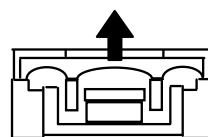

2403 260 00071

1.3. Spring Force

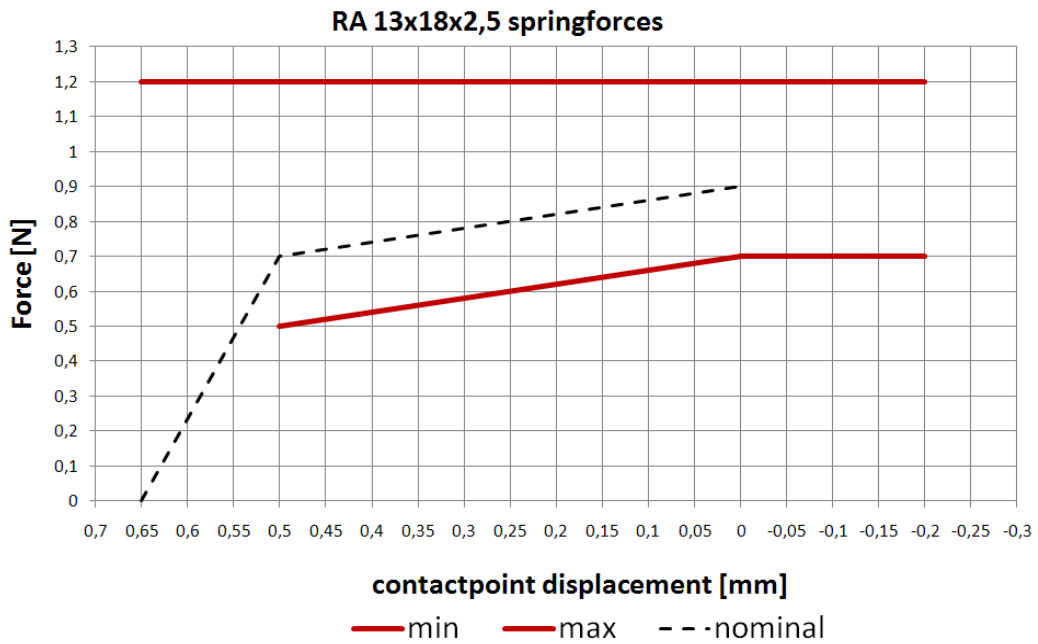
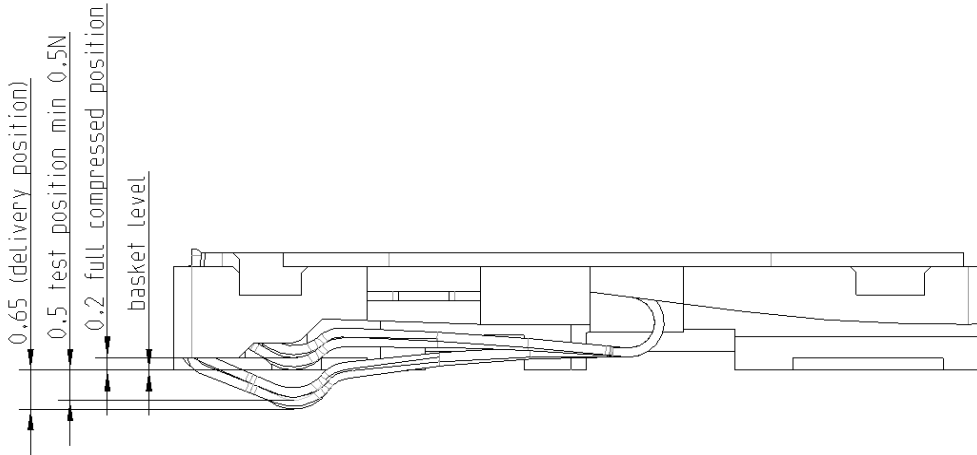

SPRING FORCE TABLE		
Force at Baskte level	0 mm	max 1,2 N
Force at Start Workingposition	0,5 mm	min 0,5N
uncompressed (delivery position)	0,65 +/- 0,15mm	0 N
Force at PPP level	-0,2 mm	max 1,2 N

2403 260 00071

1.4. Force on component

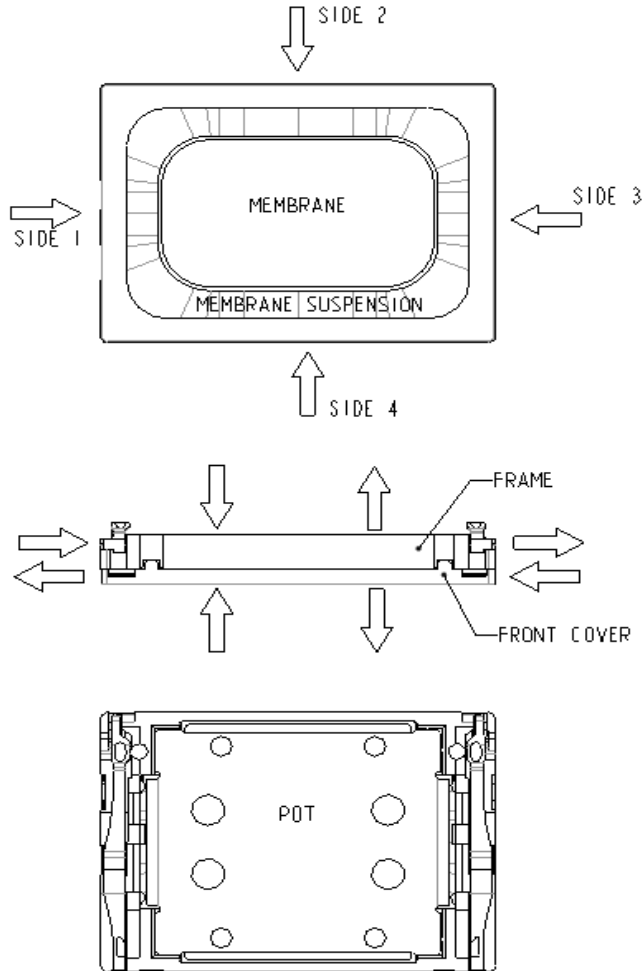

FORCES ON DIFFERENT STATE OF COMPONENT			
STATE	MIN. SURFACE OF PRESSURE [mm ²]	MAX PERMANENT FORCE [N]	MAX HANDLING FORCE [N]
SIDE FORCE ON FRONT COVER AND FRAME (1,2,3,4)	10	10	15
PUSH FORCE FRONT COVER	Complete top area	10	15
PULL FORCE FRONT COVER	Complete top area	5	10
PUSH FORCE POT	10	10	20
PULL FORC POT	10	5	10
PUSH FORCE MEMBRANE AND SUSPENSION	0	0	0
PULL FORCE MEMBRANE AND SUSPENSION	0	0	0
PUSH FORCE FRAME BACKSIDE	10	10	20
SHEER FORCE FRONT COVER-FRAME	10	15	20

2403 260 00071

1.5. Part marking/labeling

The products have a serial number on bottom (pot) side

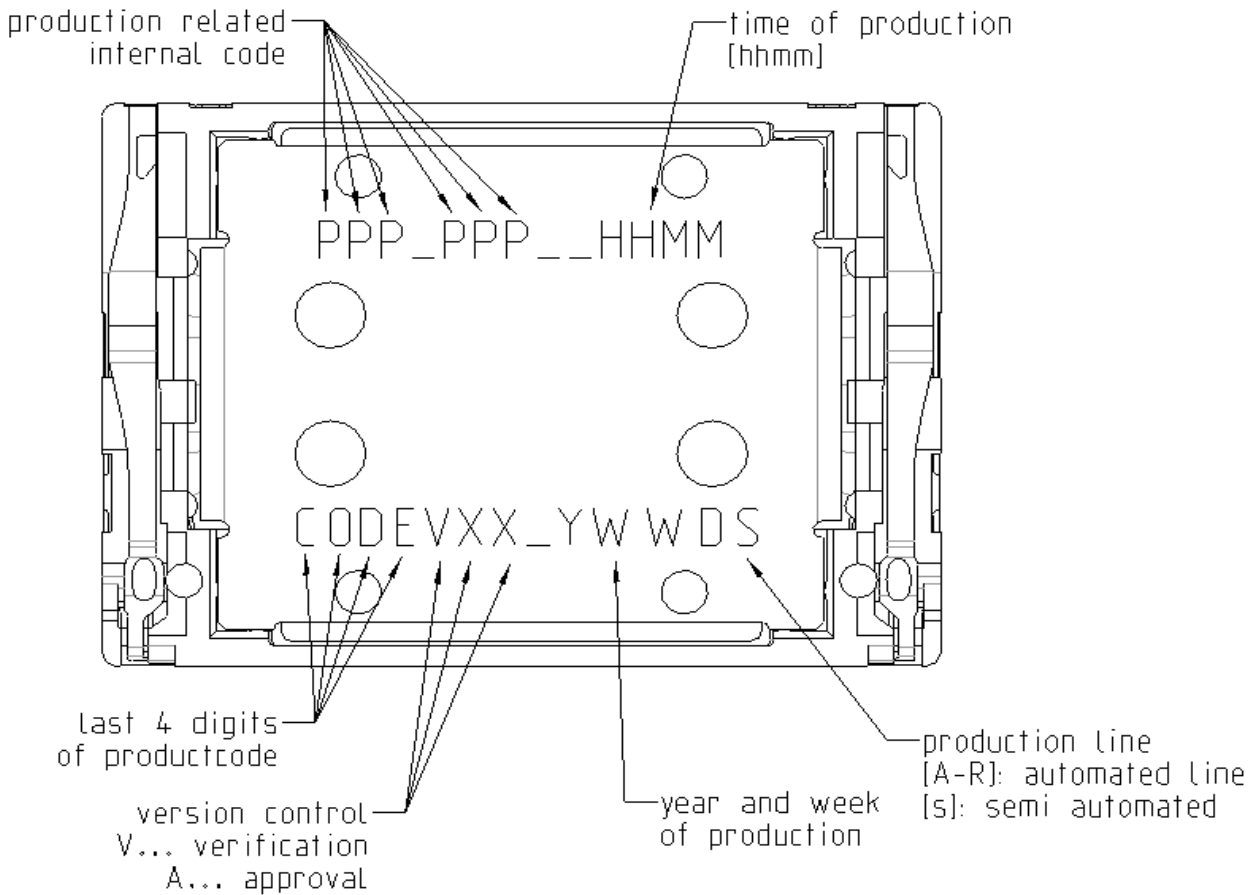

2403 260 00071

1.6. Material list

- | | |
|--------------------------|------------------------------|
| 1. MATERIAL of BASKET: | Polycarbonate (Halogen free) |
| 2. MATERIAL of MEMBRANE: | Polyarylate-Compound |
| 3. MATERIAL of POT: | soft magnetic iron |
| 4. MATERIAL of MAGNET: | Nd Fe B |
| 5. MATERIAL of CONTACT | CrNi Steel gold plated |
| 6. MATERIAL of COVER: | Polybutylene |
| 7. DIMENSION: | 13x18x2,5 |
| 8. MASS: | 1,65 g |

2403 260 00071

2. Electro-acoustic characteristics

2.1. Frequency response

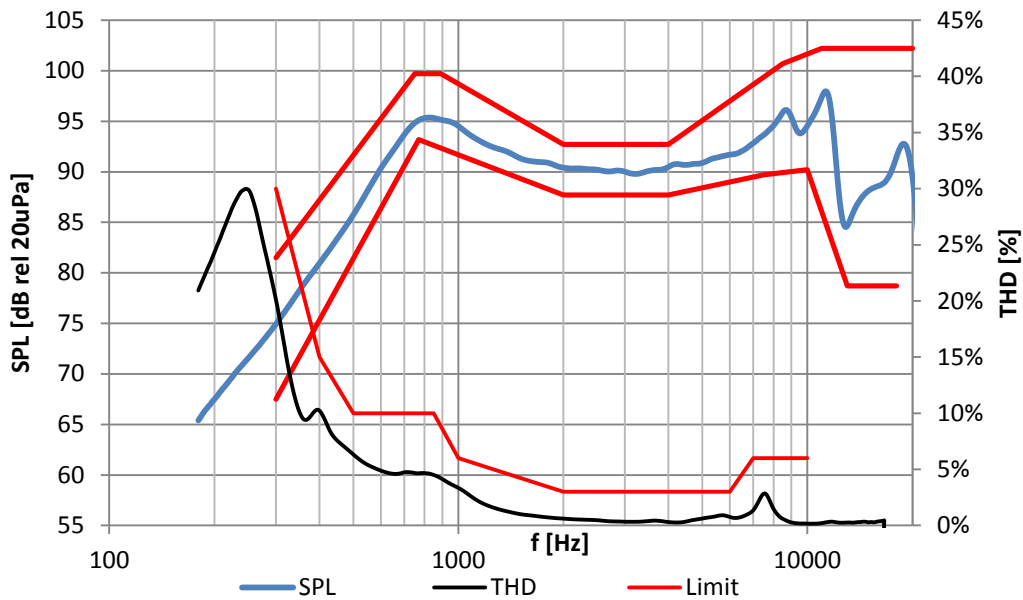

TYPICAL FREQUENCY RESPONSE measured on Baffle according to Chapter 2.4 : distance d = 10cm, P= 600mW, 1ccm back cavity

f	lower limit (floating)	f	upper limit(Floating)	f	upper limit
[Hz]	[dB SPL]	[Hz]	[dB SPL]	[Hz]	[%THD]
300	67.5	300	81.5	300	30%
770	93.2	750	99.7	400	15%
2000	87.7	890	99.7	500	10%
4000	87.7	2000	92.7	850	10%
7500	90	4000	92.7	1000	6%
10000	90.2	8500	100.7	2000	3%
13000	78.7	11000	102.2	6000	3%
18000	78.7	20000	102.2	7000	6%
				10000	6%

2403 260 00071

2.2. Electro-Acoustic Parameters

LOUDSPEAKER MOUNTED IN ADAPTER ACC. TO 2.6

1. RATED IMPEDANCE	Z:	8 Ω
2. VOICE COIL RESISTANCE	R:	7.2 $\Omega \pm 10 \%$
3. RESONANCE FREQUENCY At 600mW, 1ccm	f_0 :	750 Hz $\pm 7.5 \%$
4. MAXIMUM useable EXCURSION	Xmax:	+/- 0.30mm
5. NOMINAL CHARACT. SENSITIVITY (calculated for 1W in 1m) average from 2kHz to 4kHz		73 ± 2.5 dB
5.1. MEASURED CHARACT. SENSITIVITY (at 600mW in 1cm) average from 2kHz to 4kHz		110.8 ± 2.5 dB
6. THD		according to chapter 2.1
7. RUB & BUZZ		no audible rub & buzz

2.3. Power handling

SPEAKER MOUNTED IN LIFETIME TEST DEVICE (closed Box 1ccm, open front)
(pink noise, 2nd order high pass, f-3dB at 800Hz, Crest factor of 2 (6 dB))

1.	MAX.SHORT TERM POWER (0,5sec. ON / 3sec. OFF)	1000mW (RMS)
2.	MAX. CONTINUOUS POWER (500h)	600mW (RMS)

2.4. Measurement setup

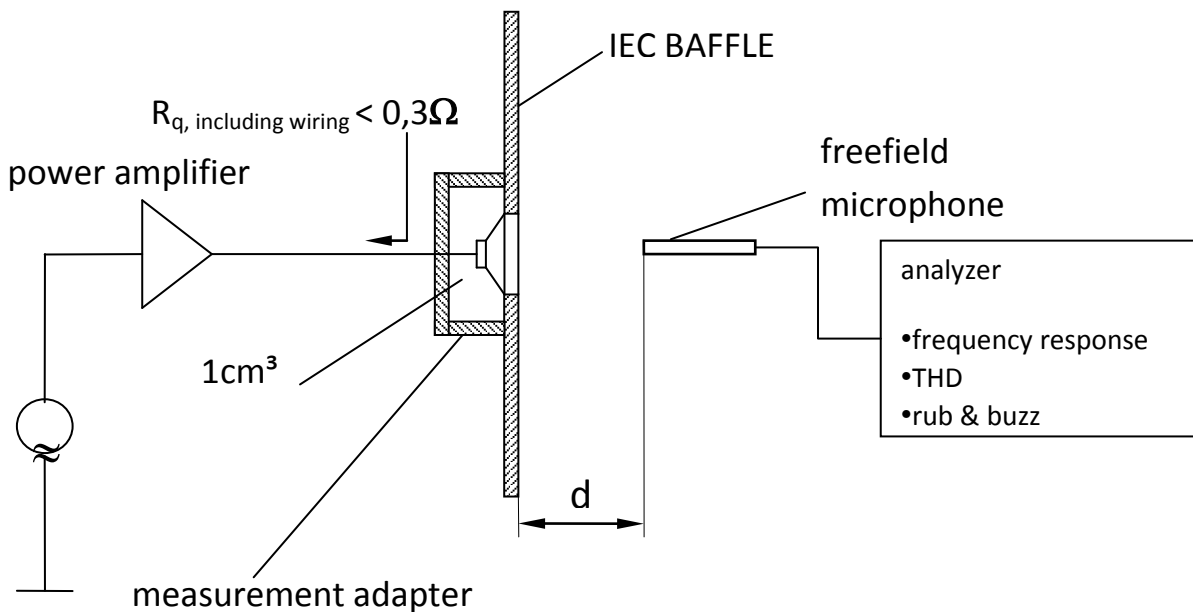

2.5. Measured Parameters

2.5.1. Sensitivity

SPL is expressed in dB rel $20\mu\text{Pa}$, computed according to IEC 268-5. Measurement set up and parameters according chapter 2.4. This test is performed for 100% of products in the production line.

2.5.2. Frequency response

Frequency response is measured according test set up in chapter 2.4 data sheet and checked against the tolerance window defined in chapter 2.1. This Test is performed for 100% of products in the production line.

2.5.3. Total harmonic distortion (THD)

Is measured according IEC 268-5 (2nd to 5th harmonics) and test set up in chapter 2.4. This test is performed for 100% of products in the production line.

2.5.4. Rub& Buzz

Rub & Buzz will be measured in the Inline-measuring device with a sinusoidal sweep. Rub and Buzz is defined as the maximum peak sound pressure in transmission range of the 5kHz high pass filter. Signal and evaluation criteria are according to chapter 2.2. This test is performed for 100% of products in the production line.

2403 260 00071

2.6. Measurement Adapter

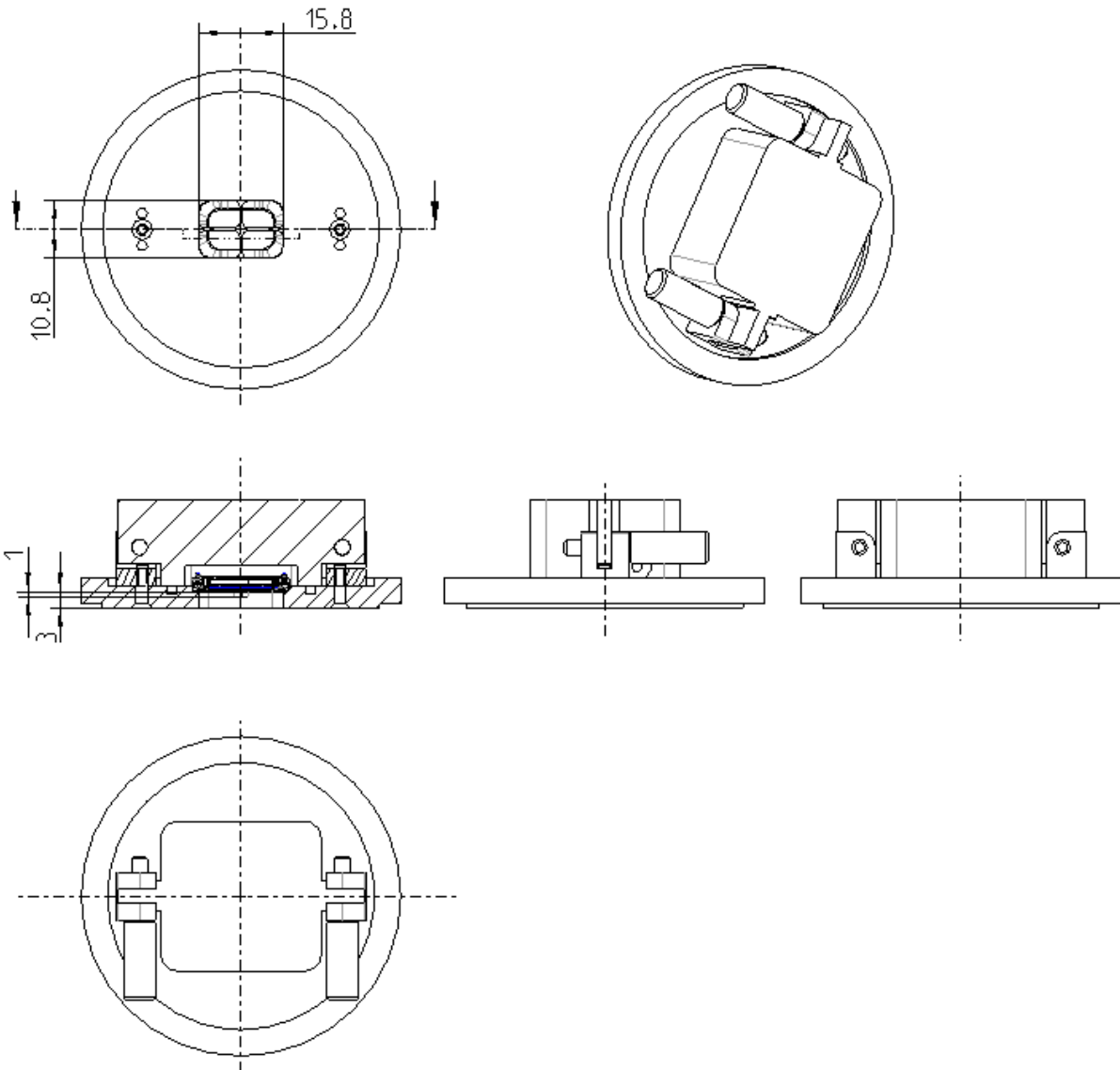

2403 260 00071

3. Environmental Conditions

3.1. Storage

The transducer fulfills the specified data after treatment according to the conditions of

ETS 300 019-2-1 Specification of environmental test: Storage
Test spec. T 1.2: Weather protected, not temperature controlled storage locations.

3.2. Transportation

The transducer fulfills the specified data after treatment according to the conditions of

ETS 300 019-2-2 Specification of environmental test: Transportation
Test Spec. T 2.3: Public Transportation

3.3. Functionality

The transducer fulfills the specified data after treatment according to the conditions of

ETS 300 019-2-5 Specification of environmental test: Ground vehicle installations
Test spec. T 5.1: Protected installation

ETS 300 019-2-7 Specification of environmental test: Portable and non-stationary use
Test spec. T 7.3E: Partly weather protected and non-weather protected locations.

4. Environmental tests

4.1. Qualification tests

According to our milestone plan (Product Creation Process), a complete qualification test will be done at design validation of products manufactured under serial conditions.

1x per year and product family a requalification takes place. The qualification process covers all tests described under 4.5 and a complete inspection.

4.2. Reliability tests

1x per month and product family samples are taken and submitted to tests described under 4.5.2

4.3. Sample Size, Sequence

Unless otherwise stated 20 arbitrary new samples will be used to perform each test for both, qualification and requalification test as described under 4.1 and 4.2.

4.4. Period of Shelf-Life

The period of shelf-life is 2 years.

4.5. Testing Procedures

4.5.1. Storage Tests

4.5.1.1. Low Temperature Storage Test

Parameter	Test Method and Conditions	Duration	Evaluation Standard
Low Temperature Storage (Ref. EN 60068-2-1)	-40°C rel. humidity not controlled	168h	Measurements after 2 hours recovery time. All samples fully operable. All acoustical parameters according specification with tolerances increased by 50 %.

4.5.1.2. High Temperature Storage Test

Parameter	Test Method and Conditions	Duration	Evaluation Standard
Dry Heat Storage (Ref. EN 60068-2-2)	+85°C rel. humidity not controlled	168h	Measurements after 2 hours recovery time. All samples fully operable. All acoustical parameters according specification with tolerances increased by 50 %.

4.5.1.3. Temperature Cycle Test

Parameter	Test Method and Conditions	Duration	Evaluation Standard
Change of Temperature (Ref. EN 60068-2-14)	-40°C/+85°C Transition time <3 min.	20 cycles 30 min for each temperature	Measurements after 2 hours recovery time. All samples fully operable. All acoustical parameters according specification with tolerances increased by 50 %.

4.5.1.4. Temperature / Humidity Cycle Test

Parameter	Test Method and Conditions	Duration	Evaluation Standard
Damp heat, cyclic (Ref. IEC 60068-2-30)	+30°C/+65°C 90% to 95% RH. Temp. change time 1,5h <u>Caution:</u> no condensed water on products!	18 cycles. 1h each +30°C 4h at +65°C Temp. change time 1,5h Totally 144h	Measurements after 2 hours recovery time. All samples fully operable. All acoustical parameters according specification with tolerances increased by 50 %.

4.5.2. Operating Tests

4.5.2.1. Cold Operation Test

Parameter	Test Method and Conditions	Duration	Evaluation Standard
Cold Operation Test (Ref. EN 60068-2-1)	-20°C rel. humidity not controlled signal acc. Chapter 2.3	72h	Measurements after 2 hours recovery time. All samples fully operable. THD may be increased after test. All other acoustical parameters according specification with tolerances increased by 50 %.

4.5.2.2. Dry Heat Operation Test

Parameter	Test Method and Conditions	Duration	Evaluation Standard
Dry Heat Operation (Ref. EN 60068-2-2)	+70°C rel. humidity not controlled signal acc. Chapter 2.3	500h	Measurements after 2 hours recovery time. All samples fully operable. The allowable change in sensitivity shall not be greater than 3 dB. All other acoustical parameters according specification with tolerances increased by 50 %.

2403 260 00071

4.5.3. Salt Mist Test

Parameter	Test Method and Conditions	Duration	Evaluation Standard
Salt Mist (Ref. IEC60068-2-52, Kb / Severity 2)	The part must be subjected to 2 hours spray of 5% NaCl salt mist, at 35°C then be left at 40°C and 95% RH for 22h.	3 cycles; Total test time 72h	The samples shall be washed after the test with distilled water and dried at T< 50°C. Component may have reduced performance, but must still function properly. The allowable sensitivity difference shall not be greater than ±3dB from initial sensitivity.

4.5.4. Shock Resistance Test (Free Fall Test) - protected product

Parameter	Test Method and Conditions	Conditions / Sample size	Evaluation Standard
Mechanical shock (Ref. IEC60068-2-32 Ed)	Drop in test box or test adapter of release plane from a height of 1.5m onto concrete floor.	Two drops on each side (2x6); One drop on each edge (1x12); Two drops on each corner (2x8); 40 drops in total.	Component may have reduced performance, but must still function properly. The allowable sensitivity difference shall not be greater than ±3dB from initial sensitivity.

4.5.5. Impact Durability Test (Tumble Test) – protected product

Parameter	Test Method and Conditions	Conditions / Sample size	Evaluation Standard
Impact durability (in a Tumble Tester) (Ref. IEC60068-2-32 Ed) (SPR a7.1.1)	Speaker in drop test box or representative mechanics. Random drops on steel base.	20 units 100 drops, 1m DUT power off	Component may have reduced performance, but must still function properly. The allowable sensitivity difference shall not be greater than ±3 dB from initial sensitivity.

4.5.6. Resistance to Electrostatic Discharge

Parameter	Test Method and Conditions	Conditions / Sample size	Evaluation Standard
Resistance to ESD IEC61000-4-2 Level 4 (SPR c 2.5.1)	Level 4: contact +/- 8kV, air +/- 15kV	10 exposures on each polarity / 5 units DUT Power off	All samples fully operable. All acoustical parameters according specification with tolerances increased by 50%.



2403 260 00071

5. Related Documents

IEC 268-5	Sound System equipment Part 5: Loudspeaker
IEC 68-2	Environmental testing
EN 60068-2	Environmental testing
ISO 2859 - 1	Sampling procedures for inspection by attributes Part 1: Sampling plans indexed by acceptable quality level (AQL) for lot-by-lot inspection
ISO 3951	Sampling procedures and charts for inspection by variables for percent defectives.
ETS 300 019-2-1	Specification of environmental test: Storage Test spec. T 1.2: Weather protected, not temperature controlled storage locations
ETS 300 019-2-2	Specification of environmental test: Transportation Test spec. T 2.3: Public Transportation
ETS 300 019-2-5	Specification of environmental test: Ground vehicle installations Test spec. T 5.1: Protected installation
ETS 300 019-2-7	Specification of environmental test: Portable and non-stationary use Test spec. T 7.3E: Partly weather protected and non-weather protected locations

6. Additional documents

1) Packaging information

9922 580 12511 Standard packing and barcode label description

2) Application Note

t.b.d.

3) Handling Instruction

9922 580 13271



2403 260 00071

7. Change History

Status	Version	Date	ECR	Comment / Changes	Initials of owner
Obsolete	A	01.06.11	3152	First Release	AH/CS/CP
Release	B	06.12.12	3898	THD below 300Hz; SPL frequency response limits adapted, Sensitivity wider, overshoot, Removed requirement for Nickel coating, Plate material removed, name adapted	OL/EP/MB/CP

8. Disclaimer

Stresses above the Absolute Maximum Ratings may cause permanent damage to the device. These are stress ratings only. The device may not function when operated at these or any other conditions beyond those indicated under “Electrical and Acoustical Specifications”. Exposure beyond those indicated under “Electrical and Acoustical Specifications” for extended periods may affect device reliability.

This product is not qualified for use in automotive applications

Frequency range for telecom use

The information contained in this literature is based on our experience to date and is believed to be reliable and it is subject to change without notice. It is intended as a guide for use by persons having technical skill at their own discretion and risk. We do not guarantee favorable results or assume any liability in connection with its use. Dimensions contained herein are for reference purposes only. For specific dimensional requirements consult factory. This publication is not to be taken as a license to operate under, or recommendation to infringe any exiting patents. This supersedes and voids all previous literature.

