



Chipsmall Limited consists of a professional team with an average of over 10 year of expertise in the distribution of electronic components. Based in Hongkong, we have already established firm and mutual-benefit business relationships with customers from,Europe,America and south Asia,supplying obsolete and hard-to-find components to meet their specific needs.

With the principle of “Quality Parts,Customers Priority,Honest Operation,and Considerate Service”,our business mainly focus on the distribution of electronic components. Line cards we deal with include Microchip,ALPS,ROHM,Xilinx,Pulse,ON,Everlight and Freescale. Main products comprise IC,Modules,Potentiometer,IC Socket,Relay,Connector.Our parts cover such applications as commercial,industrial, and automotives areas.

We are looking forward to setting up business relationship with you and hope to provide you with the best service and solution. Let us make a better world for our industry!



## Contact us

Tel: +86-755-8981 8866 Fax: +86-755-8427 6832

Email & Skype: info@chipsmall.com Web: www.chipsmall.com

Address: A1208, Overseas Decoration Building, #122 Zhenhua RD., Futian, Shenzhen, China



## SPEAKER-1318-4.5-SC-SAMBO-WP

The 13x18x4.5 mm SAMBO-WP is an advanced miniature speaker of rectangular shape, specifically designed for waterproof applications in smartphones and multimedia devices where high sound pressure levels and quality sound are required.

All materials used on the top surface of the speaker are tested to be water resistant.

100% leak measurement guarantees IPx8 waterproof compliance.

In addition to waterproof compliance this component provides the same performance as the standard SAMBO speaker device (available under part number 2403 260 00058).



### Features:

- IPx8 waterproof tested in 1.5m for 30min.
- Waterproof compliance 100% tested for each single speaker device
- Loudest speaker in 13x18 footprint with 94.5dB SPL@700mW
- Compound membrane for minimum THD, Q-factor and tumbling, and high power handling capacity
- Fully-automated manufacturing
- Pre-loaded springs for mechanical robustness and easy handling
- 100% in-line measurement of specified acoustical and electrical parameters

## Contents

1.	Theory of operation.....	3
2.	Mechanical layout and dimensions.....	4
2.1.	Main dimensions .....	4
2.2.	PWB layout & electric polarity .....	5
2.3.	Spring force .....	6
2.4.	HNO3 test area .....	7
2.5.	Part marking / labeling .....	8
2.6.	Force on component .....	9
2.7.	Water/gas tightness .....	10
2.8.	Material list.....	10
3.	Electrical and acoustical specifications .....	11
3.1.	Frequency response .....	11
3.2.	Electro-Acoustic parameters .....	13
3.3.	Power handling.....	13
3.4.	Measurement setup .....	14
3.5.	Measured Parameters .....	14
3.6.	Measurement adapter .....	15
4.	Environmental Conditions.....	16
4.1.	Storage.....	16
4.2.	Transportation.....	16
4.3.	Functionality.....	16
5.	Environmental tests .....	17
5.1.	Qualification tests.....	17
5.2.	Reliability tests .....	17
5.3.	Sample Size, Sequence .....	17
5.4.	Period of Shelf-Life .....	17
5.5.	Testing Procedures.....	17
6.	Related Documents .....	21
7.	Change History .....	22
8.	Disclaimer .....	22



2403 260 00133

## 1. Theory of operation

SPEAKER-1318-4.5-SC-SAMBO-WP is an electrodynamic transducer, designed to translate electrical analog signals into acoustic waves. The input signal is fed into a coil which is exposed to a permanent magnetic field and where a membrane is attached to. Through the principle of the resulting electromagnetic force, the membrane is moved according to the contents of the input signal and thus emitting sound by the air shifted.

# 2403 260 00133

## 2. Mechanical layout and dimensions

### 2.1. Main dimensions

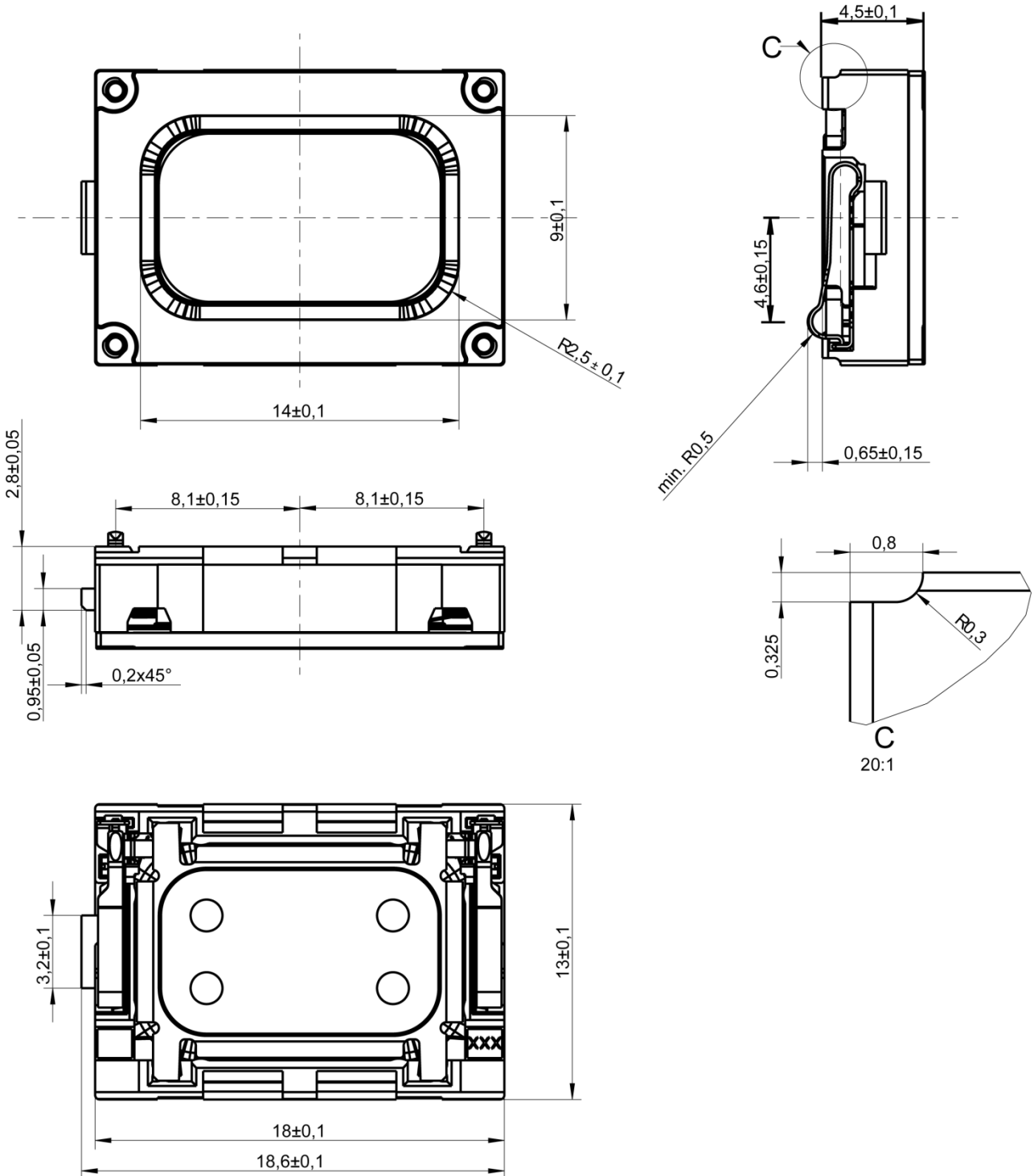

# 2403 260 00133

## 2.2. PWB layout & electric polarity

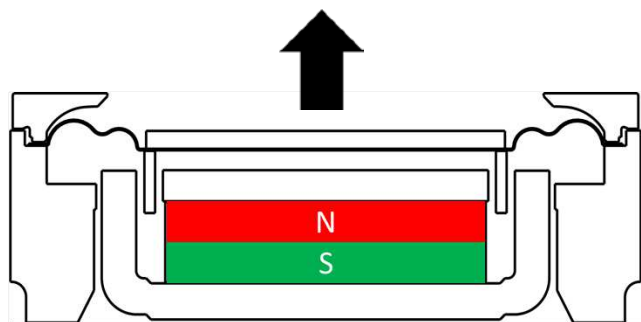
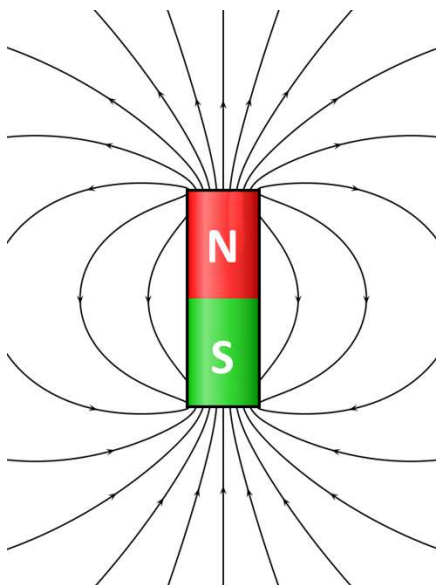
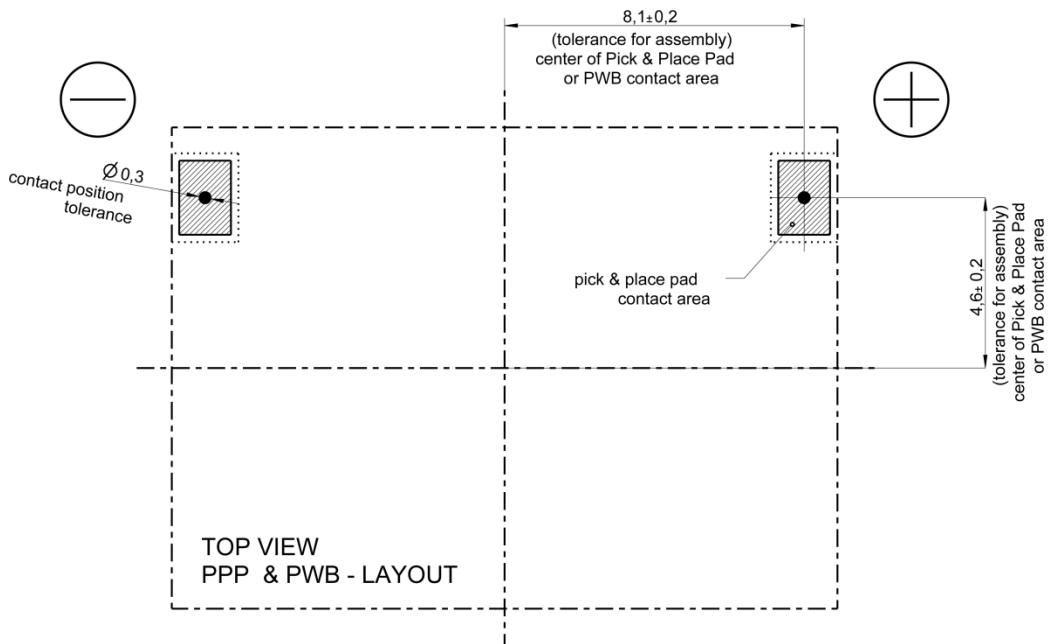

Positive voltage on pin +  
 Moves the membrane in direction of arrow

## 2.3. Spring force

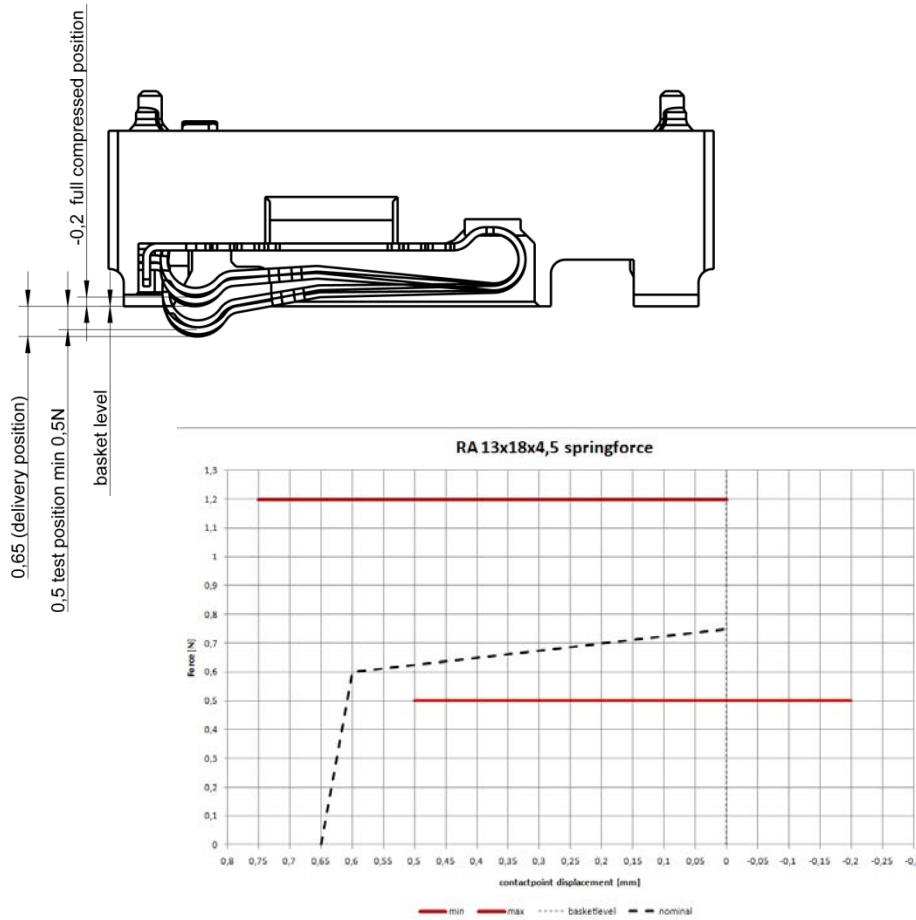

SPRING FORCE TABLE		
Force at basket level	0 mm	max 1.2 N
Force at start working position	0.5 mm	min 0.5N
uncompressed (delivery position)	0.65 +/- 0.15mm	0 N
Force at PPP level	-0.2 mm	max 1.2 N

### 2.3.1. Test method

- Test speed V=10mm/min
- Load contact spring 2x to basket level (0mm)
- The min. contact spring force shall be measured at test position (0.5mm) (second backwards stroke of diagram)
- Load contact spring to full compressed (-0.2mm) and measure max. contact spring force

2403 260 00133

2.4. HNO3 test area

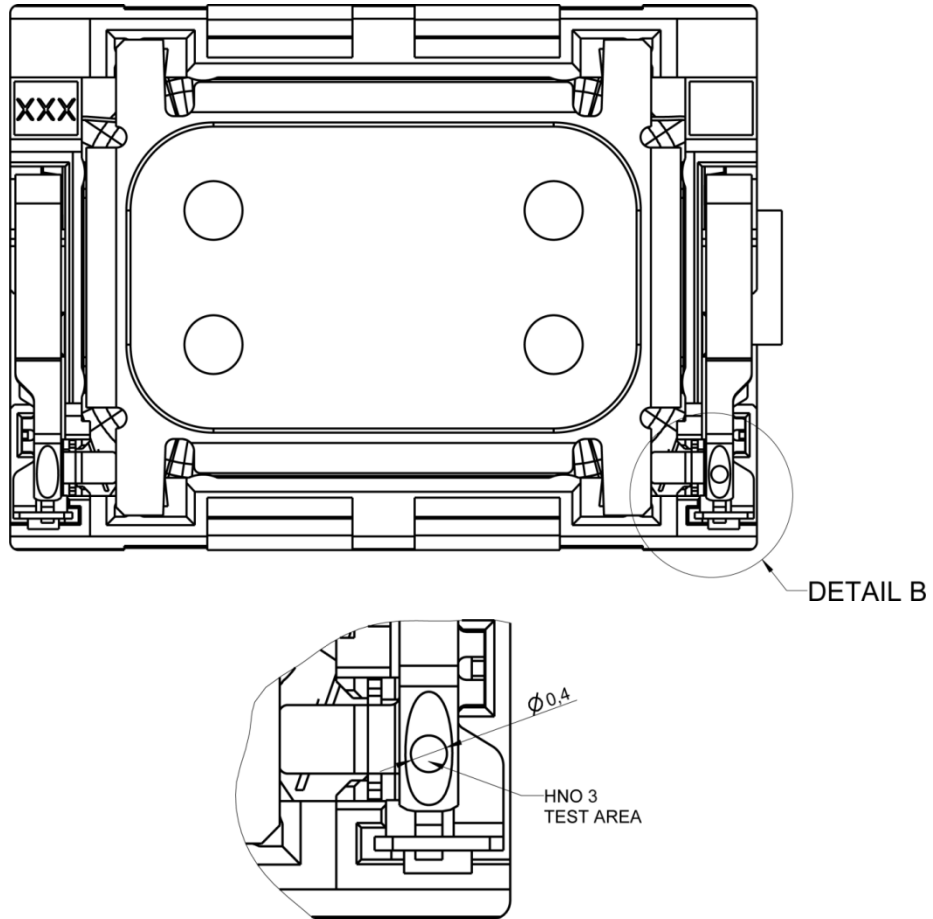



# 2403 260 00133

## 2.5. Part marking / labeling

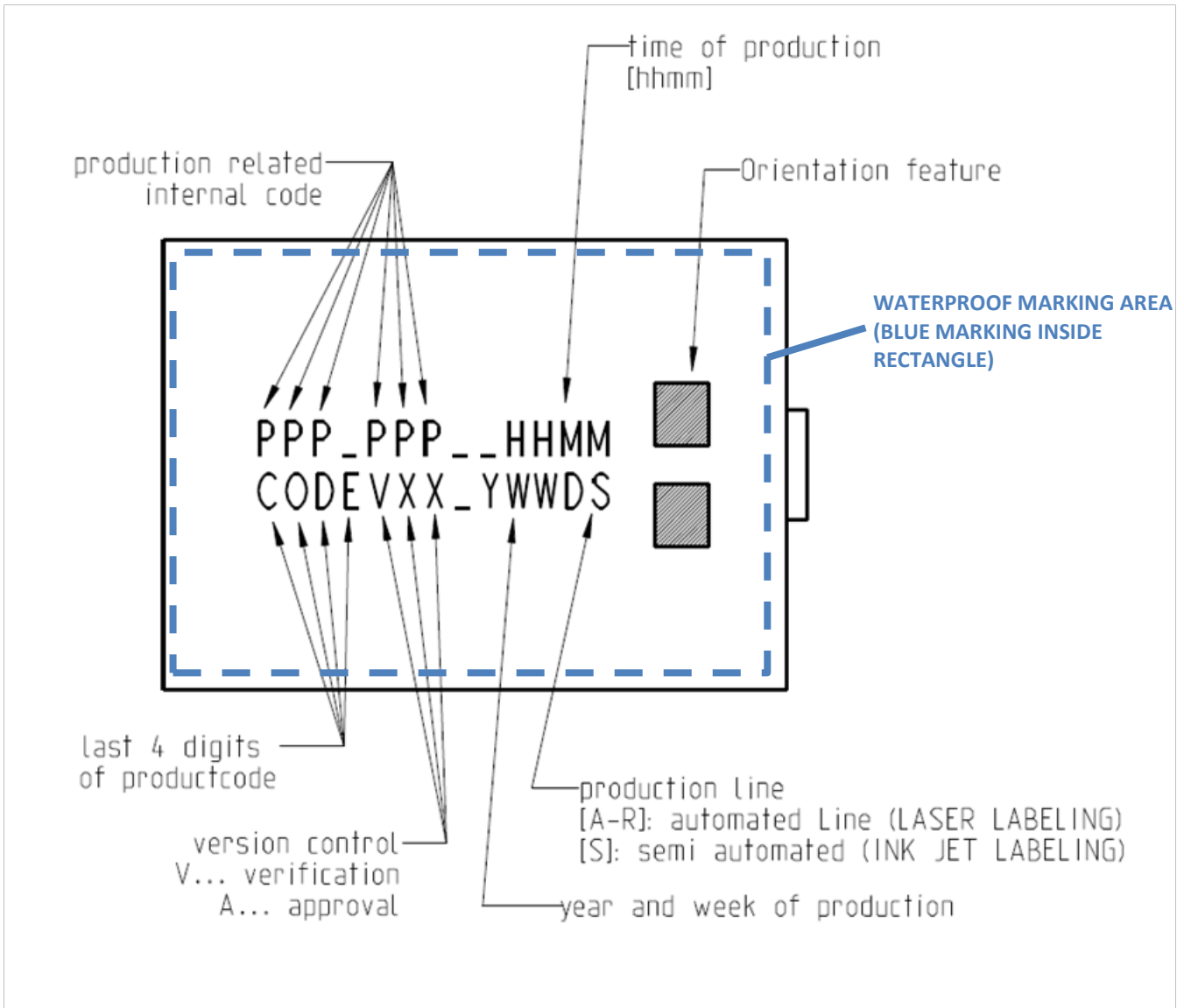

# 2403 260 00133

## 2.6. Force on component

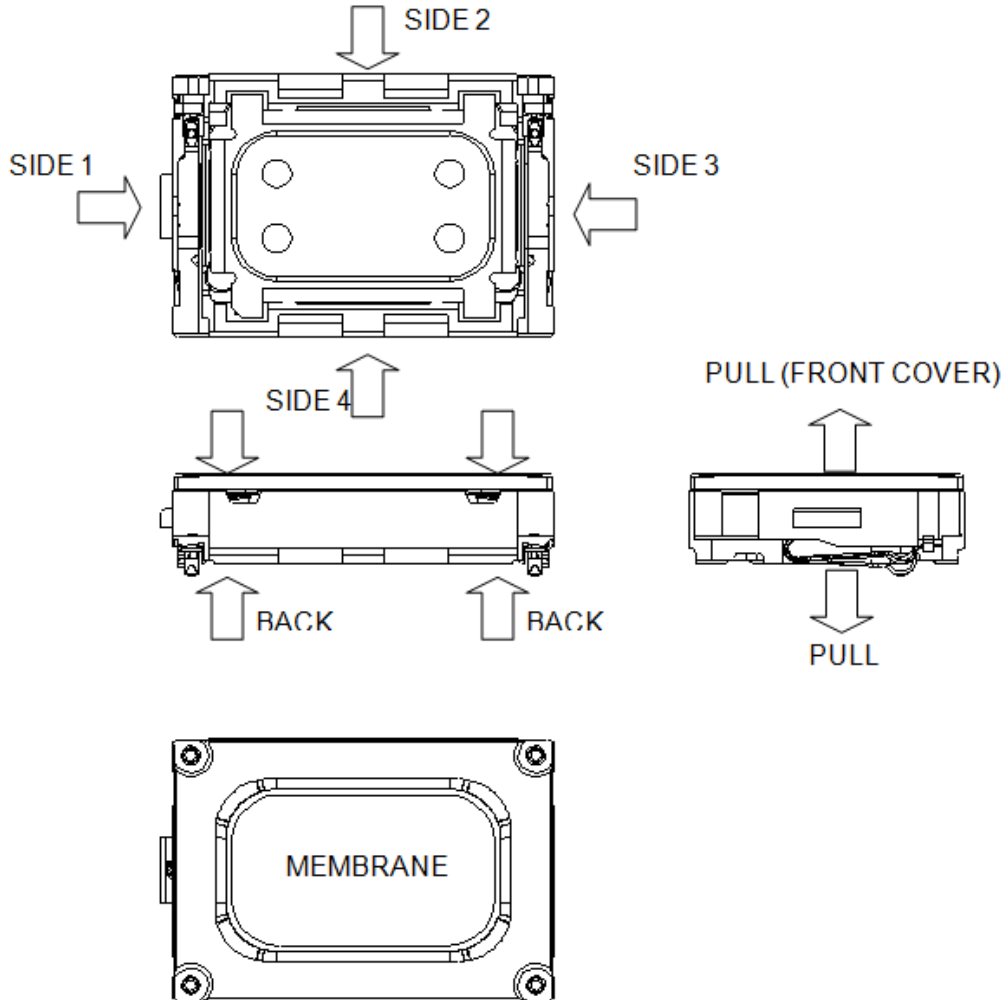

FORCES ON DIFFERENT STATE OF COMPONENT			
STATE	MIN.SURFACE OF PRESSURE [mm <sup>2</sup> ]	MAX. PERMANENT FORCE [N]	MAX. HANDLING FORCE [N]
FROM FRONT TO BACK	-	10	15
FROM SIDE 1 TO SIDE 3	3	10	15
FROM SIDE 2 TO SIDE 4	10	10	15
TO POT	-	3	10
TO MEMBRANE	-	0	0
PULL OF FORCE	-	0	5

2403 260 00133

## 2.7. Water/gas tightness

The products are 100% tested for leaks between cover and membrane.

Method: Differential pressure measurement

Down force on cover:> 5N

Allowed leakage < 3cm<sup>3</sup>/minute.

## 2.8. Material list

- |                          |                            |
|--------------------------|----------------------------|
| 1. Material of basket:   | Polycarbonate bromide free |
| 2. Material of membrane: | Polyarylate-Compound       |
| 3. Material of pot:      | soft magnetic Iron         |
| 4. Material of magnet:   | Nd Fe B                    |
| 5. Material of contact   | CrNi-Steel gold plated     |
| 6. Material of cover:    | Polycarbonate transparent  |
| 7. Dimensions (in mm):   | 18x13x4.5                  |
| 8. Mass:                 | 2.51g                      |

# 2403 260 00133

## 3. Electrical and acoustical specifications

### 3.1. Frequency response

#### 3.1.1. Frequency response with 1cm<sup>3</sup> back cavity

Typical frequency response measured on baffle according to chapter 2.6 (distance d = 1cm, P = 700mW, with 1cm<sup>3</sup> back cavity)

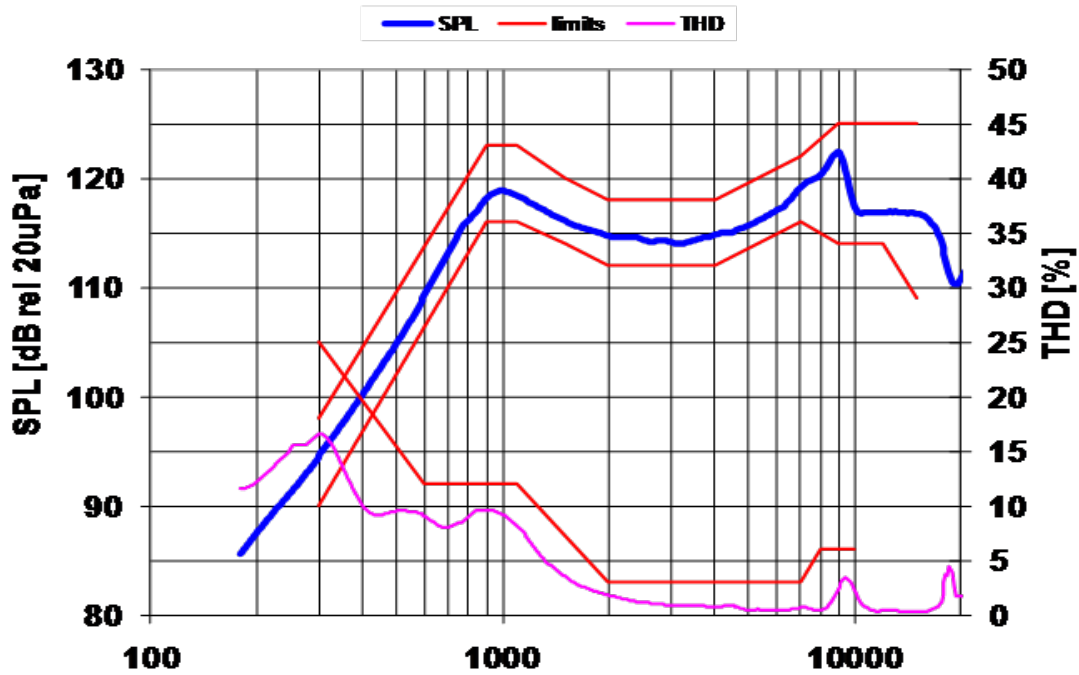

Frequency Response Tolerance window				
SPL			THD	
f [Hz]	lower limit [dB SPL]	upper limit [dB SPL]	f [Hz]	upper limit [%]
300	90	98	300	25
850	116	123	600	12
950	116	123	1100	12
1100	116	123	2000	3
1500	114	120	7000	3
2000	112	118	8000	6
4000	112	118	10000	6
7000	116	122		
9000	114	125		
12000	114	125		
15000	109	125		

# 2403 260 00133

### 3.1.2. Frequency response without back cavity

Typical frequency response measured on baffle according to chapter 2.6 (distance  $d = 1\text{cm}$ ,  $P = 125\text{mW}$ , without back cavity)

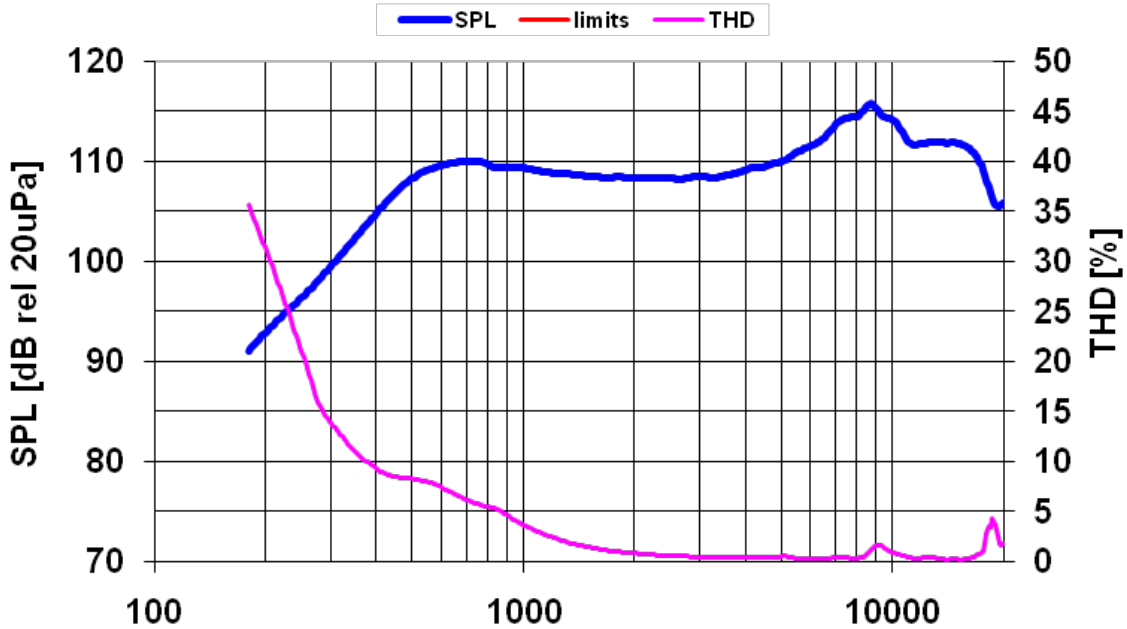

### 3.1.3. Membrane excursion

Typical membrane excursion without back cavity ( $P = 125\text{mW}$ ) and with  $1\text{cm}^3$  back cavity ( $P = 700\text{mW}$ )

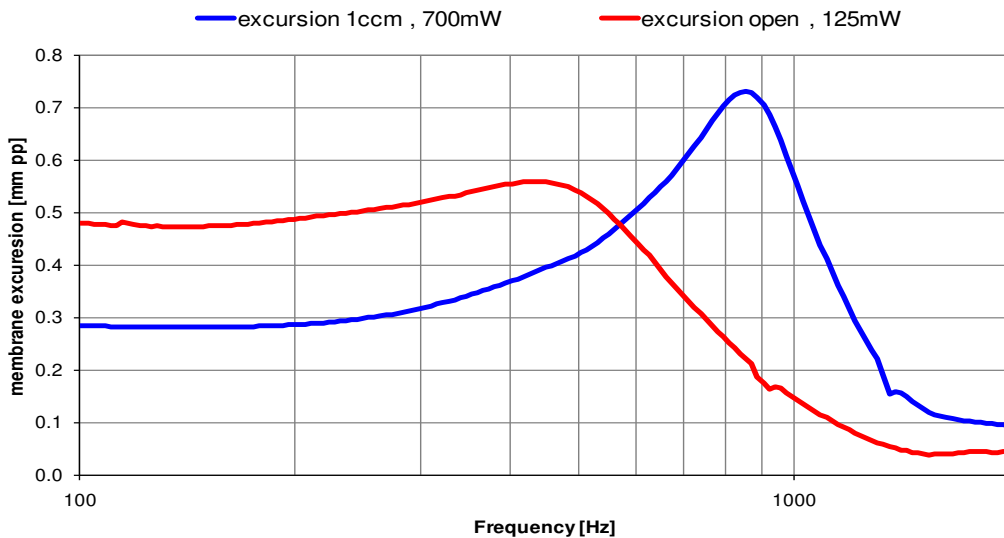



# 2403 260 00133

## 3.2. Electro-Acoustic parameters

Loudspeaker mounted in adapter acc. to 3.6.

1. Rated impedance	Z:	8Ω
2. Voice coil resistance	R:	7.2Ω±10%
3. Resonance frequency (measured @1cm <sup>3</sup> , 700mW)	f <sub>0</sub> :	900Hz±7,5%
3.1. Typical resonance frequency (measured @ open back, 100mW)	f <sub>0</sub> :	500Hz±18%
4. Maximum usable excursion (peak-to-peak)	X <sub>max</sub> :	0.75 mm <sub>p-p</sub>
5. Nominal characteristic sensitivity (calculated for 1W in 1m) average from 2kHz to 4kHz		76±2dB
5.1. Measured characteristic sensitivity (at 700mW in 1cm) average from 2kHz to 4kHz		114.5±2dB
6. THD	according chapter 3.1.	
7. Rub & buzz measured @ 10cm, 1cm <sup>3</sup> , 700mW (2.37V <sub>eff</sub> )	< 65dB SPL (300Hz -1500Hz)	

All acoustic measurements at 23±2°C

## 3.3. Power handling

Loudspeaker mounted in lifetime test device (1cm<sup>3</sup> back cavity, open front)

1. Max short term power (pink noise, 2 <sup>nd</sup> order high-pass filtered, -3dB at 1.2kHz, crest factor 2)	(1sec. ON / 60sec. OFF)	1000mW (RMS)
2. Max continuous power (pink noise, 2 <sup>nd</sup> order high-pass filtered, -3dB at 900Hz, crest factor 2)	(500h)	700mW (RMS)



### 3.4. Measurement setup

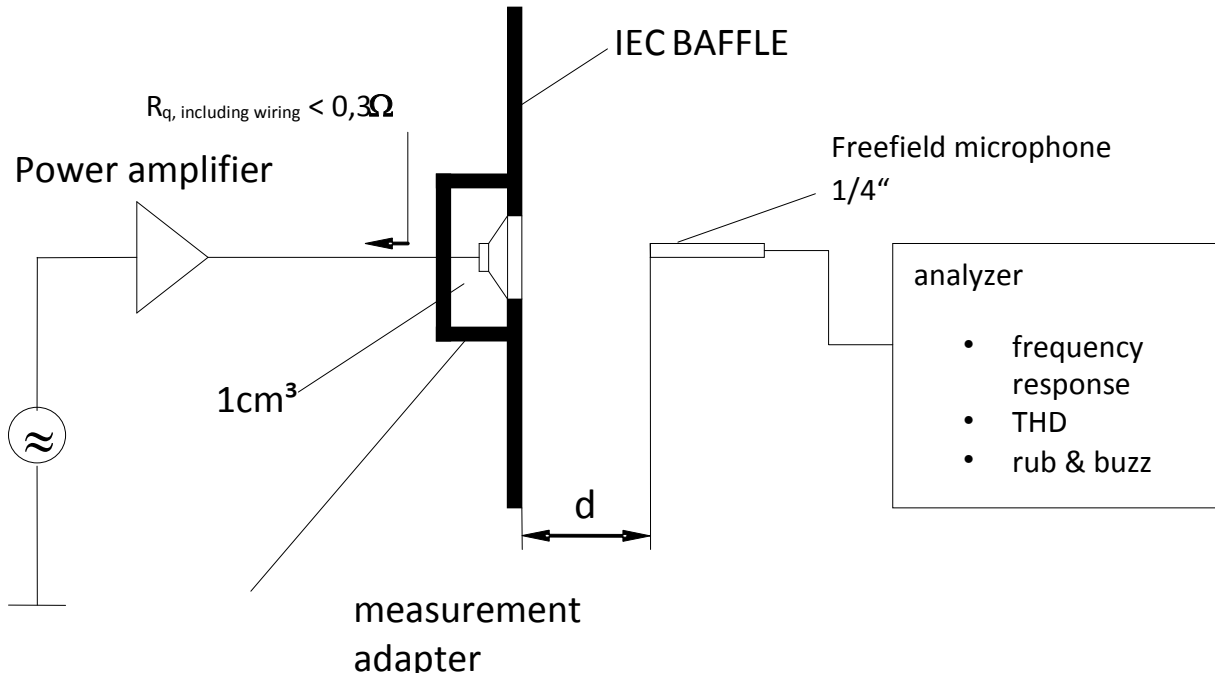

### 3.5. Measured Parameters

#### 3.5.1. Sensitivity

SPL is expressed in dB rel  $20\mu\text{Pa}$ , computed according to IEC 268-5.

Measurement set up and parameters according chapter 3.4.

This test is performed for 100% of products in the production line.

#### 3.5.2. Frequency response

Frequency response is measured according test set up in chapter 3.4 data sheet and checked against the tolerance window defined in chapter 3.1. This Test is performed for 100% of products in the production line.

#### 3.5.3. Total harmonic distortion (THD)

Is measured according IEC 268-5 (2nd to 5th harmonics) and test set up in chapter 3.4. This test is performed for 100% of products in the production line.

#### 3.5.4. Rub & Buzz

Rub & Buzz will be measured in the Inline-measuring device with a sinusoidal sweep. Rub & Buzz is defined as the maximum level of no harmonic energy, expressed as signal to non-harmonic content ratio, in a certain frequency-range. Signal and evaluation criteria are according to chapter 3.2. This test is performed for 100% of products in the production line.

# 2403 260 00133

## 3.6. Measurement adapter

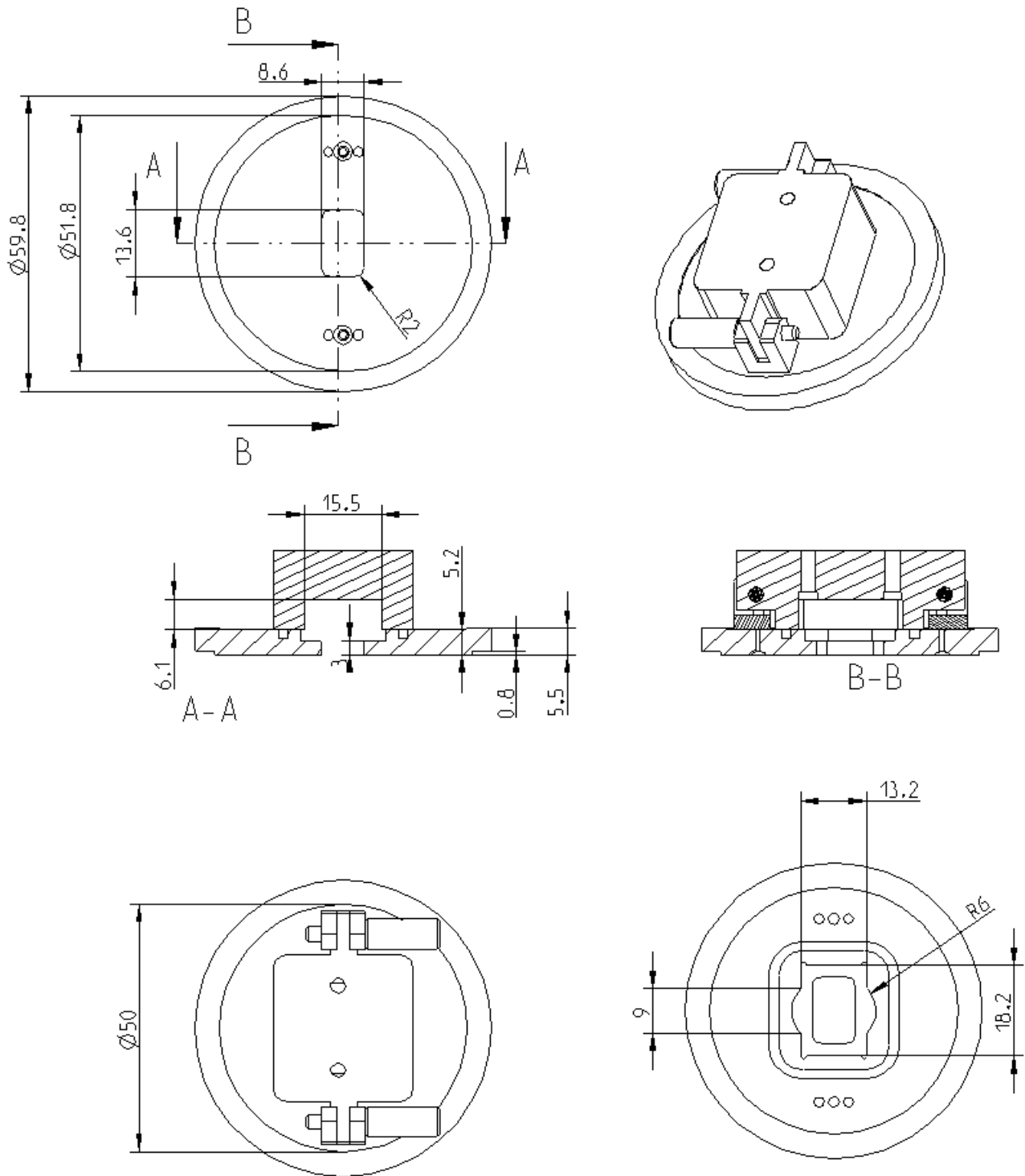

2403 260 00133

## 4. Environmental Conditions

### 4.1. Storage

The transducer fulfills the specified data after treatment according to the conditions of

**ETS 300 019-2-1**                      Specification of environmental test: Storage  
Test spec. T 1.2: Weather protected, not temperature controlled storage locations.

### 4.2. Transportation

The transducer fulfills the specified data after treatment according to the conditions of

**ETS 300 019-2-2**                      Specification of environmental test: Transportation  
Test Spec. T 2.3: Public Transportation

### 4.3. Functionality

The transducer fulfills the specified data after treatment according to the conditions of

**ETS 300 019-2-5**                      Specification of environmental test: Ground vehicle installations  
Test spec. T 5.1: Protected installation

**ETS 300 019-2-7**                      Specification of environmental test: Portable and non-stationary use  
Test spec. T 7.3E: Partly weather protected and non-weather protected locations.

## 5. Environmental tests

### 5.1. Qualification tests

According to our milestone plan (Product Creation Process), a complete qualification test will be done at design validation of products manufactured under serial conditions.

1x per year and product family a requalification takes place. The qualification process covers all tests described under 5.5 and a complete inspection.

### 5.2. Reliability tests

1x per month and product family samples are taken and submitted to tests described under 5.5.2

### 5.3. Sample Size, Sequence

Unless otherwise stated 20 arbitrary new samples will be used to perform each test for both, qualification and requalification test as described under 5.1 and 5.2.

### 5.4. Period of Shelf-Life

The period of shelf-life is 2 years.

### 5.5. Testing Procedures

#### 5.5.1. Storage Tests

##### 5.5.1.1. Low Temperature Storage Test

Parameter	Test Method and Conditions	Duration	Evaluation Standard
Low Temperature Storage (Ref. EN 60068-2-1)	-40°C rel. humidity not controlled	168h	Measurements after 2 hours recovery time. All samples fully operable. All acoustical parameters according specification with tolerances increased by 50 %.

##### 5.5.1.2. High Temperature Storage Test

Parameter	Test Method and Conditions	Duration	Evaluation Standard
Dry Heat Storage (Ref. EN 60068-2-2)	+85°C rel. humidity not controlled	168h	Measurements after 2 hours recovery time. All samples fully operable. All acoustical parameters according specification with tolerances increased by 50 %.



# 2403 260 00133

### 5.5.1.3. Temperature Cycle Test

Parameter	Test Method and Conditions	Duration	Evaluation Standard
Change of Temperature (Ref. EN 60068-2-14)	-40°C/+85°C Transition time <3 min. See Figure 5-1 below	5 cycles >2h for each temperature	Measurements after 2 hours recovery time. All samples fully operable. All acoustical parameters according specification with tolerances increased by 50 %.

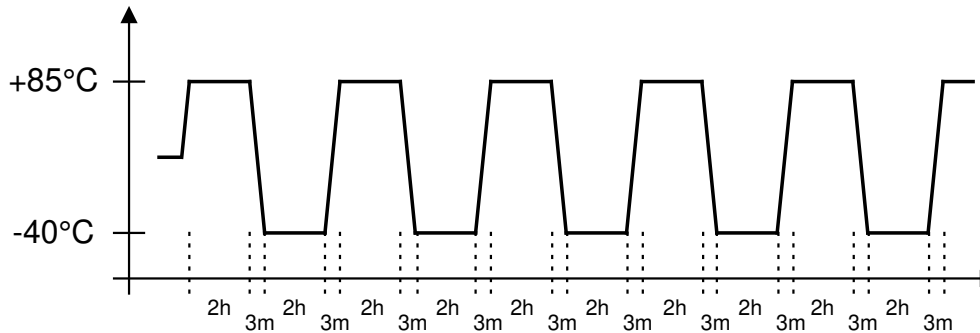

Figure 5-1: Temperature Cycle Test

### 5.5.1.4. Temperature / Humidity Cycle Test

Parameter	Test Method and Conditions	Duration	Evaluation Standard
Damp heat, cyclic (Ref. IEC 60068-2-30)	+25°C/+55°C 90% to 95% RH. Temp. change time <3h See Figure 5-2 below <u>Caution:</u> no condensed water on products!	6 cycles. 24h at each temperature	Measurements after 2 hours recovery time. All samples fully operable. All acoustical parameters according specification with tolerances increased by 50 %.

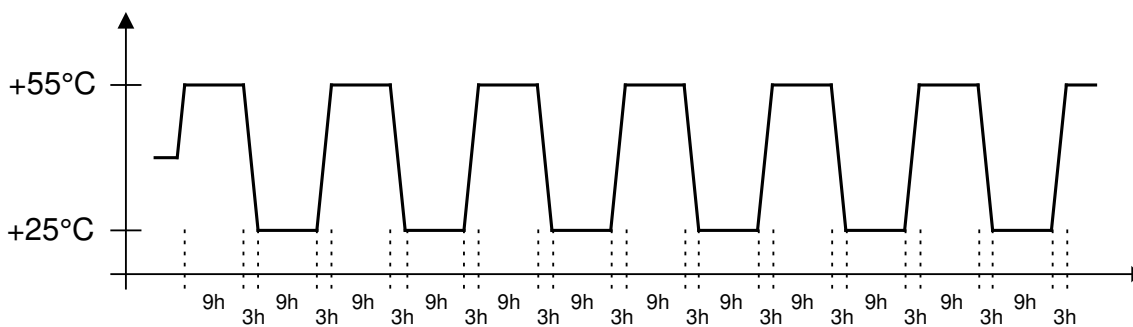

Figure 5-2: Temperature / Relative Humidity Cycle Test

## 5.5.2. Operating Tests

### 5.5.2.1. Cold Operation Test

Parameter	Test Method and Conditions	Duration	Evaluation Standard
Cold Operation Test (Ref. EN 60068-2-1)	-20°C rel. humidity not controlled signal acc. chapter 3.3	72h	Measurements after 2 hours recovery time. All samples fully operable. THD may be increased after test. All other acoustical parameters according specification with tolerances increased by 50 %.

### 5.5.2.2. Dry Heat Operation Test

Parameter	Test Method and Conditions	Duration	Evaluation Standard
Dry Heat Operation (Ref. EN 60068-2-2)	+70°C rel. humidity not controlled signal acc. chapter 3.3	500h	Measurements after 2 hours recovery time. All samples fully operable. The allowable change in sensitivity shall not be greater than 3 dB. All other acoustical parameters according specification with tolerances increased by 50 %.

### 5.5.3. Salt Mist Test

Parameter	Test Method and Conditions	Duration	Evaluation Standard
Salt Mist (Ref. IEC60068-2-52, Kb / Severity 2)	The part must be subjected to 2 hours spray of 5% NaCl salt mist, at 35°C then be left at 40°C and 95% RH for 22h.	3 cycles	The samples shall be washed after the test with distilled water and dried at T < 50°C. Component may have reduced performance, but must still function properly. The allowable sensitivity difference shall not be greater than ±3dB from initial sensitivity.

# 2403 260 00133

## 5.5.4. Shock Resistance Test (Free Fall Test) - unprotected product

Parameter	Test Method and Conditions	Conditions / Sample size	Evaluation Standard
Mechanical shock (Ref. IEC60068-2-32 Ed), Procedure 1	Drop of sample without fixation of release plane from a height of 1.5m onto concrete floor.	Each 3 shocks in both directions of the 3 axes.  (18 drops in total)	Component may have reduced performance, but must still function properly. The allowable sensitivity difference shall not be greater than $\pm 3\text{dB}$ from initial sensitivity.

## 5.5.5. Impact Durability Test (Tumble Test) – protected product

Parameter	Test Method and Conditions	Conditions / Sample size	Evaluation Standard
Impact durability (in a Tumble Tester) (Ref. IEC60068-2-32 Ed) (SPR a7.1.1)	Speaker <i>in drop test box</i> or representative mechanics. Random drops on steel base.	30 units 180 drops, 1m DUT power off	Component may have reduced performance, but must still function properly. The allowable sensitivity difference shall not be greater than $\pm 3\text{ dB}$ from initial sensitivity.

## 5.5.6. Resistance to Electrostatic Discharge

Parameter	Test Method and Conditions	Conditions / Sample size	Evaluation Standard
Resistance to ESD IEC61000-4-2 Level 4 (SPR c 2.5.1)	One pole is grounded and the ESD pulse is applied to the other pole. The speaker must be stressed first with one polarisation and then with the other polarisation. DUT must be discharged between each ESD exposure.  Level 4: contact +/- 8kV, air +/- 15kV	10 exposures on each polarity / 5 units  DUT Power off	All samples fully operable. All acoustical parameters according specification with tolerances increased by 50%.

**5.5.7. Water-resistant**

Parameter	Test Method and Conditions	Conditions / Sample size	Evaluation Standard
Water resistant acc. IPx8 (Ref. IEC60529)	The part must be immersed in 1.5m of water for 30min in a appropriate test adapter.	10 units 1.5m, 30min	No ingress of water through the products allowed. Measurements after samples are dry. All samples fully operable. The allowable change in sensitivity shall not be greater than 3dB. All other acoustical parameters according specification with tolerances increased by 50%.

**6. Related Documents**

- IEC 268-5** Sound System equipment  
Part 5: Loudspeaker
- IEC 68-2** Environmental testing
- EN 60068-2** Environmental testing
- IEC60529** Degrees of protection provided by enclosures (Ingress Protection Code)
- ISO 2859 - 1** Sampling procedures for inspection by attributes  
Part 1: Sampling plans indexed by acceptable quality level (AQL) for lot-by-lot inspection
- ISO 3951** Sampling procedures and charts for inspection by variables for percent defectives.
- ETS 300 019-2-1** Specification of environmental test: Storage  
Test spec. T 1.2: Weather protected, not temperature controlled storage locations
- ETS 300 019-2-2** Specification of environmental test: Transportation  
Test spec. T 2.3: Public Transportation
- ETS 300 019-2-5** Specification of environmental test: Ground vehicle installations  
Test spec. T 5.1: Protected installation
- ETS 300 019-2-7** Specification of environmental test: Portable and non-stationary use  
Test spec. T 7.3E: Partly weather protected and non-weather protected locations

2403 260 00133

## 7. Change History

Status	Version	Date	ECR	Comment / Changes	Initials of owner
Release	A	22.05.2013	4137	First release	MS/GZ/CP

## 8. Disclaimer

Stresses above the Absolute Maximum Ratings may cause permanent damage to the device. These are stress ratings only. The device may not function when operated at these or any other conditions beyond those indicated under “Electrical and Acoustical Specifications”. Exposure beyond those indicated under “Electrical and Acoustical Specifications” for extended periods may affect device reliability.

This product is not qualified for use in automotive applications

Frequency range in telecom application:  
300 Hz – 3.4 kHz

The information contained in this literature is based on our experience to date and is believed to be reliable and it is subject to change without notice. It is intended as a guide for use by persons having technical skill at their own discretion and risk. We do not guarantee favorable results or assume any liability in connection with its use. Dimensions contained herein are for reference purposes only. For specific dimensional requirements consult factory. This publication is not to be taken as a license to operate under, or recommendation to infringe any exiting patents. This supersedes and voids all previous literature.