



Chipsmall Limited consists of a professional team with an average of over 10 year of expertise in the distribution of electronic components. Based in Hongkong, we have already established firm and mutual-benefit business relationships with customers from,Europe,America and south Asia,supplying obsolete and hard-to-find components to meet their specific needs.

With the principle of “Quality Parts,Customers Priority,Honest Operation,and Considerate Service”,our business mainly focus on the distribution of electronic components. Line cards we deal with include Microchip,ALPS,ROHM,Xilinx,Pulse,ON,Everlight and Freescale. Main products comprise IC,Modules,Potentiometer,IC Socket,Relay,Connector.Our parts cover such applications as commercial,industrial, and automotives areas.

We are looking forward to setting up business relationship with you and hope to provide you with the best service and solution. Let us make a better world for our industry!



Contact us

Tel: +86-755-8981 8866 Fax: +86-755-8427 6832

Email & Skype: info@chipsmall.com Web: www.chipsmall.com

Address: A1208, Overseas Decoration Building, #122 Zhenhua RD., Futian, Shenzhen, China



NOTE:

REFERENCE STANDARD IEC60169-4

I. ELECTRICAL PERFORMANCE -

NOMINAL IMPEDANCE : 50 Ω
 FREQUENCY RANGE : DC-3.0 GHz
 VSWR : 1.100 MAX.
 INSERTION LOSS : 0.100 dB MAX. (@ 3.0 GHz)
 PIM : -165 dBc MAX. (2x43dBm)
 INSULATION RESISTANCE : 5000 MΩ MIN.
 D.W.V : 2500 VRMS
 CONDUCTOR RESISTANCE : OUTER CONDUCTOR 0.5 mΩ MAX.
 INNER CONDUCTOR 1.0 mΩ MAX.

II. MECHANICAL PERFORMANCE -

RETENTION : 7/16: 5.88 N MIN. 4.1/9.5: 4.00 N MIN.
 AXIAL FORCE : 200 N
 NUT FORCE : 10 N-m MIN. TO 12 N-m MAX.(4.1/9.5)
 MATING CYCLES : 500 MIN.

III. MATERIAL AND PLATING -

INNER CONDUCTOR : SPRING COPPER ALLOY, PLATING = Ag (5µm MIN.)
 OUTER CONDUCTOR : BRASS, PLATING = COPPER-TIN-ZINC (2µm MIN.)
 NUT : BRASS, PLATING = NI (5µm MIN.)
 INSULATOR : PTFE

IV. ENVIRONMENTAL -

TEMP. RANGE : -40°C TO +85°C
 WEATHER STANDARD : IEC 60068 40/ 85/ 21
 THERMAL SHOCK : MIL-STD 202, METHOD 107, CONDITION B
 VIBRATION : MIL-STD 202, METHOD 204, CONDITION B
 SHOCK : MIL-STD 202, METHOD 213, CONDITION I

V. ROHS COMPLIANT

242278		REVISIONS			
DRAWING NO.	REV	DESCRIPTION	DATE	ECO	APPR
THIRD ANGLE PROJ.	A	RELEASE TO MFG.	11-Sep-13	--	KR/BCG

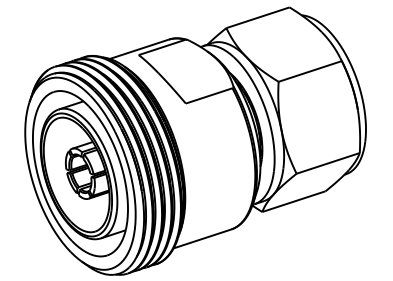

SCALE 1.000

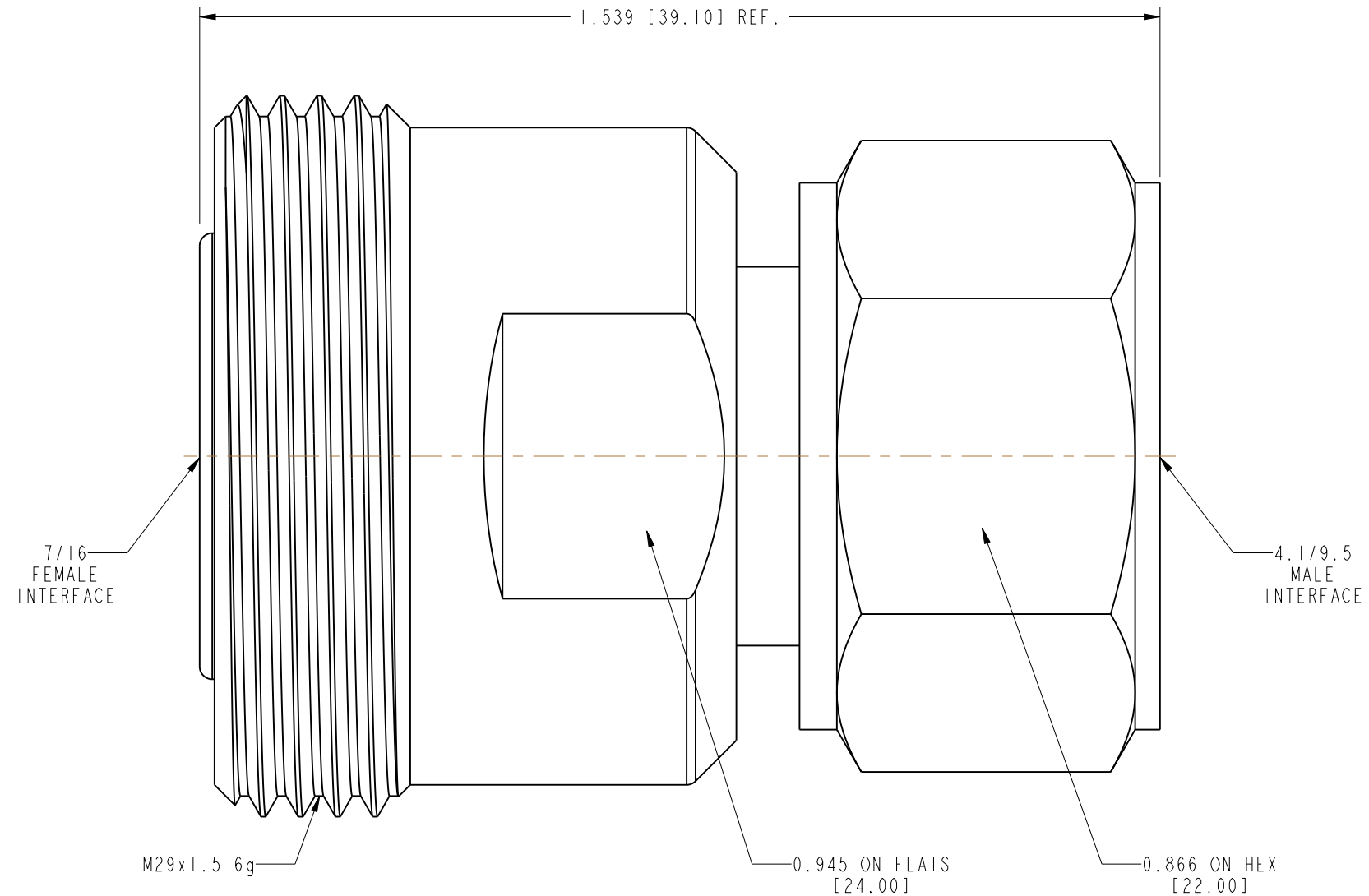

CUSTOMER OUTLINE DRAWING

ALL OTHER SHEETS ARE FOR INTERNAL USE ONLY

UNLESS OTHERWISE SPECIFIED, DIMENSIONS ARE IN INCHES AND TOLERANCES ARE: 2 PLACE DECIMAL ±.015 (0,381 mm) 3 PLACE DECIMAL ±.005 (0,127 mm) ANGLES ± 1°	MATERIAL	DRAWN	DATE	TITLE	Amphenol Connex
	SEE NOTES	KARTHIK R	05-Sep-13	7/16 FEMALE TO 4.1/9.5 MALE ADAPTER	
NOTICE - These drawings, specifications, or other data (1) are, and remain the property of Amphenol Corp. (2) must be returned upon request; and (3) are confidential and not to be disclosed to any person other than those to whom they are given by Amphenol Corp. The furnishing of these drawings, specifications, or other data by Amphenol Corp., or to any other person to anyone for any purpose is not to be regarded by implication or otherwise in any manner licensing, granting rights or permitting such holder or any other person to manufacture, use or sell any product, process or design, patented or otherwise, that may in any way be related to or disclosed by said drawings, specifications, or other data.	REFERENCE	ENGINEER	DATE		
		KARTHIK R	05-Sep-13		
		APPROVED	DATE		
		B.C. GLEISSNER	11-Sep-13		SCALE: 4.0:1 SHEET 1 OF 1
		CAD FILE		DWG SIZE	DRAWING NO.
				B	242278
					REV A