



Chipsmall Limited consists of a professional team with an average of over 10 year of expertise in the distribution of electronic components. Based in Hongkong, we have already established firm and mutual-benefit business relationships with customers from,Europe,America and south Asia,supplying obsolete and hard-to-find components to meet their specific needs.

With the principle of “Quality Parts,Customers Priority,Honest Operation,and Considerate Service”,our business mainly focus on the distribution of electronic components. Line cards we deal with include Microchip,ALPS,ROHM,Xilinx,Pulse,ON,Everlight and Freescale. Main products comprise IC,Modules,Potentiometer,IC Socket,Relay,Connector.Our parts cover such applications as commercial,industrial, and automotives areas.

We are looking forward to setting up business relationship with you and hope to provide you with the best service and solution. Let us make a better world for our industry!



Contact us

Tel: +86-755-8981 8866 Fax: +86-755-8427 6832

Email & Skype: info@chipsmall.com Web: www.chipsmall.com

Address: A1208, Overseas Decoration Building, #122 Zhenhua RD., Futian, Shenzhen, China



used for: D-SUB FILTER

POS.	A -0.76	B -0.25	C	PART-NO.
9	31.19	16.46	25.00 $+0.12$ -0.13	242A17660X
15	39.52	24.79	33.30 $+0.15$ -0.1	242A17670X
25	53.42	38.50	47.04 ± 0.13	242A17680X
37	69.70	54.96	63.50 ± 0.13	242A17690X

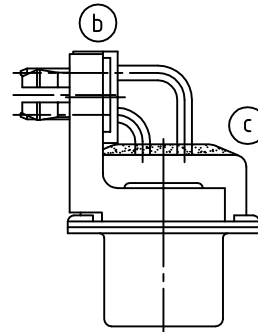
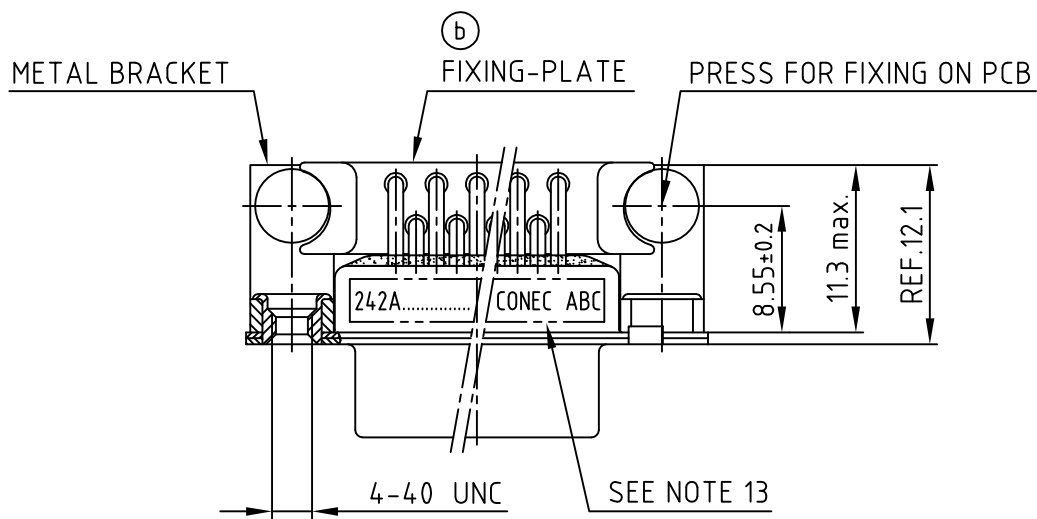
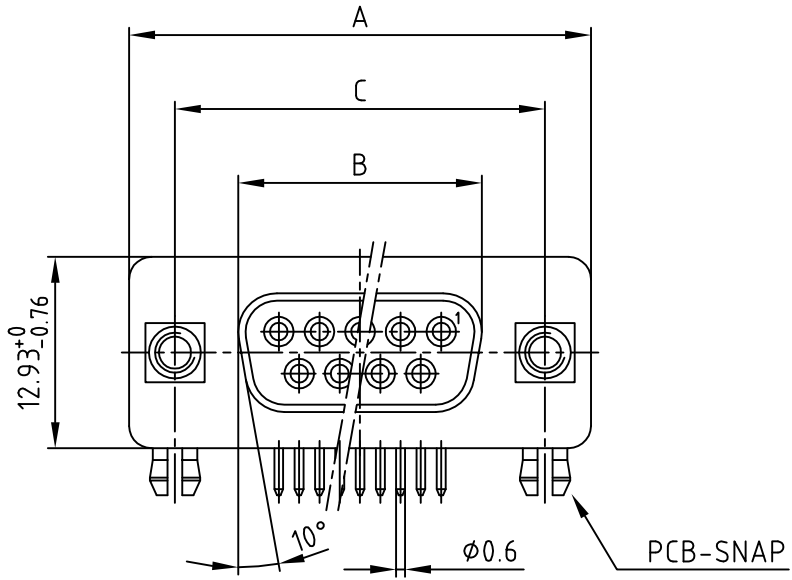
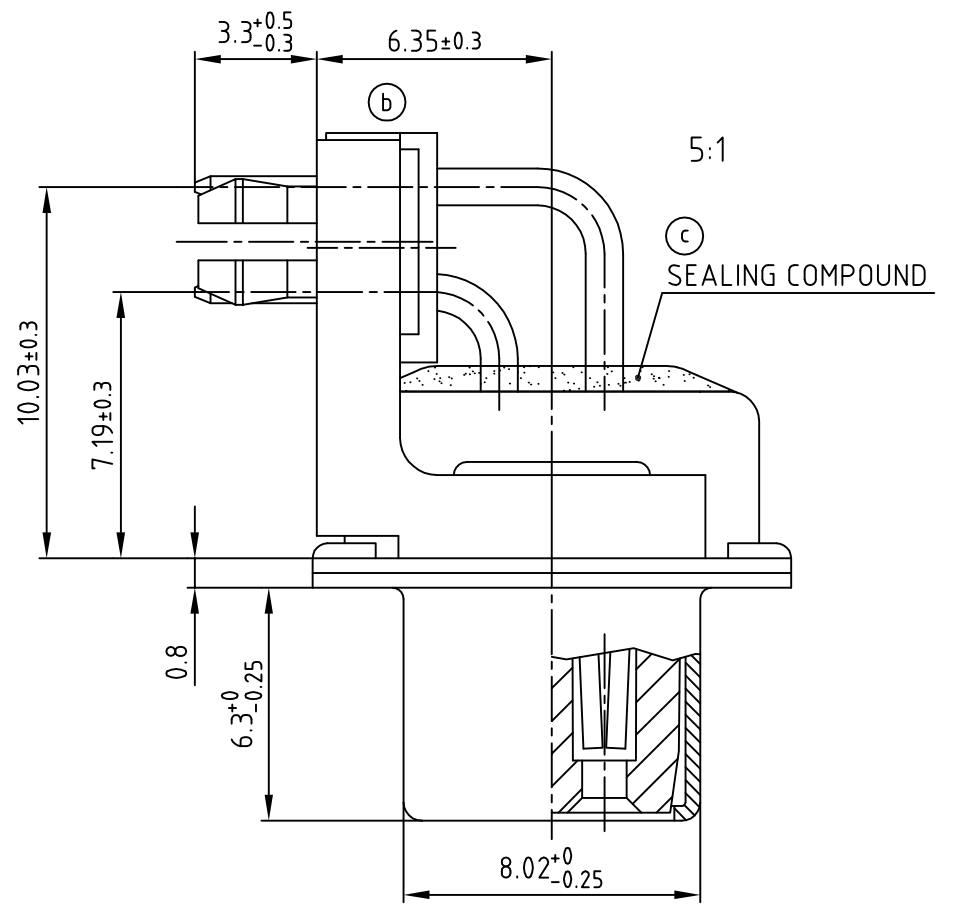

(b) NOTES:

1. RoHS COMPLIANT
2. SUITABLE FOR WAVESOLDERING
3. METAL SHELLS: STEEL; min. 315µm TIN over 40-80µm NICKEL
4. INSULATORS: HIGH TEMPERATURE PLASTIC UL 94 V-0, BLACK
5. CONTACTS: COPPER ALLOY
PLATING: 8µm HARD GOLD OVER min. 50µm NICKEL
6. METAL BRACKET: ZINC DIE CAST; 300µm COPPER/40-120µm NICKEL/120-200µm TIN
7. THREADED INSERT: COPPER ALLOY; min. 200µm TIN over 80µm NICKEL
8. FIXING-PLATE: PBT GF UL 94 V-0, BLACK
9. P.C.B. HOLE DRILLINGS ON SHEET 2
10. CAPACITANCE: 1300pF $\pm 20\%$
11. DIELECTRIC WITHSTANDING VOLTAGE: 424 VDC
12. MAXIMUM TORQUE VALUE FOR THREAD: 6 in.LB
13. CONNECTOR IS PART MARKED: PART-NO. CONEC ABC

Directive 2002/95/EC RoHS compliant

APPROVAL # FREIGABE # DEBLOCAGE # AUTOR/ZACION # APPROVAL	
CUSTOMER APPROVAL DATE:	
NAME:	TITLE:
COMPANY NAME:	
APPROVAL # FREIGABE # DEBLOCAGE # AUTOR/ZACION # APPROVAL	

THIS DRAWING MAY NOT BE COPIED OR REPRODUCED IN ANY WAY, AND MAY NOT BE PASSED ON TO A THIRD PARTY WITHOUT WRITTEN PERMISSION.
OWNERSHIP AND COPYRIGHT OF CONEC GmbH
DO NOT ALTER CAD DRAWING BY HAND

rev.	description	date	name
2 x c	Ä 4000	12.05.2011	Lehmen, d-old
4 x b	Ä 3123	23.09.2008	Lehmen,
a	Original		

tolerance		dim. in mm	scale:	2:1 (5:1)
			material:	SEE NOTES
1997	date	name	title: D-SUB FILTER FEMALE 90° 9-37pos. 0.318inch with threaded insert, metal bracket and snap	
drawn	04.11.	Barcinski		
appd.	04.11.	Mickenbecker		
norm		DIN 41652		dwg no: AutoCAD 2006
CONEC®		24K11W0A		
part no:		SEE TABLE		

DIN-A		3	sh:1/2
-------	--	---	--------

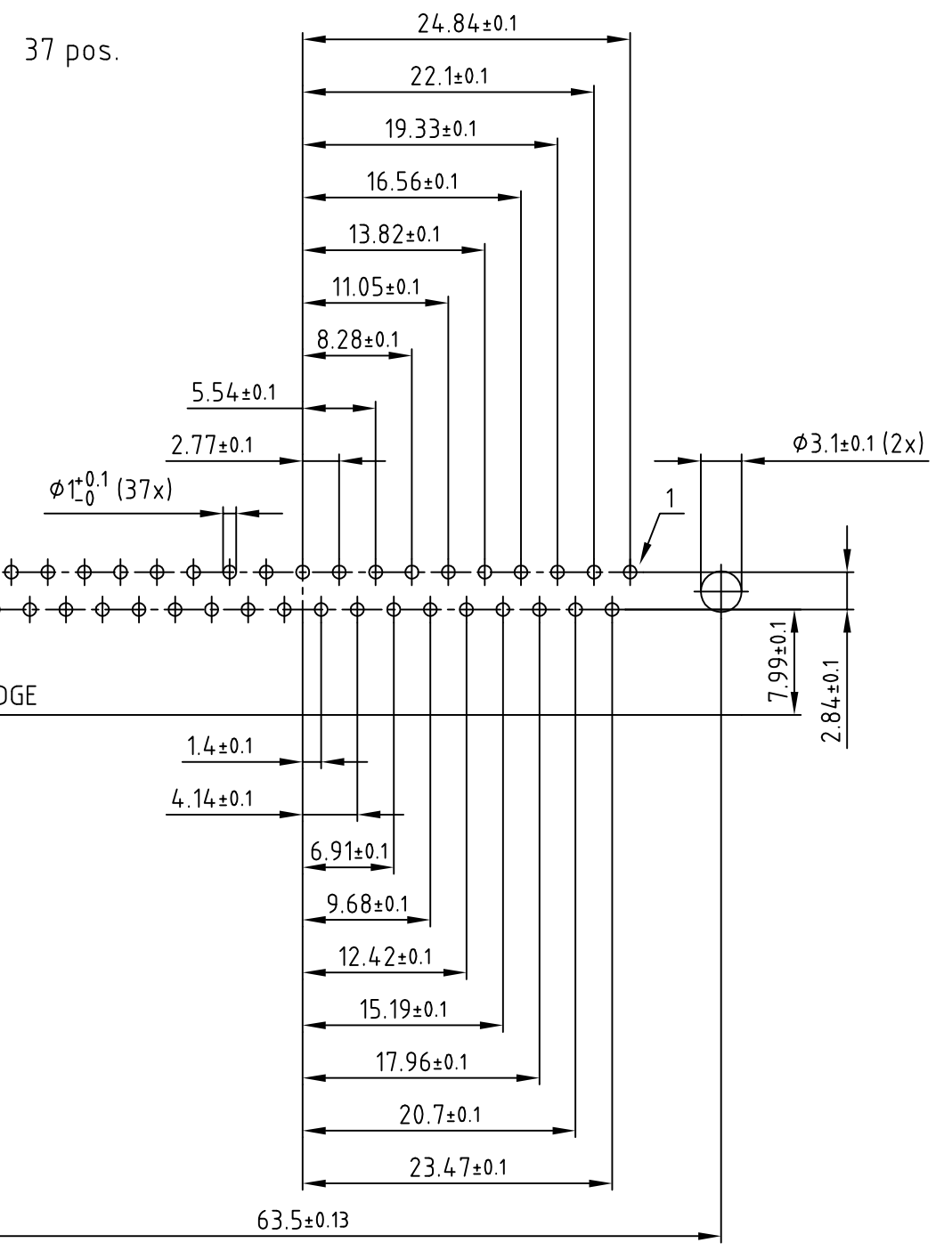
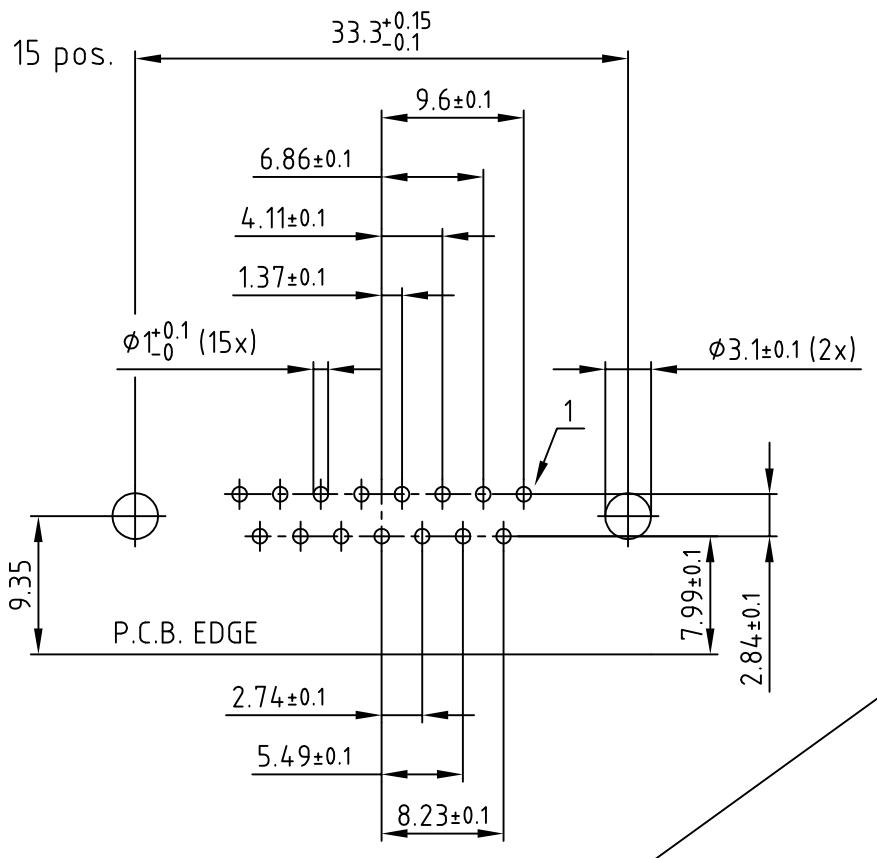
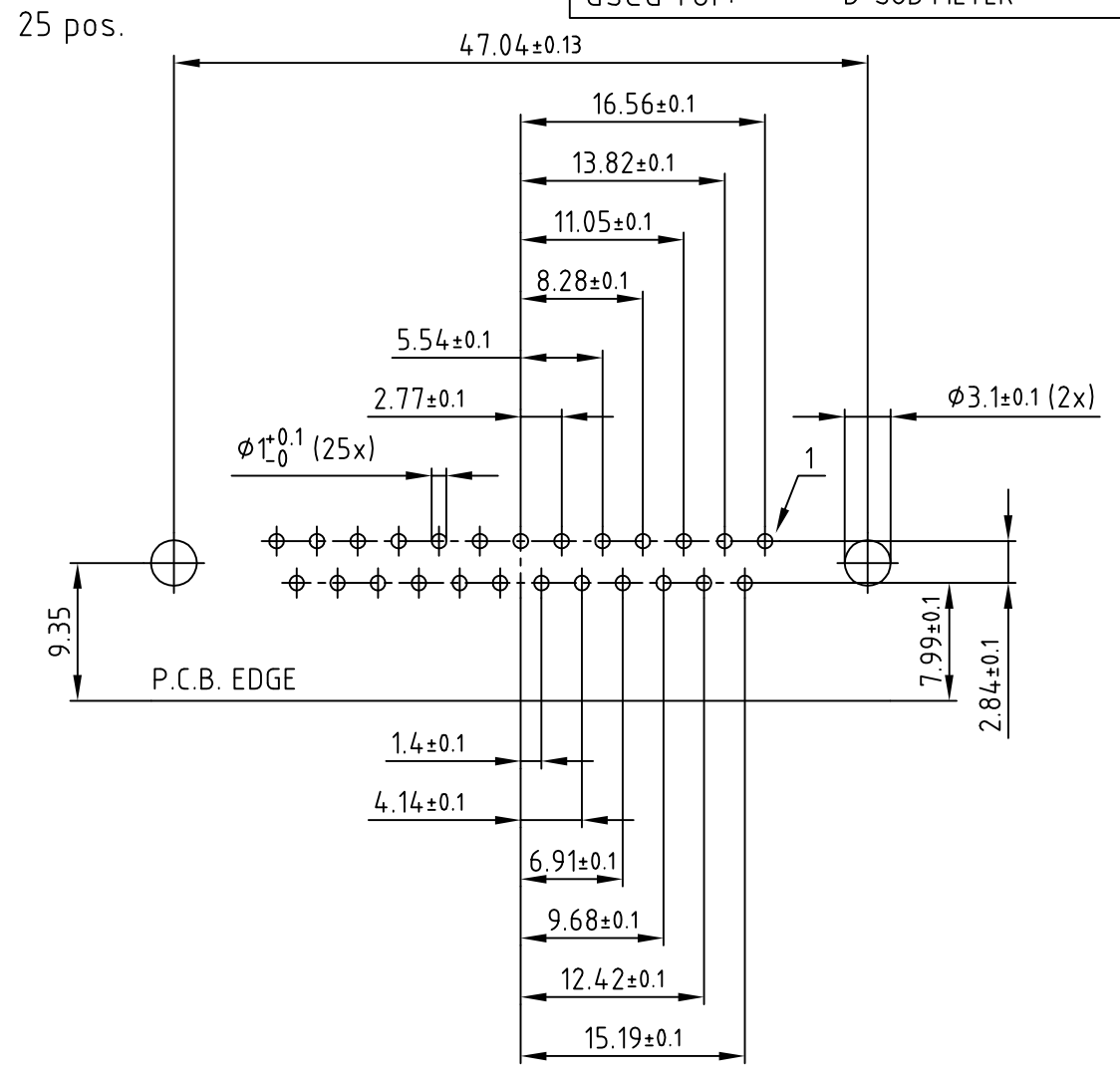
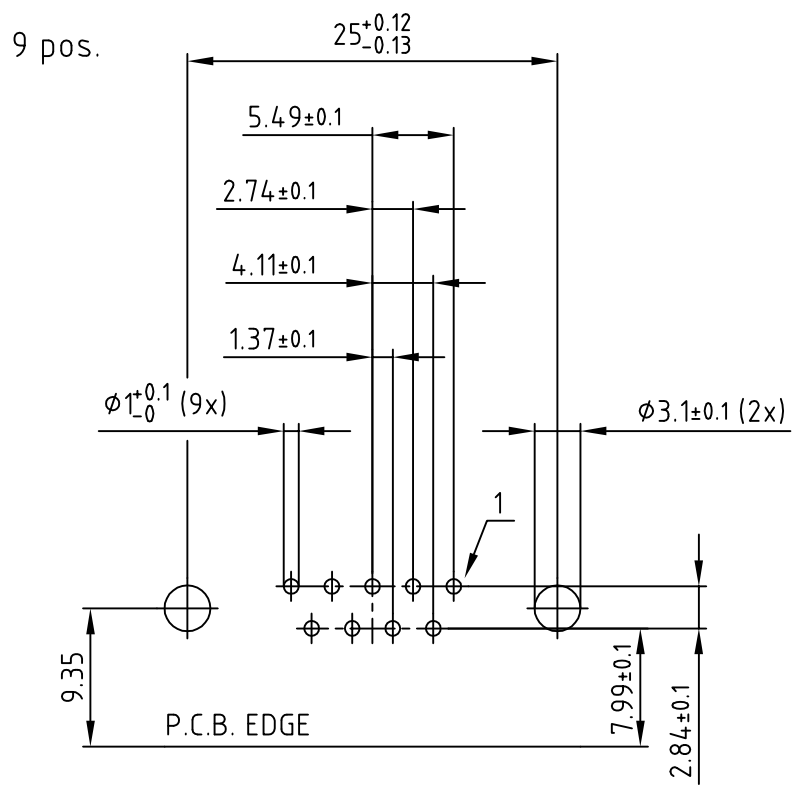

APPROVAL # FREIGABE # DEBLOCAGE # AUTOR/ZACION # APPROVAL

CUSTOMER APPROVAL DATE:

NAME: TITLE:

COMPANY NAME:

APPROVAL # FREIGABE # DEBLOCAGE # AUTOR/ZACION # APPROVAL

THIS DRAWING MAY NOT BE COPIED OR REPRODUCED IN ANY WAY, AND MAY NOT BE PASSED ON TO A THIRD PARTY WITHOUT WRITTEN PERMISSION.

OWNERSHIP AND COPYRIGHT OF CONEC GmbH

DO NOT ALTER CAD DRAWING BY HAND

tolerance		 dim. in mm	scale: 2:1	
			material: SEE SHEET 1	
2008	date	title:		
drawn	23.09.	P.C.B. HOLE DRILLINGS		
appd.	23.09.	D-SUB FILTER FEMALE 90° 9-37pos. 0.318inch with threaded insert, metal bracket and snap		
norm	DIN 41652			
d-old				
a	Original			
rev.	description			

dwg no: AutoCAD 2006

part no: 24K11W0A

SEE SHEET 1

DIN-A 3 sh:2/2