



Chipsmall Limited consists of a professional team with an average of over 10 year of expertise in the distribution of electronic components. Based in Hongkong, we have already established firm and mutual-benefit business relationships with customers from,Europe,America and south Asia,supplying obsolete and hard-to-find components to meet their specific needs.

With the principle of "Quality Parts,Customers Priority,Honest Operation,and Considerate Service",our business mainly focus on the distribution of electronic components. Line cards we deal with include Microchip,ALPS,ROHM,Xilinx,Pulse,ON,Everlight and Freescale. Main products comprise IC,Modules,Potentiometer,IC Socket,Relay,Connector.Our parts cover such applications as commercial,industrial, and automotives areas.

We are looking forward to setting up business relationship with you and hope to provide you with the best service and solution. Let us make a better world for our industry!



Contact us

Tel: +86-755-8981 8866 Fax: +86-755-8427 6832

Email & Skype: info@chipsmall.com Web: www.chipsmall.com

Address: A1208, Overseas Decoration Building, #122 Zhenhua RD., Futian, Shenzhen, China



Solder Instruction

1. Cable should be prepared for soldering. The cable/wires must be pretinned.
2. Insert cable/wire into solder cup
3. Operate the soldering iron at 350°C, 50 Watt max. and use a pencil tip.
4. Apply some solder to the solder tip of the soldering iron.
5. Put tip to wire in solder cup
6. After 1 second bring in solder.
7. Heat for 3 seconds longer. Do not heat contact more than 6 seconds in total.
8. Remove soldering iron.
9. Wait until solder gets rigid again.
10. Do not solder adjacent contacts consecutively, alternate position within the connector to minimize heat build up.

(5:1)

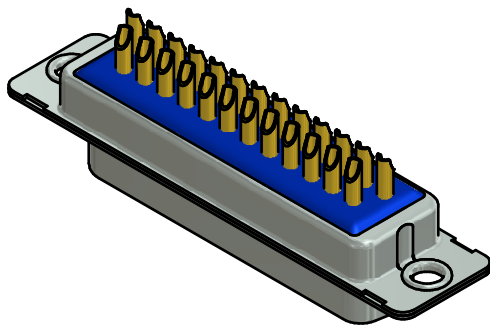
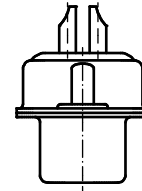
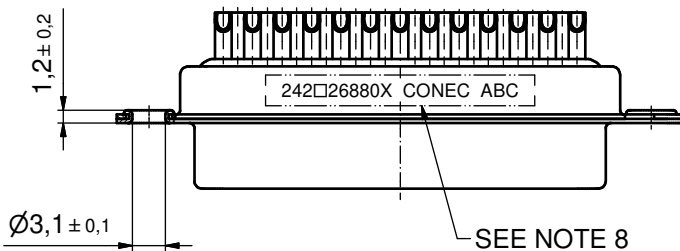
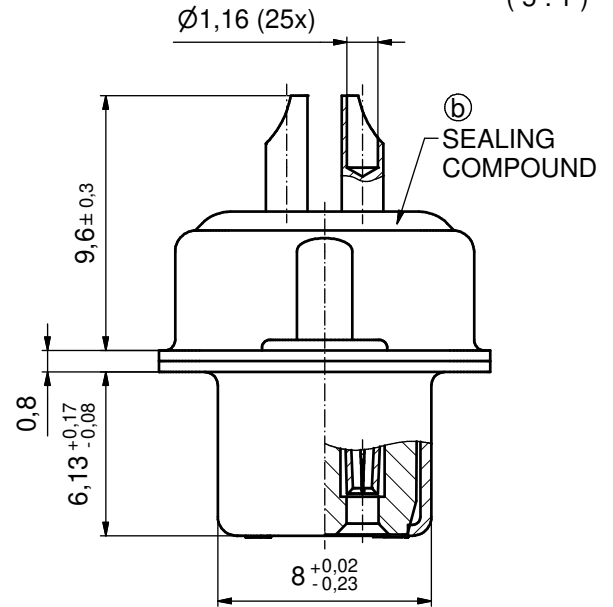
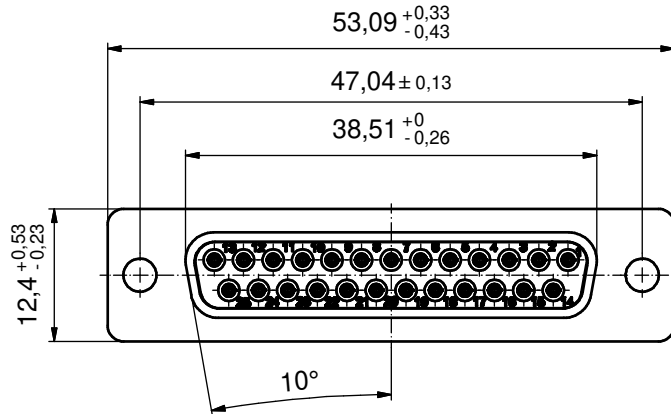

NOTES:

1. RoHS COMPLIANT
2. METALSHELLS: STEEL; min. 315µm TIN over 40-80µm NICKEL
3. INSULATOR: HIGH TEMPERATURE PLASTIC UL 94 V-0; BLACK
4. CONTACTS: COPPER ALLOY; PLATING (SEE PART-NO.):
 - PLEASE ADD A for GOLD FLASH over NICKEL (PREFERRED TYPE)
 - PLEASE ADD B for 20µm HARD GOLD over min. 50µm NICKEL
 - PLEASE ADD C for 30µm HARD GOLD over min. 50µm NICKEL
5. SEALING COMPOUND: PUR; BLUE
6. CAPACITANCE: 1300 pF ± 20%
7. DIELECTRIC WITHSTANDING VOLTAGE: 424 VDC
8. CONNECTOR IS PART MARKED: 242□26880X CONEC ABC (see note 4)

RoHS compliant

THIS DRAWING MAY NOT BE COPIED OR REPRODUCED IN ANY WAY, AND MAY NOT BE PASSED ON TO A THIRD PARTY WITHOUT WRITTEN PERMISSION. OWNERSHIP AND COPYRIGHT OF CONEC GmbH DO NOT ALTER CAD DRAWING BY HAND				tolerance		scale: 2:1 (5:1)	
				dim. in mm		material: SEE NOTES	
				date	name	title: D-SUB C-FILTER FEMALE 25pos. SOLDER CUP	
				drawn 24.05.16	Lehmenkühler		
appd. 25.05.16	Fischer	dwg no: (b) 24K1A1697		DIN-A3			
norm	DIN 41652	part no: 242□26880X (see note 4)		sh: 1			
d-old	24K1A757						
3 x b	Ä6143					24.05.2016	Lehm.
rev.	description	date	name				