



Chipsmall Limited consists of a professional team with an average of over 10 year of expertise in the distribution of electronic components. Based in Hongkong, we have already established firm and mutual-benefit business relationships with customers from,Europe,America and south Asia,supplying obsolete and hard-to-find components to meet their specific needs.

With the principle of “Quality Parts,Customers Priority,Honest Operation,and Considerate Service”,our business mainly focus on the distribution of electronic components. Line cards we deal with include Microchip,ALPS,ROHM,Xilinx,Pulse,ON,Everlight and Freescale. Main products comprise IC,Modules,Potentiometer,IC Socket,Relay,Connector.Our parts cover such applications as commercial,industrial, and automotives areas.

We are looking forward to setting up business relationship with you and hope to provide you with the best service and solution. Let us make a better world for our industry!



Contact us

Tel: +86-755-8981 8866 Fax: +86-755-8427 6832

Email & Skype: info@chipsmall.com Web: www.chipsmall.com

Address: A1208, Overseas Decoration Building, #122 Zhenhua RD., Futian, Shenzhen, China



"High Frequency Ceramic Solutions"

2.45 GHz Harmonic Filter-Balun Optimized for AT86RF230/231 and ATmega128RFA1 P/N 2450FB15L0001

Detail Specification: 11/10/2014

Page 1 of 5

General Specifications			
Part Number	2450FB15L0001	Differential Mode Attenuation (dB)	20 min.@ 4800~5000MHz 20 min.@ 7200~7500MHz
Frequency (MHz)	2400~2500	Common Mode Attenuation (dB)	20 min.@ 4800~5000MHz
Unbalanced Impedance	50 Ω		
Balanced Impedance	Impedance match to AT86RF230/231 and ATmega128RFA1	Operating Temperature	-40°C to +125°C
Insertion Loss	1.5 dB max.	Storage Conditions	+5 to +35°C, Humidity: 45-75%RH, 18 mos. Max
Return Loss	9.5 dB min.		
Phase Difference	180° ± 10	Input Power	2 Watts max. (CW)
Amplitude Difference	2.0 dB max.	Reel Quantity	4,000

* 18 months in vacuum sealed bag and 1 week after opened. For more info go to www.johansontechnology.com/silverleads

Mechanical Dimensions		
	In	mm
L	0.079 ± 0.004	2.00 ± 0.10
W	0.049 ± 0.004	1.25 ± 0.10
T	0.031 ± 0.004	0.80 ± 0.10
a	0.012 ± 0.004	0.30 ± 0.10
b	0.008 ± 0.004	0.20 ± 0.10
c	0.012 +.004/-.008	0.30 +0.1/-0.2
g	0.014 ± 0.004	0.35 ± 0.10
p	0.026 ± 0.002	0.65 ± 0.05

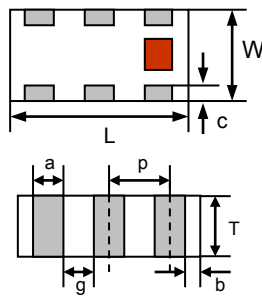

Terminal Configuration			
No.	Function	No.	Function
1	Unbalanced Port	4	Balanced Port
2	DC Feed + RF GND	5	GND
3	Balanced Port	6	GND

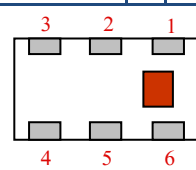

Balun Layout with AT86RF230/1

*Line width should be designed to match 50 W characteristic impedance, depending on PCB material and thickness.

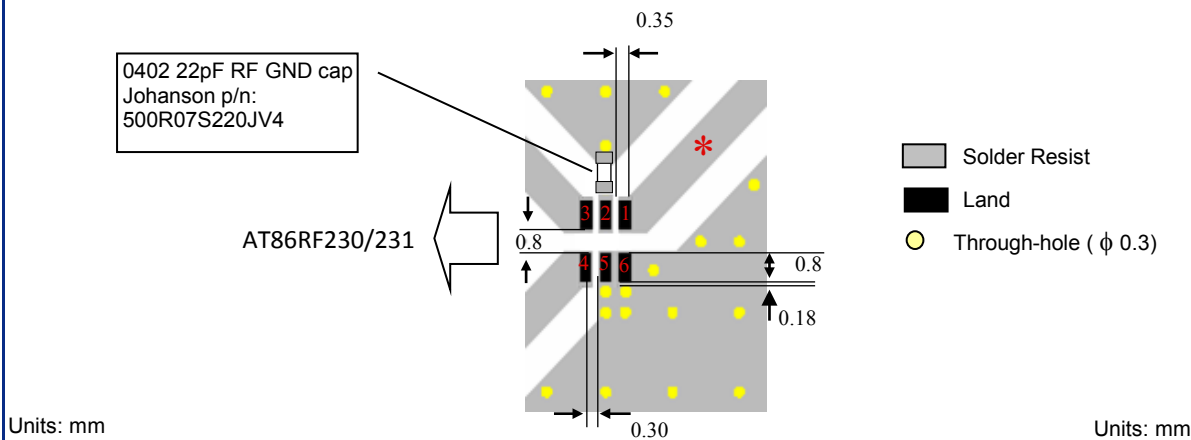

Johanson Technology, Inc. reserves the right to make design changes without notice.
All sales are subject to Johanson Technology, Inc. terms and conditions.

"High Frequency Ceramic Solutions"

2.45 GHz Harmonic Filter-Balun Optimized for AT86RF230/231 and ATmega128RFA1 P/N 2450FB15L0001

Detail Specification: 11/10/2014

Page 2 of 5

Balun Layout with ATmega128RFA1

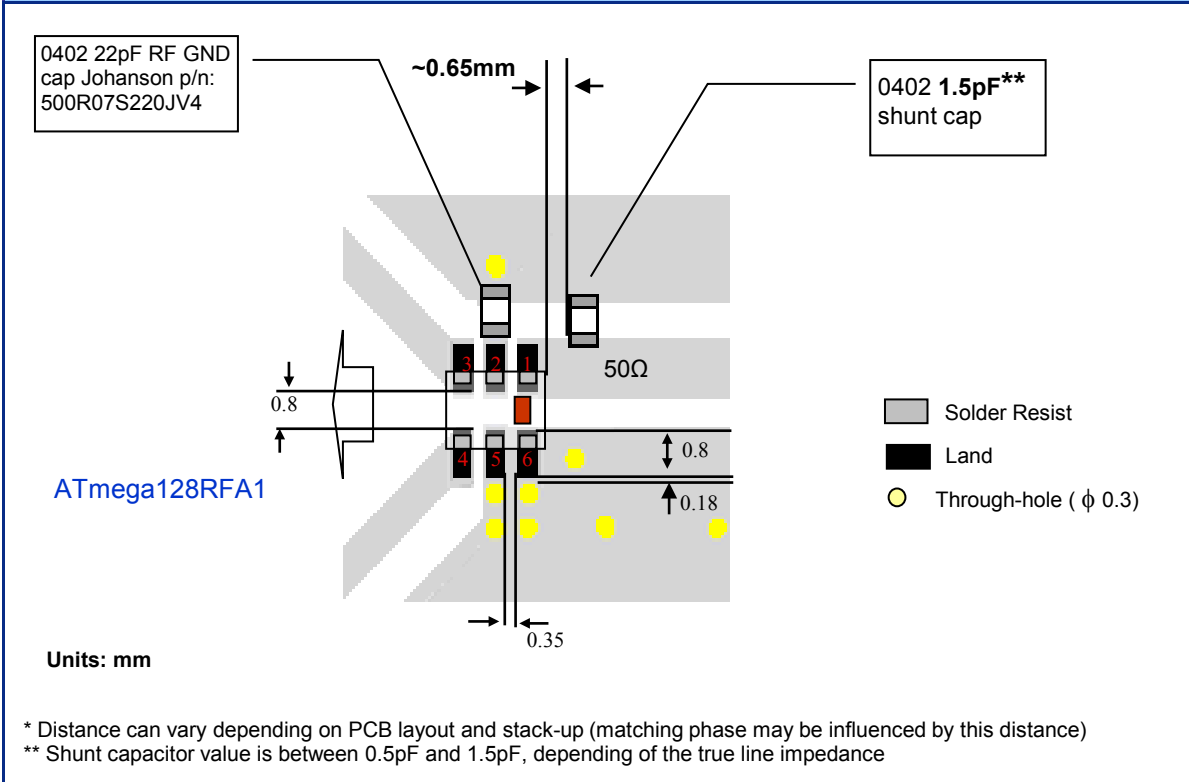

Part Numbering Scheme

P/N Suffix	Packaging Style	Bulk	Suffix = S	Eg. 2450FB15L0001S
		T & R	Suffix = E	Eg. 2450FB15L0001E
	Termination Style	AgPt	Suffix = None	Eg. 2450FB15L0001(E or S)
	Evaluation Board	2450FB15L0001-EB1SMA		

Johanson Technology, Inc. reserves the right to make design changes without notice.
 All sales are subject to Johanson Technology, Inc. terms and conditions.



www.johansontechnology.com
 4001 Calle Tecate • Camarillo, CA 93012 • TEL 805.389.1166 FAX 805.389.1821
 Ver. 7.0

2014 Johanson Technology, Inc. All Rights Reserved

"High Frequency Ceramic Solutions"

2.45 GHz Harmonic Filter-Balun Optimized for AT86RF230/231 and ATmega128RFA1 P/N 2450FB15L0001

Detail Specification: 11/10/2014

Page 3 of 5

AT86RF230/231 With DC feed graphical representation:

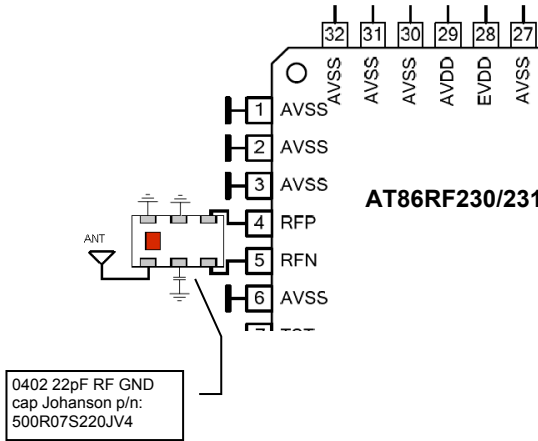

See last page for filtering performance

ATmega128RFA1 With DC feed graphical representation:

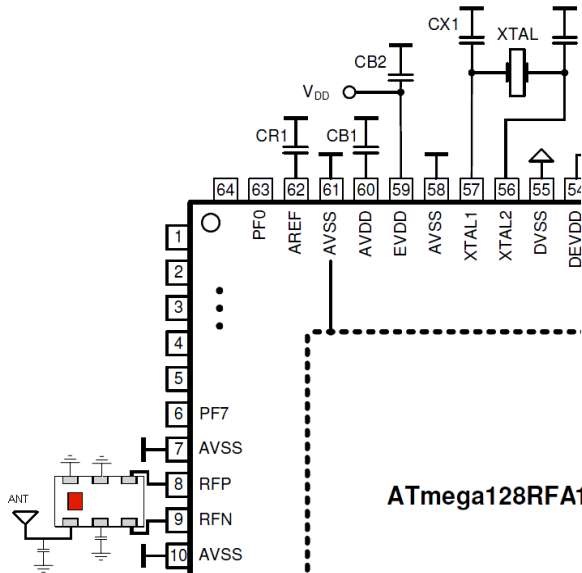

See last page for filtering performance

Johanson Technology, Inc. reserves the right to make design changes without notice.
All sales are subject to Johanson Technology, Inc. terms and conditions.

"High Frequency Ceramic Solutions"

2.45 GHz Harmonic Filter-Balun Optimized for AT86RF230/231 and ATmega128RFA1 P/N 2450FB15L0001

Detail Specification: 11/10/2014

Page 4 of 5

AT86RF230/231 With DC feed graphical representation:

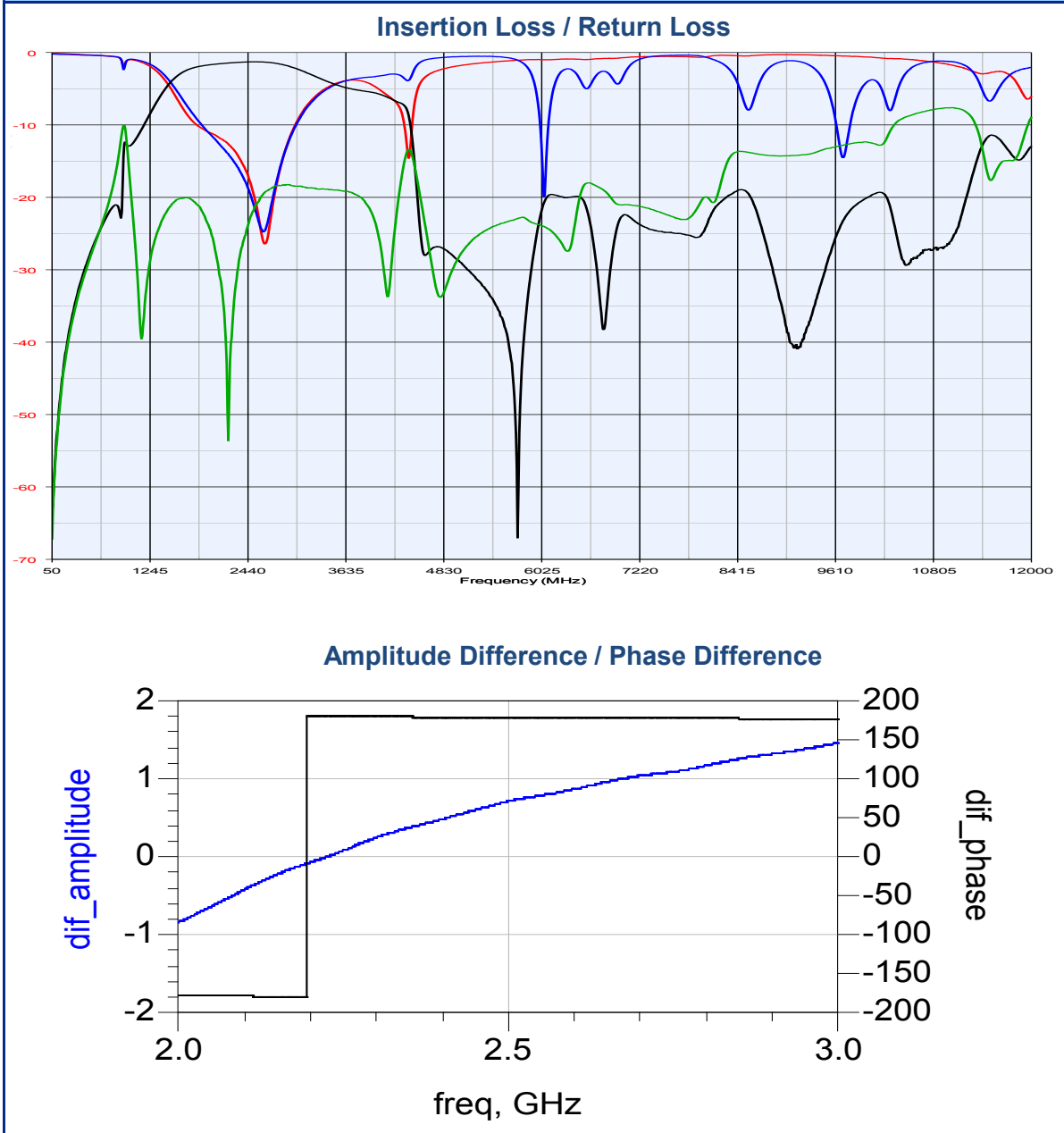

Johanson Technology, Inc. reserves the right to make design changes without notice.
All sales are subject to Johanson Technology, Inc. terms and conditions.



www.johansontechnology.com
4001 Calle Tecate • Camarillo, CA 93012 • TEL 805.389.1166 FAX 805.389.1821
Ver. 7.0

2014 Johanson Technology, Inc. All Rights Reserved

"High Frequency Ceramic Solutions"

2.45 GHz Harmonic Filter-Balun Optimized for AT86RF230/231 and ATmega128RFA1 P/N 2450FB15L0001

Detail Specification: 11/10/2014

Page 5 of 5

RoHS Compliance

www.johansontechnology.com/technical-notes/rohs-compliance.html

Packaging information

www.johansontechnology.com/ipcpackaging.html

Soldering Information

www.johansontechnology.com/ipcsoldering-profile

Antenna layout and tuning techniques

www.johansontechnology.com/tuning

Antenna layout review, tuning, and characterization services

www.johansontechnology.com/ipcantennaservices

Pad metalization information

www.johansontechnology.com/silverleads

MSL Info

www.johansontechnology.com/technical-notes/msl-rating.html

Recommended Storage Condition and Max Shelf Life

www.johansontechnology.com/ipcstorage-shelflife

Application Notes, Layout Files, and more

www.johansontechnology.com/atmel

Johanson Technology, Inc. reserves the right to make design changes without notice.
All sales are subject to Johanson Technology, Inc. terms and conditions.



Ver. 7.0

www.johansontechnology.com

4001 Calle Tecate • Camarillo, CA 93012 • TEL 805.389.1166 FAX 805.389.1821

2014 Johanson Technology, Inc. All Rights Reserved