



Chipsmall Limited consists of a professional team with an average of over 10 year of expertise in the distribution of electronic components. Based in Hongkong, we have already established firm and mutual-benefit business relationships with customers from,Europe,America and south Asia,supplying obsolete and hard-to-find components to meet their specific needs.

With the principle of "Quality Parts,Customers Priority,Honest Operation,and Considerate Service",our business mainly focus on the distribution of electronic components. Line cards we deal with include Microchip,ALPS,ROHM,Xilinx,Pulse,ON,Everlight and Freescale. Main products comprise IC,Modules,Potentiometer,IC Socket,Relay,Connector.Our parts cover such applications as commercial,industrial, and automotives areas.

We are looking forward to setting up business relationship with you and hope to provide you with the best service and solution. Let us make a better world for our industry!



Contact us

Tel: +86-755-8981 8866 Fax: +86-755-8427 6832

Email & Skype: info@chipsmall.com Web: www.chipsmall.com

Address: A1208, Overseas Decoration Building, #122 Zhenhua RD., Futian, Shenzhen, China



inspired LED

24V Flexible LED Strip Lights

Mega Bright 240Ω

Inspired LED's **24 Volt Flexible Strip Lights** are an ideal solution for large LED lighting systems. Available in custom lengths or 12M reels, these unique strips can be cut to length and terminated with solderless end connectors for easy DIY installation. Energy efficient, with a range of options for brightness and color, these 24 Volt LED Flex Strips are the perfect option for any lighting application.

Specifications:

Mega Bright 240 Ω

24V-MB240-XX

> 240 lumens/ft. 2.25 Watts/ft.

Size 2835 diodes

Product Features:

- 36 LEDs per foot, 0.33" spacing per LED
- Minimal Heat Production- No IR or UV
- Warm white (2700K) or pure white (4100K)
- Custom pre-cut lengths or full 12m reels
- Adhesive mounting to almost any flat surface
- Class 2 DC plug in connectors (3.5 x 1.3 mm) or screw terminal end-connectors available
- Dimmable with compatible systems
- Rated to last up to 100,000 hours

To be installed in accordance with NEC, using Class 2 24V power supply only



Warm White
2700K

Pure White
4100 K

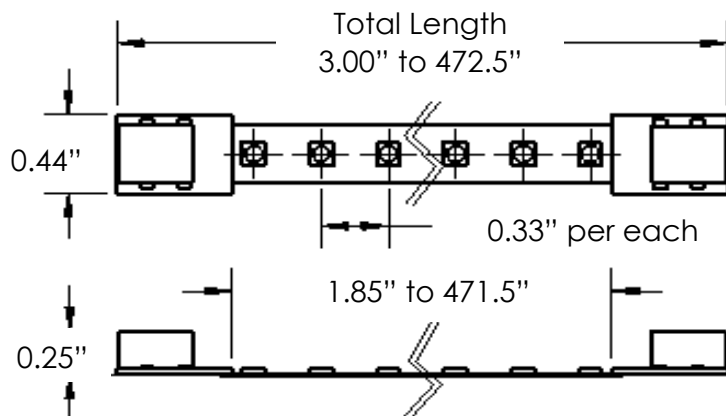

Plug-in System

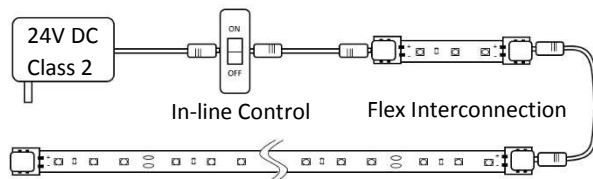

Hardwire System

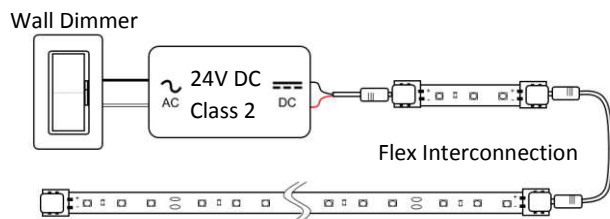

Installation Instructions:

1. Clean desired mounting surface(s) and test all products prior to installation
2. Temporarily mount LED flex strips using scotch tape
3. Interconnect LED strips with compatible DC cables
4. Run cable from LED system to control device and class 2 power source (See diagrams for more detail)
5. When satisfied with placement, peel adhesive backing from strips and press firmly to adhere LEDs in place



inspiredled.com



orders@inspiredled.com



(480) 941-4286