



Chipsmall Limited consists of a professional team with an average of over 10 year of expertise in the distribution of electronic components. Based in Hongkong, we have already established firm and mutual-benefit business relationships with customers from,Europe,America and south Asia,supplying obsolete and hard-to-find components to meet their specific needs.

With the principle of “Quality Parts,Customers Priority,Honest Operation,and Considerate Service”,our business mainly focus on the distribution of electronic components. Line cards we deal with include Microchip,ALPS,ROHM,Xilinx,Pulse,ON,Everlight and Freescale. Main products comprise IC,Modules,Potentiometer,IC Socket,Relay,Connector.Our parts cover such applications as commercial,industrial, and automotives areas.

We are looking forward to setting up business relationship with you and hope to provide you with the best service and solution. Let us make a better world for our industry!



Contact us

Tel: +86-755-8981 8866 Fax: +86-755-8427 6832

Email & Skype: info@chipsmall.com Web: www.chipsmall.com

Address: A1208, Overseas Decoration Building, #122 Zhenhua RD., Futian, Shenzhen, China



5

4

3

2

1

受控 CONTROLLED DOCUMENT

编号 P/N	25-7047-CUST	版本 Rev	01	日期 Rel'd Date	Apr29,09
-----------	--------------	-----------	----	------------------	----------

DRAWING NO.

25-7047-CUST

REVISIONS

01	OFFICIAL RELEASE				Thomas Chow
	03-10-09	Y	U	Y	U

D



Description: F W/Att. 1/2 Ring RG-6 TFE

Part No: 25-7047

Application: For Teflon/ Plenum RG-6 Cable

Crimp Tool: 24-7710 or 24-8866P

Impedance: 75 Ohms

Frequency Range: 0-750 MHz

Material: Body Brass Nickel plated

Nut Brass Nickel plated

RoHS Compliance: Yes

Technical Detail: Refer to Emerson Document P/N 25-0000

C

D

C

B

B

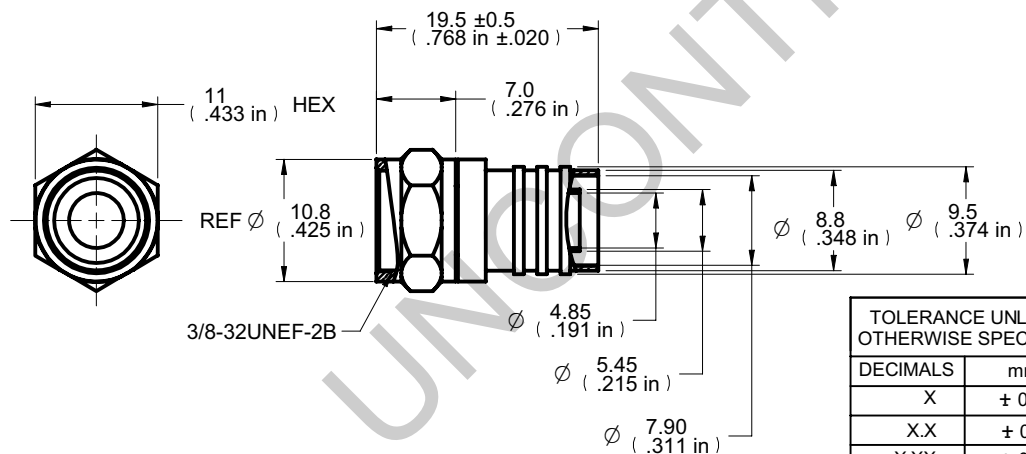

DIM OUTLINE

A

A

TOLERANCE UNLESS OTHERWISE SPECIFIED		DRAWN BY	DATE
DECIMALS	mm	BETTY.YU	03-10-09
X	± 0.5	CHECKED BY	DATE
X.X	± 0.3	BETTY.YU	03-10-09
X.XX	± 0.1	APPROVED BY	DATE
ANGLES	± 0.5°	THOMAS	03-10-09
		U/M	mm

CUSTOMER COPY

TITLE
F W/ATT. 1/2 RING RG-6 TFETHIS DRAWING WAS PRODUCED BY COMPUTER,
DO NOT SCALE DRAWING OR UPDATE MANUALLY.

SHEET	DRAWING NO.	SIZE
1 OF 1	25-7047-CUST	A

5

4

3

2

1