



Chipsmall Limited consists of a professional team with an average of over 10 year of expertise in the distribution of electronic components. Based in Hongkong, we have already established firm and mutual-benefit business relationships with customers from,Europe,America and south Asia,supplying obsolete and hard-to-find components to meet their specific needs.

With the principle of “Quality Parts,Customers Priority,Honest Operation,and Considerate Service”,our business mainly focus on the distribution of electronic components. Line cards we deal with include Microchip,ALPS,ROHM,Xilinx,Pulse,ON,Everlight and Freescale. Main products comprise IC,Modules,Potentiometer,IC Socket,Relay,Connector.Our parts cover such applications as commercial,industrial, and automotives areas.

We are looking forward to setting up business relationship with you and hope to provide you with the best service and solution. Let us make a better world for our industry!



## Contact us

Tel: +86-755-8981 8866 Fax: +86-755-8427 6832

Email & Skype: info@chipsmall.com Web: www.chipsmall.com

Address: A1208, Overseas Decoration Building, #122 Zhenhua RD., Futian, Shenzhen, China



5

4

3

2

1

DRAWING NO.  
**25-7066-CUST**

REVISIONS

01	OFFICIAL RELEASE				2009.09.0	
	08-21-09	Y	U	Y	U	TH

Description: F-56 W/P Gel Chromate 1/2 Ring  
 Part No: 25-7066  
 Application: For RG6 Cable  
 Crimp Tool: 24-7710P  
 Impedance: 75 Ohms  
 Frequency Range: 0-750 MHz  
 Material: Body Brass Chromate plated  
 Nut Brass Chromate plated  
 Gasket Rubber Nature  
 RoHS Compliance: Yes  
 Technical Detail: Refer to Emerson Document P/N 25-0000



受控 CONTROLLED DOCUMENT					
编号 P/N	25-7066-CUST	版本 Rev	01	日期 Rel'd Date	SEP 14,09

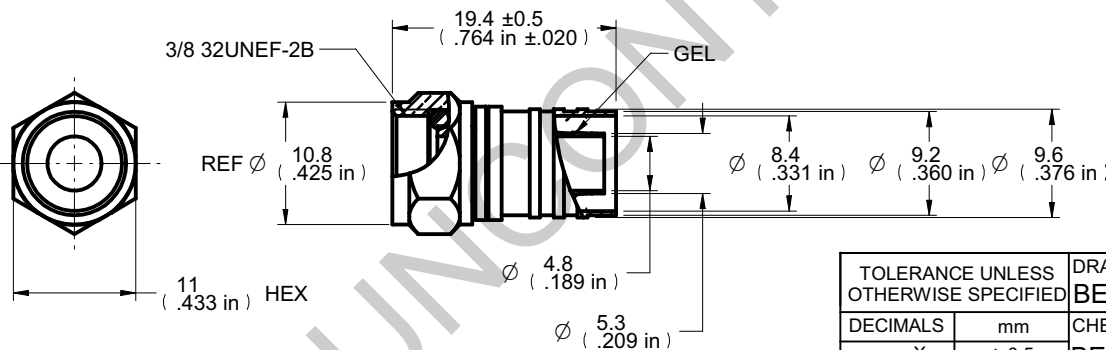

**DIM OUTLINE**

**CUSTOMER COPY**



TOLERANCE UNLESS OTHERWISE SPECIFIED		DRAWN BY	DATE
DECIMALS	mm	BETTY.YU	08-21-09
X	± 0.5	CHECKED BY	DATE
X.X	± 0.3	BETTY.YU	08-21-09
X.XX	± 0.1	APPROVED BY	DATE
ANGLES	± 0.5°	THOMAS	08-21-09
		U/M	mm

TITLE		
F-56 W/P GEL CHROMATE 1/2 RING		
SHEET	DRAWING NO.	SIZE
1 OF 1	25-7066-CUST	A

THIS DRAWING WAS PRODUCED BY COMPUTER, DO NOT SCALE DRAWING OR UPDATE MANUALLY.

5

4

3

2

1