



Chipsmall Limited consists of a professional team with an average of over 10 year of expertise in the distribution of electronic components. Based in Hongkong, we have already established firm and mutual-benefit business relationships with customers from,Europe,America and south Asia,supplying obsolete and hard-to-find components to meet their specific needs.

With the principle of “Quality Parts,Customers Priority,Honest Operation,and Considerate Service”,our business mainly focus on the distribution of electronic components. Line cards we deal with include Microchip,ALPS,ROHM,Xilinx,Pulse,ON,Everlight and Freescale. Main products comprise IC,Modules,Potentiometer,IC Socket,Relay,Connector.Our parts cover such applications as commercial,industrial, and automotives areas.

We are looking forward to setting up business relationship with you and hope to provide you with the best service and solution. Let us make a better world for our industry!



Contact us

Tel: +86-755-8981 8866 Fax: +86-755-8427 6832

Email & Skype: info@chipsmall.com Web: www.chipsmall.com

Address: A1208, Overseas Decoration Building, #122 Zhenhua RD., Futian, Shenzhen, China



5

4

3

2

1

受控 CONTROLLED DOCUMENT

编号 P/N	25-7140-CUST	版本 Rev	01	日期 Rel'd Date	Apr29,09
-----------	--------------	-----------	----	------------------	----------

DRAWING NO. 25-7140-CUST					
REVISIONS					
OFFICIAL RELEASE					
01	03-10-09	Y	U	TH	Thomas Chow



Description: F Female To Push On Male
 Part No: 25-7140
 Application: Adapter
 Crimp Tool: N/A
 Impedance: 75 Ohms
 Frequency Range: 0-750 MHz
 Material: Body Brass Nickel plated
 Contact Brass Nickel plated
 Insulator Delin
 Spring Steel Nickel plated
 RoHS Compliance: Yes
 Technical Detail: Refer to Emerson Document P/N 25-0000

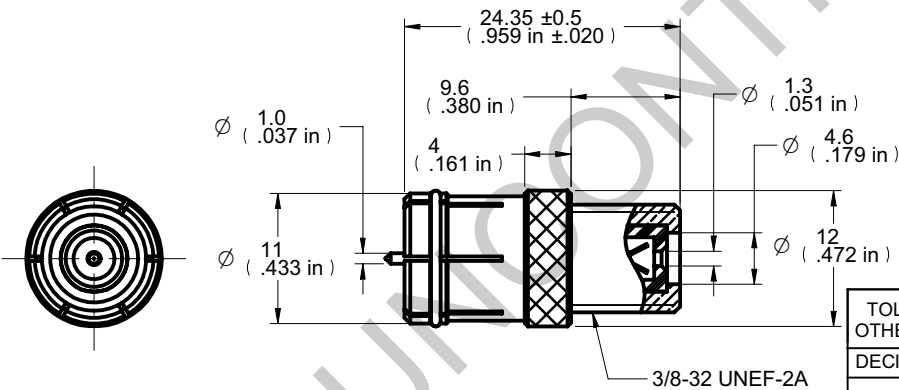

DIM OUTLINE

CUSTOMER COPY



TOLERANCE UNLESS OTHERWISE SPECIFIED		DRAWN BY	DATE
DECIMALS	mm	BETTY.YU	03-10-09
X	± 0.5	CHECKED BY	DATE
X.X	± 0.3	BETTY.YU	03-10-09
X.XX	± 0.1	APPROVED BY	DATE
ANGLES	± 0.5°	THOMAS	03-10-09
		U/M	mm

TITLE
F FEMALE TO PUSH ON MALE

THIS DRAWING WAS PRODUCED BY COMPUTER, DO NOT SCALE DRAWING OR UPDATE MANUALLY.

SHEET 1 OF 1	DRAWING NO. 25-7140-CUST	SIZE A
-----------------	------------------------------------	------------------

5

4

3

2

1