



Chipsmall Limited consists of a professional team with an average of over 10 year of expertise in the distribution of electronic components. Based in Hongkong, we have already established firm and mutual-benefit business relationships with customers from,Europe,America and south Asia,supplying obsolete and hard-to-find components to meet their specific needs.

With the principle of "Quality Parts,Customers Priority,Honest Operation,and Considerate Service",our business mainly focus on the distribution of electronic components. Line cards we deal with include Microchip,ALPS,ROHM,Xilinx,Pulse,ON,Everlight and Freescale. Main products comprise IC,Modules,Potentiometer,IC Socket,Relay,Connector.Our parts cover such applications as commercial,industrial, and automotives areas.

We are looking forward to setting up business relationship with you and hope to provide you with the best service and solution. Let us make a better world for our industry!



Contact us

Tel: +86-755-8981 8866 Fax: +86-755-8427 6832

Email & Skype: info@chipsmall.com Web: www.chipsmall.com

Address: A1208, Overseas Decoration Building, #122 Zhenhua RD., Futian, Shenzhen, China



"High Frequency Ceramic Solutions"

2.38GHz / 2.45GHz / 2.6GHz Wideband SMD Chip Antenna P/N 2500AT44M0400

Designed for: BAN, Bluetooth, 802.11, WLAN, Zigbee, Proprietary Protocol, ISM, Smart Energy, WiMax

Detail Specification: 5/24/2013

Page 1 of 9

General Specifications

Part Number	2500AT44M0400		Quantity per Reel 1,000	
Operating Frequency (MHz)	2300 - 2700			
Impedance	50 Ω			
Operating Temperature	-40 to +85°C			
Return Loss (2.3-2.7GHz)	9.5 dB min.			
Peak Gain @ 2.38GHz	2.0 dBi typ. (XZ-V)			
Average Gain @ 2.38GHz	0.0 dBi typ. (XZ-V)			
Peak Gain @ 2.45GHz	2.5 dBi typ. (XZ-V)			
Average Gain @ 2.45GHz	0.5 dBi typ. (XZ-V)			
Peak Gain @ 2.60GHz	2.0 dBi typ. (XZ-V)			Recommended Storage Conditions +5 ~ +35 °C, Humidity 45~75%RH
Average Gain @ 2.60GHz	0.0 dBi typ. (XZ-V)			

Mechanical Specifications

	In	mm
L	0.315 ± 0.008	8.00 ± 0.20
W	0.039 ± 0.008	1.00 ± 0.20
T	0.039 ± 0.008	1.00 ± 0.20
a	0.020 ± 0.008	0.50 ± 0.20
a2	0.039 ± 0.008	1.00 ± 0.20

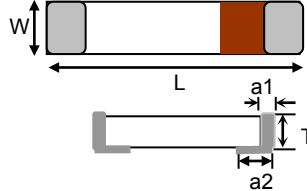

Terminal Configuration

No.	Function
1	Feeding Point
2	NC

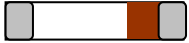

Mounting Considerations - Layout #1

Mount these devices with brown mark facing up. Units: mm

*Line width should be designed to provide 50 Ω impedance matching characteristics.

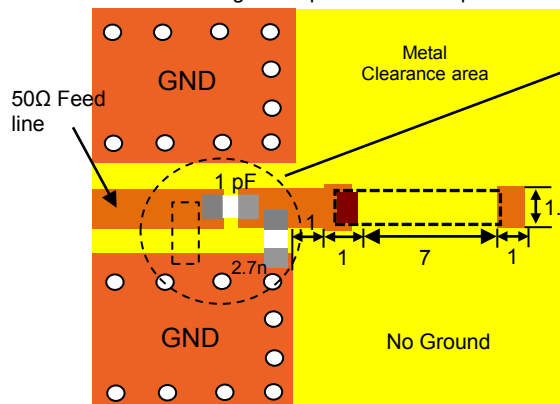

It is recommended that the designer leave available slots for a "pi" (or shunt-series-shunt) network. The antenna matching network values are used when antenna is mounted on Johanson's evaluation board. The matching values on clinet's PCB will be different. Go to: <http://johansontechnology.com/tuning> and see how to obtain the new values. If you need further help, contact our RF Applications Eng Team at: www.johansontechnology.com/en/ask-a-technical-question.html

Johanson Technology, Inc. reserves the right to make design changes without notice.

All sales are subject to Johanson Technology, Inc. terms and conditions.



www.johansontechnology.com

4001 Calle Tecate • Camarillo, CA 93012 • TEL 805.389.1166 FAX 805.389.1821

Ver 1.2

2013 Johanson Technology, Inc. All Rights Reserved

"High Frequency Ceramic Solutions"

2.38GHz / 2.45GHz / 2.6GHz Wideband SMD Chip Antenna P/N 2500AT44M0400

Designed for: BAN, Bluetooth, 802.11, WLAN, Zigbee, Proprietary Protocol, ISM, Smart Energy, WiMax

Detail Specification: 5/24/2013

Page 2 of 9

Layout #1 example (units in mm)

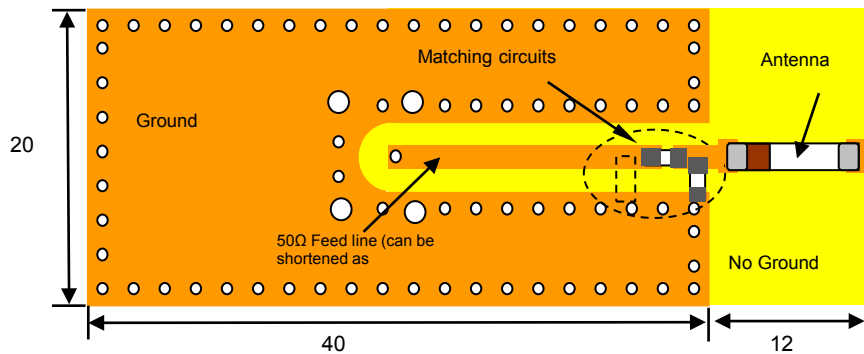

Orderable EVB p/n: 2500AT44M0400-EB1SMA

Return Loss - with Matching Circuits

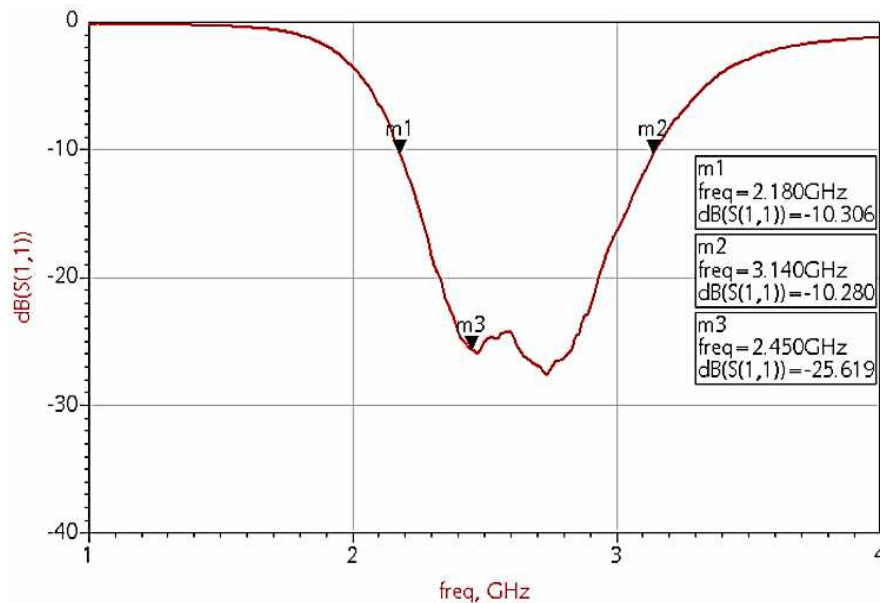

Johanson Technology, Inc. reserves the right to make design changes without notice.

All sales are subject to Johanson Technology, Inc. terms and conditions.



www.johansontechnology.com
4001 Calle Tecate • Camarillo, CA 93012 • TEL 805.389.1166 FAX 805.389.1821

Ver 1.2

2013 Johanson Technology, Inc. All Rights Reserved

"High Frequency Ceramic Solutions"

2.38GHz / 2.45GHz / 2.6GHz Wideband SMD Chip Antenna

P/N 2500AT44M0400

Designed for: BAN, Bluetooth, 802.11, WLAN, Zigbee, Proprietary Protocol, ISM, Smart Energy, WiMax

Detail Specification: 5/24/2013

Page 3 of 9

Typical Radiation Patterns @ 2.38GHz - Layout #1

Typical Radiation Patterns - Layout #1

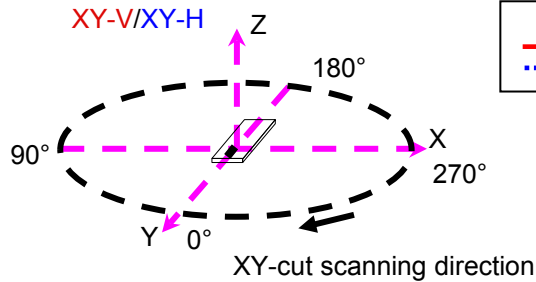

XY cut @2.38GHz
— Vertical
⋯ Horizontal

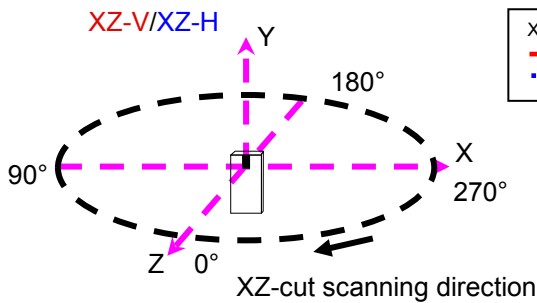
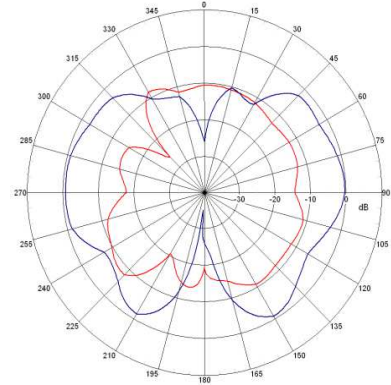

XZ cut @2.38GHz
— Vertical
⋯ Horizontal

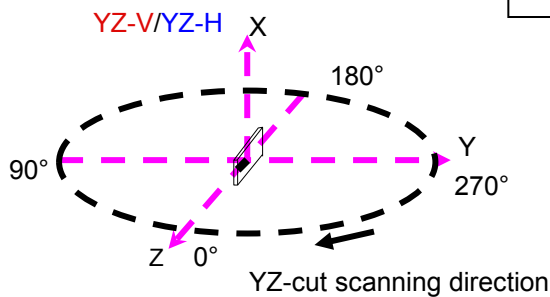
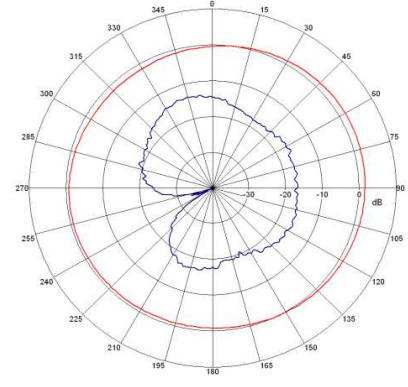

YZ cut @2.38GHz
— Vertical
⋯ Horizontal

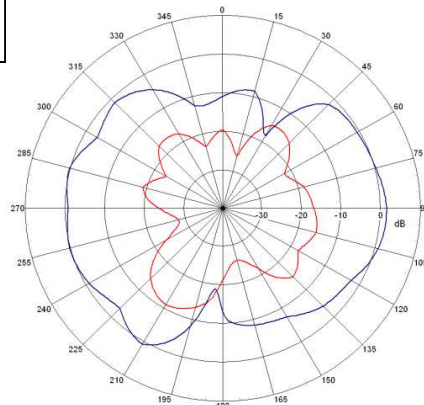

Johanson Technology, Inc. reserves the right to make design changes without notice.

All sales are subject to Johanson Technology, Inc. terms and conditions.



www.johansontechnology.com

4001 Calle Tecate • Camarillo, CA 93012 • TEL 805.389.1166 FAX 805.389.1821

Ver 1.2

2013 Johanson Technology, Inc. All Rights Reserved

"High Frequency Ceramic Solutions"

2.38GHz / 2.45GHz / 2.6GHz Wideband SMD Chip Antenna

P/N 2500AT44M0400

Designed for: BAN, Bluetooth, 802.11, WLAN, Zigbee, Proprietary Protocol, ISM, Smart Energy, WiMax

Detail Specification: 5/24/2013

Page 4 of 9

Typical Radiation Patterns @ 2.45GHz - Layout #1

Typical Radiation Patterns - Layout #1

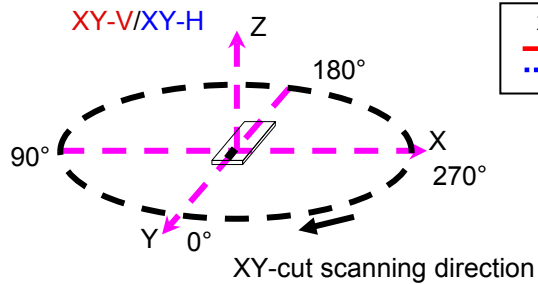

XY cut @2.45GHz
— Vertical
- - - Horizontal

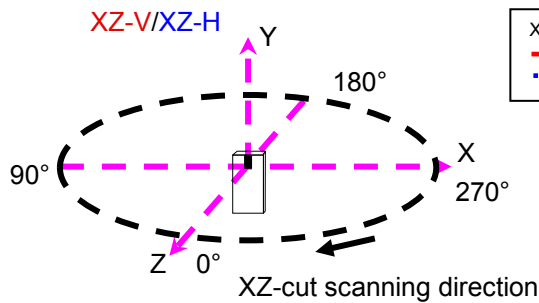
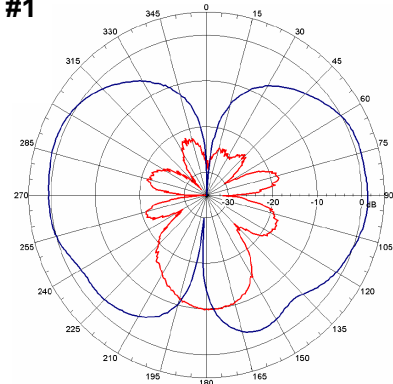

XZ cut @2.45GHz
— Vertical
- - - Horizontal

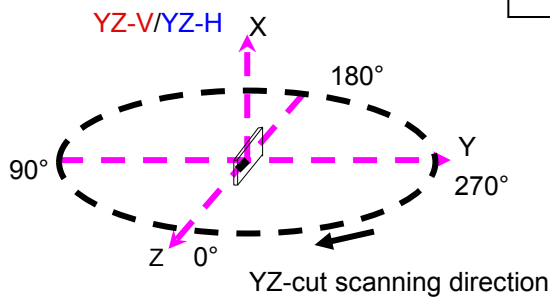
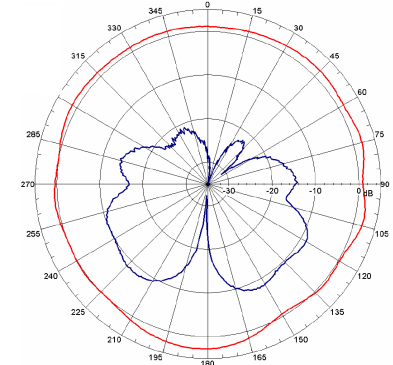

YZ cut @2.45GHz
— Vertical
- - - Horizontal

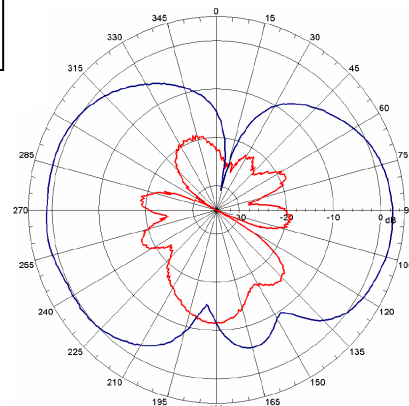

Johanson Technology, Inc. reserves the right to make design changes without notice.

All sales are subject to Johanson Technology, Inc. terms and conditions.



www.johansontechnology.com

4001 Calle Tecate • Camarillo, CA 93012 • TEL 805.389.1166 FAX 805.389.1821

Ver 1.2

2013 Johanson Technology, Inc. All Rights Reserved

"High Frequency Ceramic Solutions"

2.38GHz / 2.45GHz / 2.6GHz Wideband SMD Chip Antenna

P/N 2500AT44M0400

Designed for: BAN, Bluetooth, 802.11, WLAN, Zigbee, Proprietary Protocol, ISM, Smart Energy, WiMax

Detail Specification: 5/24/2013

Page 5 of 9

Typical Radiation Patterns @ 2.6GHz - Layout #1

Typical Radiation Patterns - Layout #1

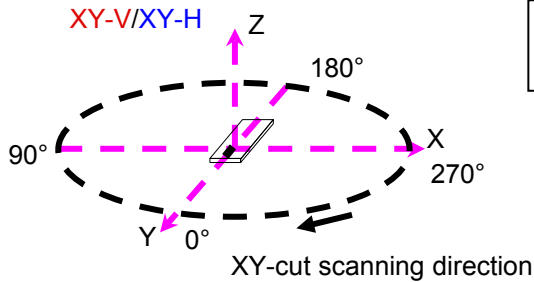

XY cut @2.6GHz
 — Vertical
 Horizontal

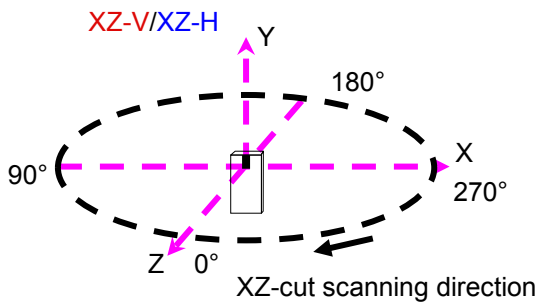
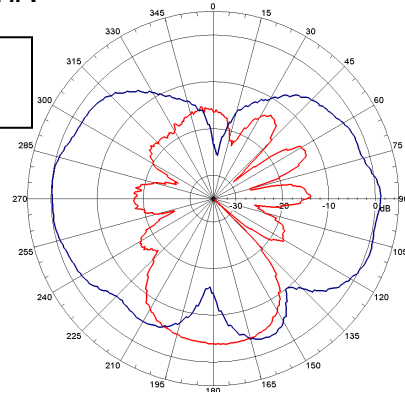

XZ cut @2.6GHz
 — Vertical
 Horizontal

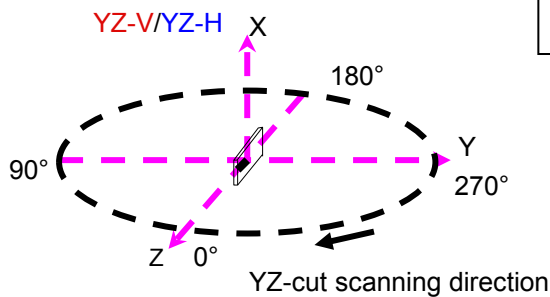
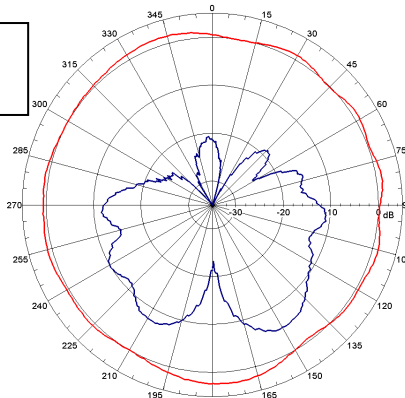

YZ cut @2.6GHz
 — Vertical
 Horizontal

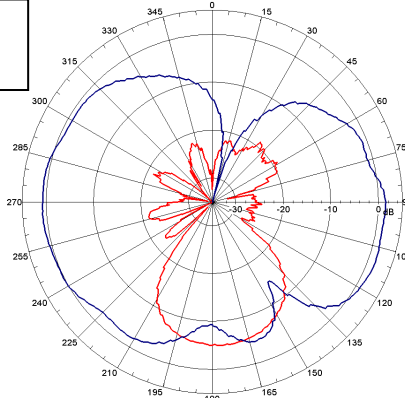

Johanson Technology, Inc. reserves the right to make design changes without notice.

All sales are subject to Johanson Technology, Inc. terms and conditions.



www.johansontechnology.com
 4001 Calle Tecate • Camarillo, CA 93012 • TEL 805.389.1166 FAX 805.389.1821

Ver 1.2

2013 Johanson Technology, Inc. All Rights Reserved

"High Frequency Ceramic Solutions"

2.38GHz / 2.45GHz / 2.6GHz Wideband SMD Chip Antenna

P/N 2500AT44M0400

Designed for: BAN, Bluetooth, 802.11, WLAN, Zigbee, Proprietary Protocol, ISM, Smart Energy, WiMax

Detail Specification: 5/24/2013

Page 6 of 9

Alternate layout - Layout #2

Mount these devices with brown mark facing up. Units: mm

*Line width should be designed to provide 50 Ω impedance matching characteristics.

Layout #2 example (units in mm)**

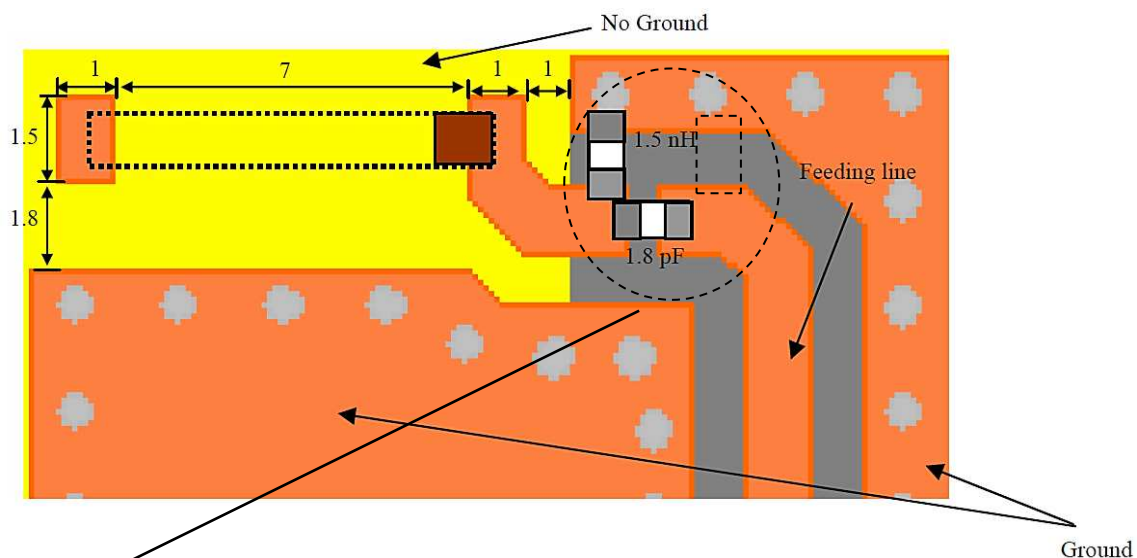

It is recommended that the designer leave available slots for a "pi" (or shunt-series-shunt) network. The antenna matching network values are used when antenna is mounted on Johanson's evaluation board. The matching values on clinet's PCB will be different.

Go to: <http://johansontechnology.com/tuning> and see how to obtain the new values.

If you need further help, contact our RF Applications Eng Team at:

www.johansontechnology.com/en/ask-a-technical-question.html

**Bandwidth is about 190MHz in this configuration

Johanson Technology, Inc. reserves the right to make design changes without notice.

All sales are subject to Johanson Technology, Inc. terms and conditions.



www.johansontechnology.com
4001 Calle Tecate • Camarillo, CA 93012 • TEL 805.389.1166 FAX 805.389.1821

Ver 1.2

2013 Johanson Technology, Inc. All Rights Reserved

"High Frequency Ceramic Solutions"

2.38GHz / 2.45GHz / 2.6GHz Wideband SMD Chip Antenna P/N 2500AT44M0400

Designed for: BAN, Bluetooth, 802.11, WLAN, Zigbee, Proprietary Protocol, ISM, Smart Energy, WiMax

Detail Specification: 5/24/2013

Page 7 of 9

Typical Electrical Characteristics (T=25 °C)

Test Board - Layout #2 (units in mm)

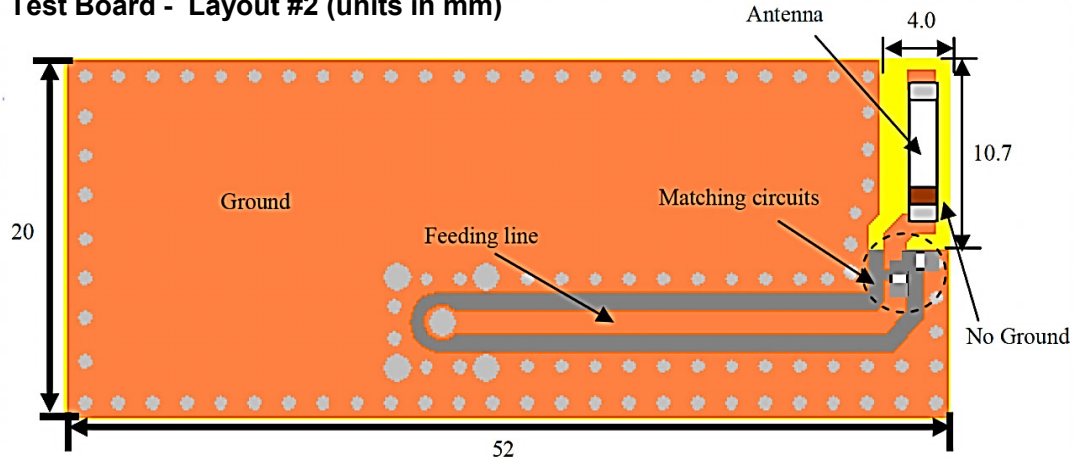

Return Loss - with Matching Circuits

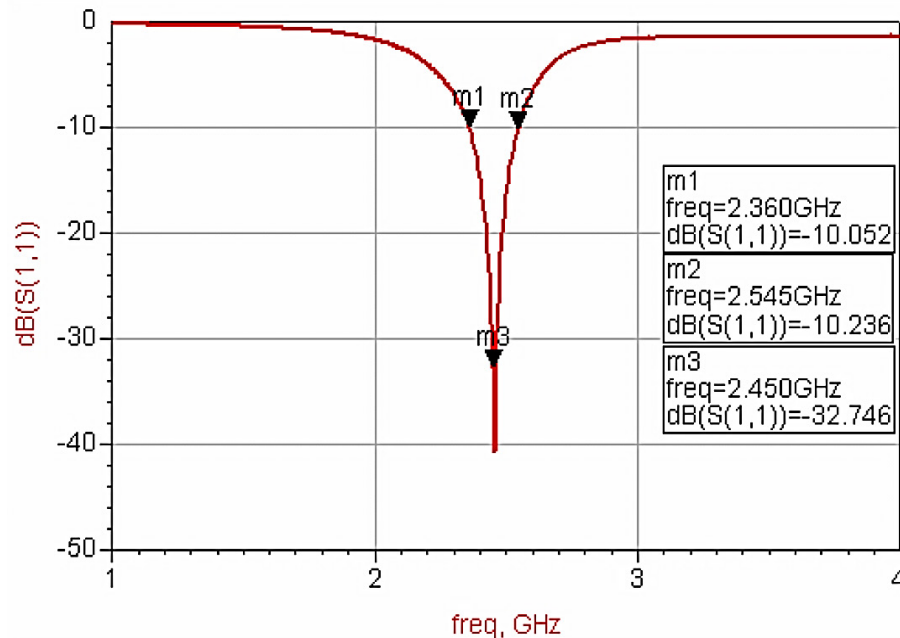

Johanson Technology, Inc. reserves the right to make design changes without notice.

All sales are subject to Johanson Technology, Inc. terms and conditions.



www.johansontechnology.com

4001 Calle Tecate • Camarillo, CA 93012 • TEL 805.389.1166 FAX 805.389.1821

Ver 1.2

2013 Johanson Technology, Inc. All Rights Reserved

"High Frequency Ceramic Solutions"

2.38GHz / 2.45GHz / 2.6GHz Wideband SMD Chip Antenna

P/N 2500AT44M0400

Designed for: BAN, Bluetooth, 802.11, WLAN, Zigbee, Proprietary Protocol, ISM, Smart Energy, WiMax

Detail Specification: 5/24/2013

Page 8 of 9

Typical Radiation Patterns @ 2.45GHz - Layout #2

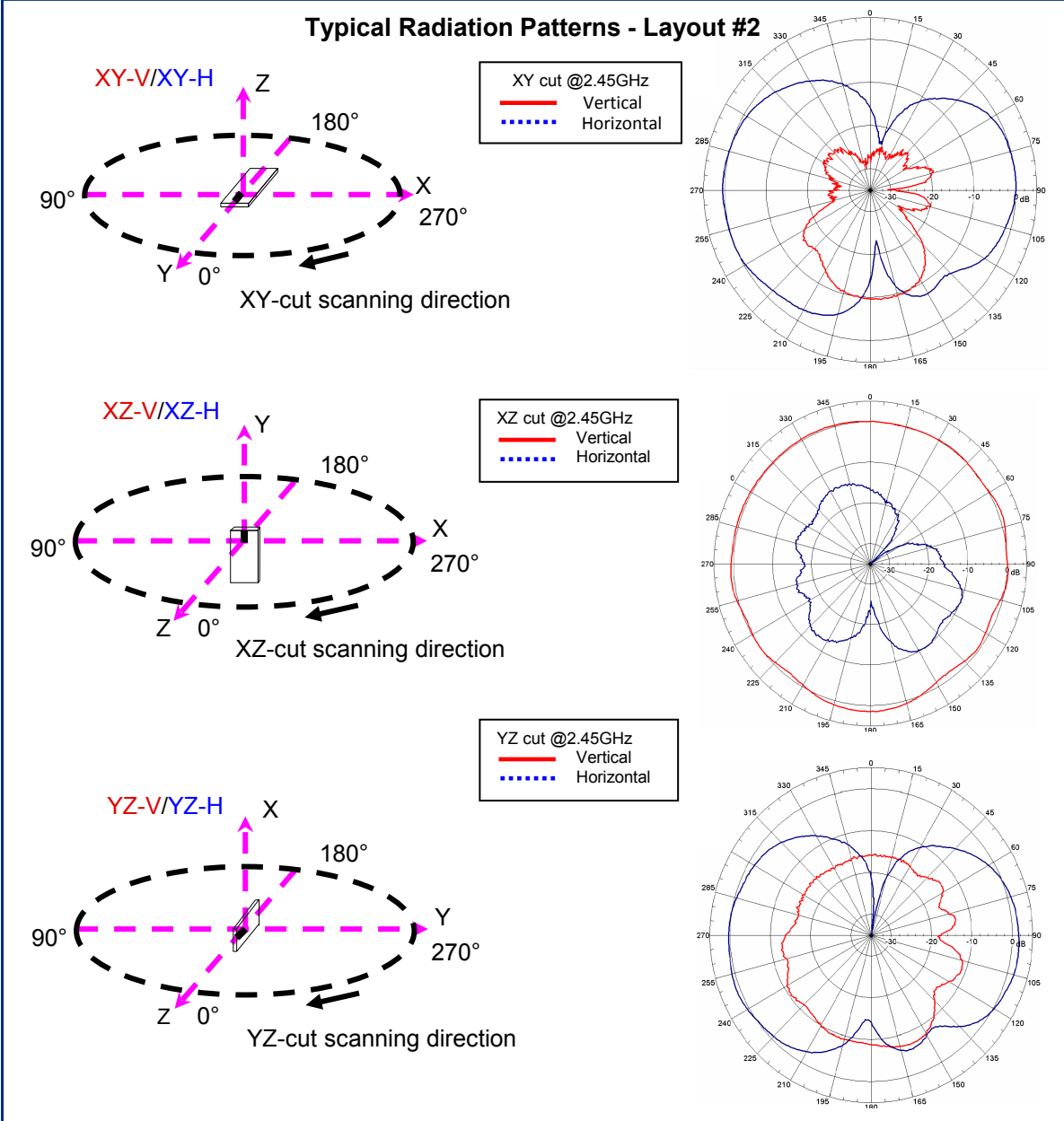

Johanson Technology, Inc. reserves the right to make design changes without notice.

All sales are subject to Johanson Technology, Inc. terms and conditions.



www.johansontechnology.com
 4001 Calle Tecate • Camarillo, CA 93012 • TEL 805.389.1166 FAX 805.389.1821

Ver 1.2

2013 Johanson Technology, Inc. All Rights Reserved

"High Frequency Ceramic Solutions"

2.38GHz / 2.45GHz / 2.6GHz Wideband SMD Chip Antenna P/N 2500AT44M0400

Designed for: BAN, Bluetooth, 802.11, WLAN, Zigbee, Proprietary Protocol, ISM, Smart Energy, WiMax

Detail Specification: 5/24/2013

Page 9 of 9

Additional Info

Part Number Explanation

P/N Suffix	Packing Style			
	Bulk	Suffix = S	eg. 2500AT44M0400S	
	T & R	Suffix = T	eg. 2500AT44M0400E	
	Evaluation Board	SMA	Suffix = -EB1SMA	eg. 2500AT44M0400-EB1SMA

Tape & Reel Specifications

<http://www.johansontechnology.com/ipcpackaging.html>

Soldering Profile

<http://johansontechnology.com/ipcsoldering-profile>

Johanson Technology, Inc. reserves the right to make design changes without notice.

All sales are subject to Johanson Technology, Inc. terms and conditions.



www.johansontechnology.com

4001 Calle Tecate • Camarillo, CA 93012 • TEL 805.389.1166 FAX 805.389.1821

Ver 1.2

2013 Johanson Technology, Inc. All Rights Reserved